

FAX-B820/B822/B840

Service Manual

First Edition

HY8-10B0-000

COPYRIGHT 2004 CANON INC. FAX-B820/B840 082003 XX 0.00-0

Scope

This manual has been issued by Canon Inc., to provide the service technicians of this product with the information necessary for qualified persons to learn technical theory, installation, maintenance, and repair of products. The manual covers information applicable in all regions where the product is sold. For this reason, it may contain information that is not applicable to your region.

Revision

This manual could include technical inaccuracies or typographical errors due to improvements or changes made to the product. When changes are made to the contents of the manual, Canon will release technical information when necessary. When substantial changes are made to the contents of the manual, Canon will issue a revised edition.

The following do not apply if they do not conform to the laws and regulations of the region where the manual or product is used

Trademarks

Product and brand names appearing in this manual are registered trademarks or trademarks of the respective holders.

Copyright

All right reserved. No part of this manual may be reproduced in any form or by any means or translated into another language without the written permission of Canon Inc., except in the case of internal business use.

Copyright 2004 by Canon Inc.
CANON INC.

5-1 Hakusan 7-Chome, Toride-city, Ibaraki 302-8501, Japan

I. MANUAL OUTLINE

This manual is divided into three parts, and contains information required for servicing the product.

Part 1: Maintenance

Information on maintenance and troubleshooting of the product.

Part 2: Technical Reference

New technology and technical information of the product.

Part 3: Appendix

Schematic and Specifications.

Reference

This manual does not provide sufficient information of disassembly and reassembly procedures. Refer to the graphics in the separate Parts Catalog.

II. Table of Contents

Page	Part 1: Maintenance
1 - 1	1. Maintenance
1 - 1	1.1 Adjustment, Periodic Replacement Parts, Periodic Maintenance, Replacement of Consumables by Service Engineer
1 - 1	1.2 Customer Maintenance
1 - 2	1.3 Product Life
1 - 2	1.4 Special Tools
1 - 2	2. LIST OF ERROR DISPLAY
1 - 2	2.1 Troubleshooting Index
1 - 3	2.2 Errors shown on display (judgment criterion: check display)
1 - 5	2.3 Errors not shown on display
1 - 8	3. Repair
1 - 8	3.1 Caution when replacing service parts
1 - 20	3.2 Service Switches
1 - 28	3.3 Explanation of service data
1 - 36	3.4 Test Function
Page	Part 2: Technical Reference
2 - 1	1. New Technology
Page	Part 3: Appendix
3 - 1	1. Schematic
3 - 2	2. Specifications

Part 1

Maintenance

1.MAINTENANCE

1.1 Adjustment, Period Replacement Parts, Periodic Maintenance, and Replacement Consumables by Service Engineer

Resetting the ink counter

(1) Adjustment

Item	When	Purpose	Tool	When
Adjusting gear phase	When replacing gear unit	To adjust gear phase		
Resetting the ink counter	When replacing NK ABSORBER	To reset the ink counter		
CS pre-scan	When replacing CS	To set scan data		
Data Set	When replacing SCNT board When replacing CR	To initialize data and restore factory setting		

(2) Periodic maintenance

Item	When	Purpose	Tool	When
None				

(3) Periodic replacement parts

Item	When	Purpose	Tool	When
None				

(4) Replacement consumables

Item	When	Purpose	Tool	When
None				

1.2 Customer Maintenance

Adjustment	Timing	Purpose	Tool	Approx. time
Print head cleaning	When print quality is not satisfying.	To improve nozzle conditions.		
BJ FAX Cartridge replacement	When an BJ FAX Cartridge becomes empty.			
Paper feed roller	When paper does not feed properly.	To clean the paper feed rollers.		

1.3 Product Life

(1) Printer

The value from (I) - (III), whichever comes first.

(I)18,000 pages of printing

(II)18,000 pages of scanning

(III)5 years of use

(2) Print CRG (ink tank)

Approx. 900 pages of printing

*When printing Canon Fax Standard Chart No.1

1.4 Special Tools

Name	Tool No.	Purpose	Remarks
None			

2. LIST OF ERROR DISPLAY

2.1 Troubleshooting Index

Use the troubleshooting index below to investigate the cause of the problem and refer to the specified page for countermeasures.

[Problem]

2.1.1 Errors shown on display (judgment criterion: check display)

When errors shown on display	Refer to 1-3 page
When errors not shown on display	Refer to 1-5 page

2.1.2 Errors not shown on display (judgment criterion: check machine)

General errors	Refer to 1- 5 page
	No power
	Abnormal display
	Operation panel buttons do not work
	No sound from speaker
	Printing failure (judgment criterion: test print failure)

Paper not properly fed	Refer to 1-6 page
	Paper not picket up from ASF

Printing operation abnormality	Refer to 1-6 page
	Nothing is printed
	Carriage motor does not move

Print quality defect	Refer to 1-6 page
	Print is not clear
	Blurred image or smudged print
	Stain on the back of printout
	Inconsistent print quality
	Head cleaning required
	Horizontal white streaks in black header
Scanning failure (judgment criterion: test print is OK but copy fails)	

Scanning failure	Refer to 1-7 page
	Document slips on the rollers
	Document is not properly separated
	Scanning assembly sensor broken

Abnormality in scanned image	Refer to 1-7 page
	Nothing printed
	Vertical streaks in image

2.2 Errors shown on display (judgment criterion: check display)

2.2.1 User error messages

Check the error message in question and take the appropriate action.

[BUSY/NO SIGNAL] (#018)

Cause: Other party machine does not respond within 55 seconds. (T0 timeout)

Countermeasure: Contact the other party and have them check the condition of their fax.

Transmit manually. In the case of an international call,
insert a pause into the programmed telephone number.

Cause: The machine's tone/ pulse dial settings are not correct.

Countermeasure: Programme the settings according to the telephone line being used.

Cause: Other party machine is not a G3 fax.

Countermeasure: Contact the other party and have them send or receive in G3.

Cause: Other party machine is broken.

Countermeasure: Contact the other party and have them check the condition of their fax machine.

Cause: Dialed number is busy.

Countermeasure: Call again later.

[CARTRIDGE JAMMED]

Printer position correction failure

Cause: Carriage does not operate normally, for one of the following reasons.

Carriage shaft is broken/ deformed. Broken /deformed parts

Or, contact sensor unit does not return from scanning position.

Countermeasure: Replace printer assembly or contact sensor unit.

[CHECK DOCUMENT] (#001)

Cause: PAPER JAM

This message appears when the document edge sensor cannot detect the edge of the document after the document sensor detects the presence of the document and the feeder roller rotates 360 degrees to perform one document feeding operation

Countermeasure: Clear the document jam.

[CHECK PAPER SIZE]

Cause: The size of paper set in the ASF is different from the paper size programmed in the printer.

Countermeasure: Change the printer's PAPER SIZE setting to the correct paper size.

[CHECK PRINTER] (##332 to ##337, #343, ##345, ##346, ##348)

Cause: Printer internal failure

Countermeasure: (1) Is the BJ cartridge's operation being hampered by jammed paper? Clear the jammed paper.

(2) Press the STOP button.

(3) Reset the BJ cartridge.

(4) Turn the power OFF/ ON.

(5) Refer to the appropriate action for the error code.

[DATA ERROR]

Cause: SRAM data have been destroyed and a checksum error has been generated because the lithium battery is dead or some kind of SRAM failure.

Countermeasure: (1) Perform ALL CLEAR in the service mode.

(2) Replace the SCNT board.

[DOC. TOO LONG] (#003)

Cause: The document length exceeds 700cm.

Countermeasure: Make a reduced size copy of the document and send it again.

[MEMORY FULL] (#037)

Cause: A very large document has been received in memory reception and the memory is full.

Countermeasure: (1) Print out the document(s) stored in the memory and try the operation again.

(2) Delete any unnecessary documents from the memory.

Cause: There are too many pages in the transmission document and the transmission memory is full.

Countermeasure: Split up the document and send it.

2.2.2 Error codes

a) Service error code output

When service data #1 SSSW SW01 bit 0 is set to '1', if a transmission ends in error,

a service error code will be output on the transmission activity report, reception results report and the error transmission report. Also, in the event of an error, the error code will be shown on the display.

b) Error codes

Refer to 'G3/G4 Facsimile Error Codes Service Handbook' for details on error code causes and countermeasures.

2.3 Errors not shown on display

2.3.1 General errors

·No power

- (1) Check that the power cord is properly connected.
- (2) Check the connection between the SCNT board (J151) and the power supply unit.
- (3) Check the power supply unit fuse (F1).
- (4) Replace the power supply unit.
- (5) Replace the SCNT board.

·Abnormal display

Nothing displayed

- (1) Check the connection between the control panel unit and the SCNT board (J202).
- (2) Replace the control panel unit.
- (3) Replace the SCNT board.

Part of the LCD does not display

- (1) Check the connection between the control panel unit and the SCNT board (J202).
- (2) Replace the control panel unit.
- (3) Replace the SCNT board

· Operation panel buttons do not work

- (1) If test mode can be used, check which buttons do not work.
- (2) Check the connection between the control panel unit and the SCNT board (J202).
- (3) Replace the control panel unit.
- (4) Replace the SCNT board.

· No sound from speaker

- (1) Check the connection between the speaker and the SCNT board (J152).
- (2) Replace the speaker.
- (3) Replace the SCNT board.

2.3.2 Printing failure

Printing failure (ajudgement criterion: copy failure)

· Paper not properly fed (ajudgement criteria: check machine)

Paper feed motor is not working.

- (1) Check the connection between the paper feed motor and the SCNT board (J302).
- (2) Replace the paper feed motor.
- (3) Replace the SCNT board.

Paper not picked up from the ASF

- (1) Check for any abnormalities in the paper feed motor drive switching mechanism.
- (2) Check that the ASF assembly drive gear has been properly attached.
- (3) Replace the pickup roller unit.
- (4) Replace the SCNT board (paper edge sensor or pickup roller sensor failure).

· Printing operation abnormality

Nothing is printed (blank page)

- (1) Take out the BJ cartridge and install it again.
- (2) Clean the BJ cartridge five times.
- (3) Replace the BJ cartridge.
- (4) Check the connection between the carriage ribbon cable and the SCNT board (J251).
- (5) Replace the SCNT board.

Carriage motor does not move

- (1) Check the connection between the carriage motor and the SCNT board (J301).
- (2) Replace the carriage motor.
- (3) Replace the SCNT board.

·Print quality defect

·Printing quality unstable

If the printed image has white streaks or spots, head cleaning should be performed.

When the following sequence is performed, the BJ cartridge head will be cleaned automatically.

Press the Function button, cleaning button and then the START/ COPY button.

Head cleaning required

The print head nozzles sometimes become clogged with paper dust or ink, etc.

In such cases, head cleaning should be performed.

When the following sequence is performed, the BJ cartridge head will be cleaned automatically.

Press the Function button, cleaning button and then the START/ COPY button.

·Horizontal white streaks in black header

- (1) Clean the BJ FAX cartridge five times. Perform a visual check to see whether ink is being properly ejected.
- (2) Remove the BJ FAX cartridge and then replace it.
- (3) Replace the BJ FAX cartridge.
- (4) Check the connection between the carriage ribbon cable and the SCNT board (J251).
- (5) Replace the SCNT board.

2.3.3 Scanning failure

· Scanning failure (judgement criterion: reception is OK but copy fails)

Document slips on the rollers (evaluation level: visual check. Copy image elongated.)

- (1) Clean the document feed rollers.
- (2) Replace the rollers.

Document is not properly separated (evaluation level: check on actual machine.)

- (1) Check that the paper feed motor is driving all rollers. (Check for any broken gears or foreign bodies.)
- (2) Clean the document feed rollers and the document separation rollers.
- (3) Replace the ASF unit.

Scanning assembly sensor broken (judgement criterion: document is not detected when set or when being fed.)

- (1) Perform a copy operation and check for any faulty sensors.
- (2) Check the connections between the sensors and the SCNT board.
- (3) Replace the SCNT board.

· Abnormality in scanned image (evaluation level: Check copy image for defects.)

Nothing printed

- (1) Check the connection between the contact sensor and the SCNT board (J201).
- (2) Clean the white reference.
- (3) Replace the contact sensor.
- (4) Replace the SCNT board.

Vertical streaks in image

- (1) Clean the contact sensor's scanning glass.
- (2) Clean the white reference.
- (3) Check the connection between the contact sensor and the SCNT board (J201).
- (4) Replace the contact sensor.

3. Repair

3.1 Caution when replacing service parts

3-1-1 Safety Cautions

Electrical shock

Be sure to disconnect the power cable and modular cable to prevent electrical shock.

If working with power on is required, do not use grounding strap. Using such equipment may create conducting pathway, posing a risk of electrical shock.

See the following for parts and components that may generate electrical shock:

- Power supply unit primary (supplied with AC voltage)
- Telephone line primary

High temperature

In order to prevent burns during disassembly, allow at least ten minutes, after the power has been switched off, for the high temperature components to cool down.

General high temperature components are as follows.

- Motors
- Power supply unit
- Elements on driver ICs, etc., on PCBs (in particular, ICs with heatsinks)
- BJ cartridge aluminum plate

Fire

It is dangerous to throw lithium batteries and parts and components containing flammable substances, such as cartridges, etc., into fire.

Such parts and components must be disposed of in accordance with local laws and regulations.

Ignition

When using solvents such as alcohol, etc., while conducting service, there is a danger of fire igniting from heat from internal circuitry and from sparks.

Before using any such solvents, be sure to switch off the power and allow time for high temperature parts to cool down. Make sure that there is sufficient ventilation when working with solvents.

Movable parts

In order to prevent accidents with movable parts, be sure to remove the power cable when conducting service that requires disassembly. Also, take care that personal accessories and hair, etc., are not caught in any moving parts.

3.1.2 General Cautions

Damage due to electrostatic discharge

This machine contains contact sensors and printed circuit boards that use ROMs, RAMs, custom chips and other electronic components that are vulnerable to damage by electrostatic discharge.

Be careful to avoid any damage from electrostatic discharge when conducting service that requires disassembly.

*Static electricity warning

Electrostatic discharge can destroy electronic components and alter electrical characteristics.

Plastic tools and even your hands, if they are not earthed, contain sufficient static electricity to damage electronic components.

The following materials may be used as countermeasures against electrostatic discharge:

- Earth-connected conductive mat,
- Earth-connected wrist-strap,
- Crocodile clips for the purpose of grounding metallic parts of the main unit.

For service conducted on the user's premises, etc., where such countermeasure materials are not available, the following countermeasures may be employed.

- Use anti-static bags for the storage and carrying of PCBs and electrical elements.
- Avoid silk and polyester clothing and leather-soled shoes, favoring instead cotton clothes and rubber soled shoes.
- Avoid working in a carpeted area.
- Before work, touch the grounded earth terminals of the main unit in order to discharge any static electricity.
- Use a wrist-strap and earth the metal parts of the main unit.
- PCBs and electrical elements must be lifted by holding the edges and avoid direct contact with terminals.

*Caution against electrical shock while working with power on

In cases where service must be carried out with power on, via a connected power cable, be sure to wear an anti-static wrist-strap or other earth, in order to prevent an electrical path being created through your body.

Attaching and removing cables

Attaching and removing cables with the power still on may cause breakdowns and should be avoided.

In particular, flat cables are likely to cause short circuits. When attaching or removing cables, always be sure to turn the power off.

3.1.3 Prevention of ink soiling

Be careful when handling the BJ ink cartridge nozzle, head cap, head wiper and waste ink pad. Residual ink may soil the main unit, working surfaces, your hands and clothes, etc.

The ink is water-soluble, but because it contains pigments, it will not wash out of clothes.

The ink does not contain any substances that are harmful to humans, but does contain organic solvents (isopropyl alcohol 67-63-0, glycerin 56-81-5 and ethylene glycol 107-21-1).

If the ink should accidentally get into someone's eyes, rinse the affected eye with plenty of clean water and seek medical attention.

If a large quantity of ink is accidentally swallowed, seek medical advice immediately.

In such a case, let the doctor know exactly what is written on the BJ cartridge label.

Conductivity of the ink

The ink used in the BJ cartridge is conductive. This means that, if the ink leaks, mechanical parts should be wiped with a dampened paper towel or similar and electrical circuits wiped with tissue paper so that all ink is removed from below the IC chips.

If power is switched on while ink is leaking on the electrical circuits, the circuitry may short out and be damaged.

If ink is leaking, the power must be switched off.

3.1.4 Action in the Event of Abnormality (All Clear)

In the event of extreme noise or shock, etc., in very rare cases, the display may go out, and all the buttons become inoperable. In that case, perform an All Clear. This operation returns all values and settings to their default settings.

[16:50 FaxTal] Standby State (Time and RX Mode displayed on LCD)

1. Select User Data Mode: Press the function button.

[DATA REGISTRATION]

2. Select Service Data Mode: Press the [#] button.

[#1 SSSW]

3. Press [←] [→] until [#8 CLEAR] appears.

[#8 CLEAR]

4. Press the [Start/Copy] button.

Press [←] [→] to select ALL.

*ALL will initialize all data.

[ALL]

5. Press the [Start/Copy] button.

[PRESS SET BUTTON]

6. Press the [Start/Copy] button.

[CLEAR OK]

7. Standby State

[PLEASE WAIT]

8. Standby State

[DISPLAY LANGUAGE]

9. Press the [Start/Copy] button.

Press [←] [→] to select the language and then press the [Start/Copy] button.

[DATA ENTRY OK]

[COUNTRY SELECT]

10. Press the [Start/Copy] button.

Press [←] [→] to select the country and then press the [Start/Copy] button.

[DATA ENTRY OK]

Figure 1-1 How to Perform ALL CLEAR

3.1.5 PRODUCT TRANSPORTATION

Please follow procedures below when to transport repaired products.

- (1) Be sure to attach the BJ cartridge to a carriage unit.
- (2) Turn off the printer, and secure the carriage locks in the home position.

* If the print head is removed from the printer and left alone by itself, ink is likely to dry.

For that reason, keep the print head installed in the printer even during transportation.

Then, securely lock the carriage in the home position, to prevent the carriage from moving and applying stress to the carriage, during transportation.

3.1.6 Caution about Data

Data to be deleted when the machine is turned OFF.

The following data will be deleted when the blackout happens or when the power cord is unplugged from the outlet.

FAX Image Data

*Audio data is stored in the flash memory, and therefore will not be deleted by turning OFF the machine.

Data to be Held in the Memory

The machine will back up all data stored in the control memory to SRAM memory in the case of blackout and unplugged power cord.

3.1.7

(a) Caution about Detaching the Cradle from the Main Unit



PHOTO 1-1

Insert an opener (1) to detach claw from the main unit and remove the cradle from the main unit.

(b) Caution about Detaching the Printer Unit from the Main Unit

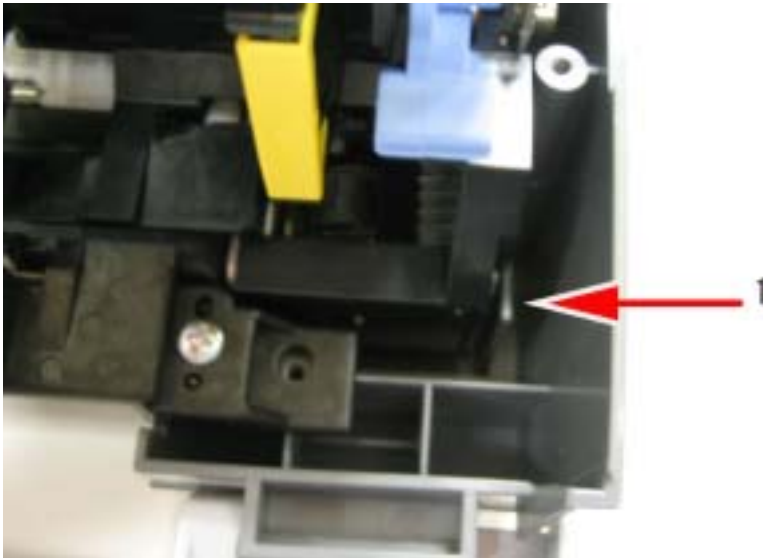

PHOTO 1-2

Detach claw (1) on the right edge of the printer unit from the main unit.



PHOTO 1-3

Detach claw (2) from the main unit by lifting the right edge of the printer unit and moving it to the right.

(c) Caution about Detaching the Operation Unit from the Main Unit

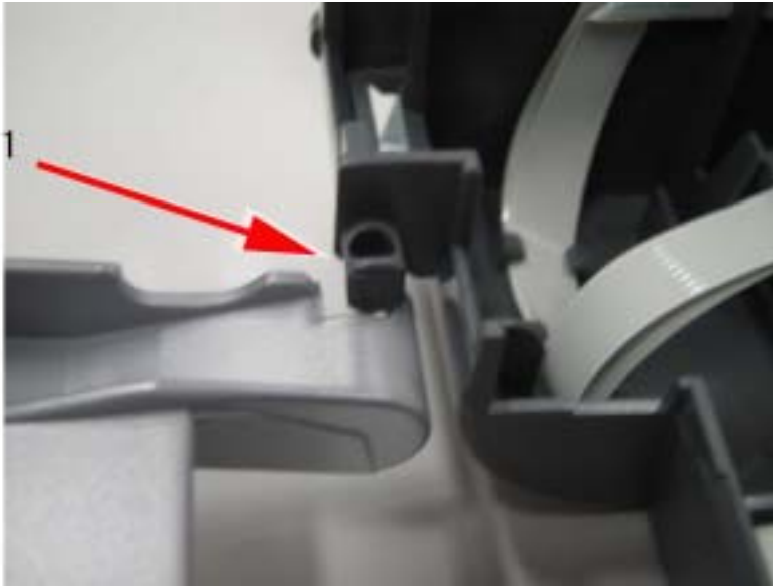

PHOTO 1-4

Push down the Operation Unit by engaging the cut (1)

3.1.8 Caution about Replacing SCNT Board

[1] Caution about the Jumper Switch when Replacing or Repairing SCNT Board

Backing up data stored in the control memory is activated by lithium battery with the jumper switch (JP51) mounted on SCNT board being shorted out. If the power goes off with JP51 being open, data stored in the control memory is deleted. If it is necessary to have JP51 open, be sure to check data in the control memory and in the audio memory or output such data beforehand. Please note that JP51, which is mounted on SCNT board (a service part), has a jumper plug inserted halfway (open) when stocked. (This is to prevent battery drain when stocked as service part.) Therefore, it is necessary to insert a jumper plug thoroughly to have JP51 being shorted out when replacing a mounted SCNT board with SCNT board stocked as service part.

(*1) Caution about Image/Audio Data

Data stored in the image memory is deleted when the machine is turned OFF. Audio data is not deleted when the machine is turned OFF as it is stored in the flash memory. Management information of image/audio data is stored in SRAM and is backed up by lithium battery.

(*2) Caution about Undertaking Repair

When taking users' machines for repairmen, data registered in the machine may be deleted during the course of repair. So be sure to ask users to check registered data (user data of one-touch speed dialing) or to output such data before repair. However, data may not be checked if LCD is damaged or the printer is damaged.

(*3) Caution about Returning Repaired Machine to Users

If ALL CLEAR is executed or SCNT board is replaced, registered data is deleted. Be sure to let users know that registered data has been deleted due to repair.

[2] Please see the following instruction to reset the waste ink counter, to initialize the ink sensor and to perform prescanning whenever SCNT Board is replaced.

1. Press the buttons in the order of [FUNCTION]- [*] - [5].
2. [TIME SET HH:MM] is displayed.
3. Current time is displayed following the date [12/12/12 xx.xx].
4. Press the [START/COPY] button.
5. [DATA SET] is displayed.
6. [CS PRESCAN] is displayed.
7. [INK DETECTOR] is displayed.
8. [PRESS START/COPY] is displayed.
9. Press the [START/COPY] button.
10. [# TST START:STBY] is displayed.
11. Press the [START/COPY] button.
12. [Please Wait] is displayed.
13. The machine enters the standby mode.
14. Press the [FUNCTION] button and then [#] button to enter the service mode. Execute [All Clear].
15. [Please Wait] is displayed.
16. The machine enters the standby mode.
17. [LANGUAGE] is displayed.
18. Press the [START/COPY] button.
19. Select the language.
20. Press the [START/COPY] button.
21. [DATA ENTRY OK] is displayed.
22. [COUNTRY SELECT] is displayed.
22. Press the [START/COPY] button.
24. Select the country.
(If country of your choice does not appear, turn the machine OFF and then ON. Press the [FUNCTION] button and then [#] button to enter the service mode. Select the country from the [Type Setting].)
25. Press the [START/COPY] button.
26. [DATA ENTRY OK] is displayed.
27. The machine enters the standby mode.
28. Press the [FUNCTION] button to set the date and time.
29. Make a photocopy to check the operation.

END

* If Waste Ink Absorber is not replaced along with SCNT board, please refer to [SET LOST CNT] in the procedures to reset Waste Ink Counter and type an appropriate number from 0 to 99 (%).

3.1.9 Caution about Replacing the Gear Unit

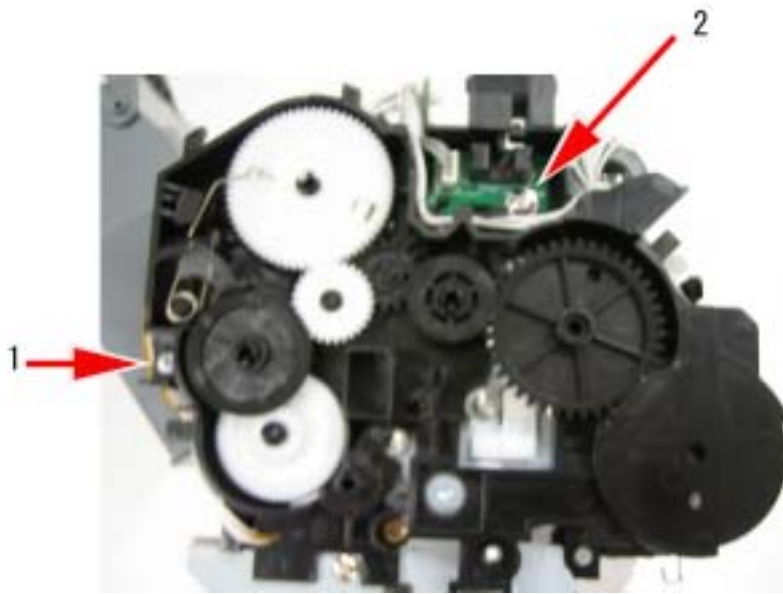

PHOTO 1-5

Remove screw (1) and (2).

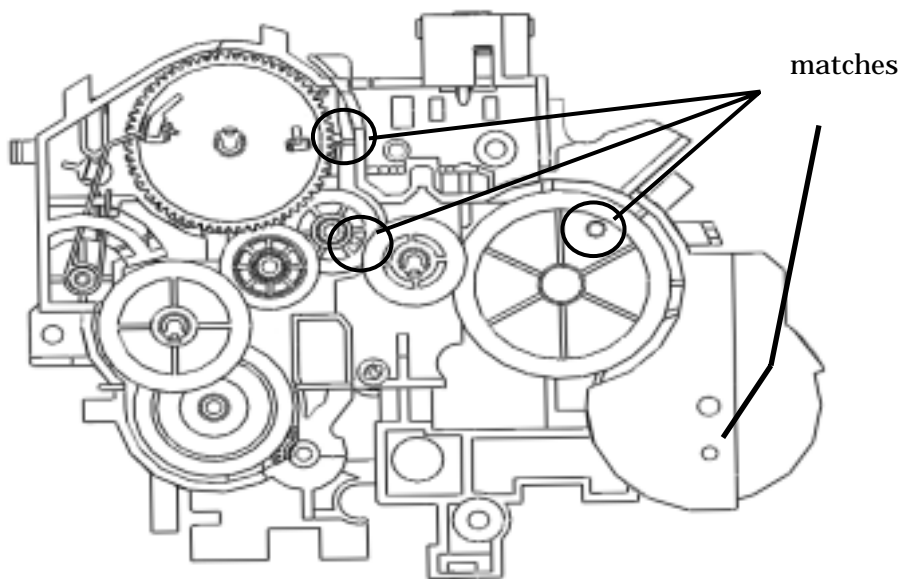

Figure 1-2

When attaching the gear unit, check that phase of each gear matches.

3.1.10 Caution about Replacing CS

[1] When detaching CS from the main unit:

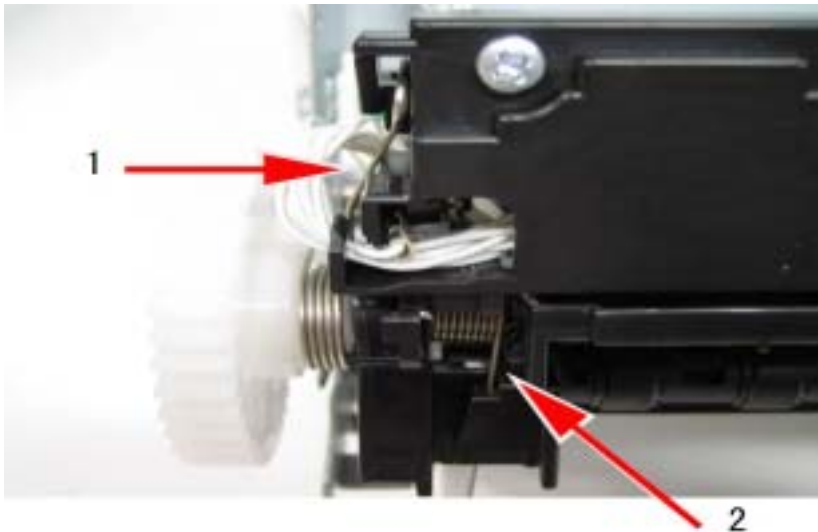

PHOTO 1-6

Unhook spring (1) and (2) and detach CS from the main unit.

[2] When attaching CS to the main unit:

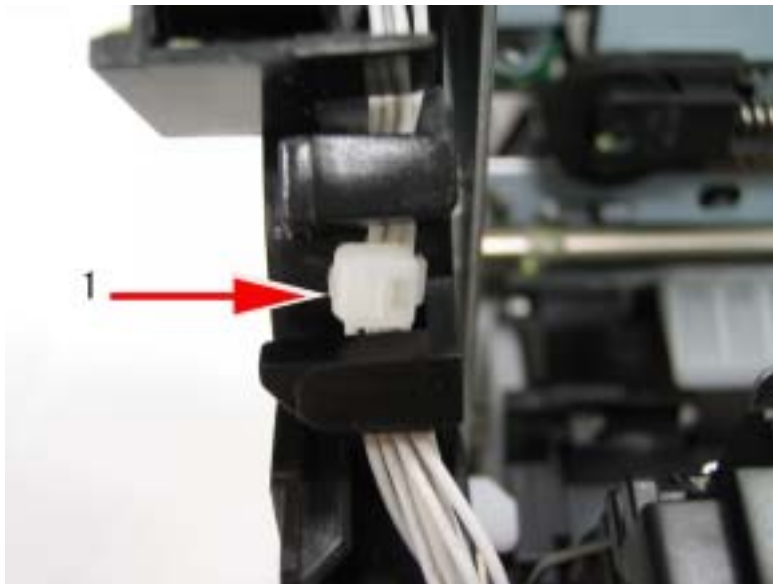

PHOTO 1-7

Set a strap tying CS cables to the position indicated by an arrow so that mobility of the CS unit will not be affected.

[3] Follow the procedures below to conduct CS test after replacing CS in the service mode.

[16:50 FaxTel] Standby (date and Receive mode display)

1. User data mode selection: Press the Function button.

[DATA REGISTRATION]

2. Service data mode selection: Press the [#] button.

[#1 SSSW]

3. Menu item selection: Select [TEST MODE] by pressing the [←] [→] button.

Press the Start/Copy button.

[TEST MODES [1]-[8]]

4. Select [7].

CS TEST [1] – [4]

3.1.11 Caution about Replacing ASF Unit

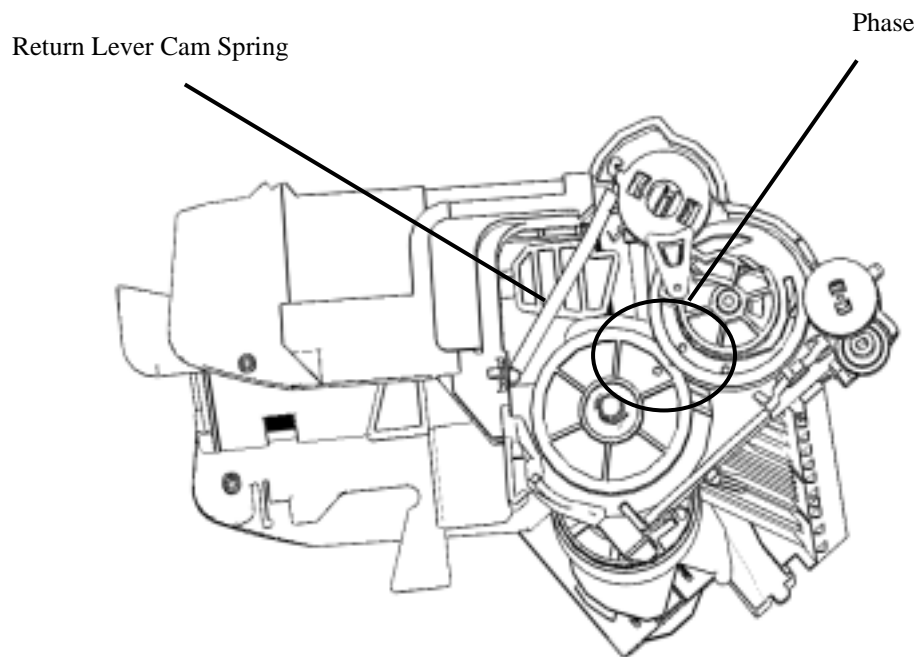

Figure 1-3

1. Check that the return lever cam spring is hooked on a claw.
2. Rotate the control gear in the direction of the arrow and check that phase of the control gear and the roller gear match.

3.1.12 Caution about Replacing Waste Ink Absorber

Please perform the following procedure to reset Waste Ink Counter whenever Waste Ink Absorber is replaced.

1. Enter the Service Mode, and then select [TEST MODE].
2. Press the [Start] button.
3. [TEST MODE [1]-[8]] is displayed.
4. Press [#] button.
5. [AMI MODE [1]-[*9]] is displayed.
6. Press [7] button.
7. [FACULTY [1]-[6]] is displayed.
8. Press [6] button.
9. [LOST INK CHECK] is displayed.
10. Press the [Start] button.
11. [LOST INK CHECK [1]-[2]] is displayed.
12. Press [2] button.
13. [SET LOST CNT] is displayed.
14. Press the [Start/Copy] button. [LOST INK=0] is displayed on LCD. Press the numeric button to reset the waste ink counter.
15. Press the [Start/Copy] button to have [TEST MODE [1]-[8]] displayed on LCD again.

3.2 SERVICE SWITCHES

3.2.1 Hardware switches

This machine does not have any hardware switches for service.

3.2.2 Service data settings

Service data can be checked and changed according to the displayed menu items. For details of the SSSW/ parameters and default values in this machine, refer to 3-2-5 Service data settings. Details of the SSSW and parameters can be found in 'G3 Facsimile Service Data Handbook (Rev.0)'.

3.2.3 Service data overview

The service data menu items are divided into the following nine blocks.

#1 SSSW (Service Soft Switch settings)

These setting items are for basic fax service functions such as error management, echo countermeasures, and communication trouble countermeasures.

#2 MENU (MENU switch settings)

These setting items are for functions required during installation, such as NL equalizer and transmission levels.

#3 NUMERIC Param. (NUMERIC parameter settings)

These setting items are for inputting numeric parameters such as the various conditions for the FAX/TEL switching function.

#4 NCU (NCU settings)

These setting items are for telephone network control functions such as the selection signal transmission conditions and the detection conditions, for the control signals sent from the exchange.

#5 TYPE (TYPE setting)

The type setting makes the service data conform to a specific country communications standards. There is only one setting item in this block.

#6 GENESIS (UHQ function setting)

These setting items are for scanned image processing such as edge enhancement and error diffusion processing.

#7 PRINTER (PRINTER function settings)

Not in use

#8 CLEAR (data initialization mode)

Data of selected items are initialized.

#9 ROM (ROM management)

Displays the ROM version number

3.2.4 Service Data Setting Method

Please follow the procedures below to set/register service data.

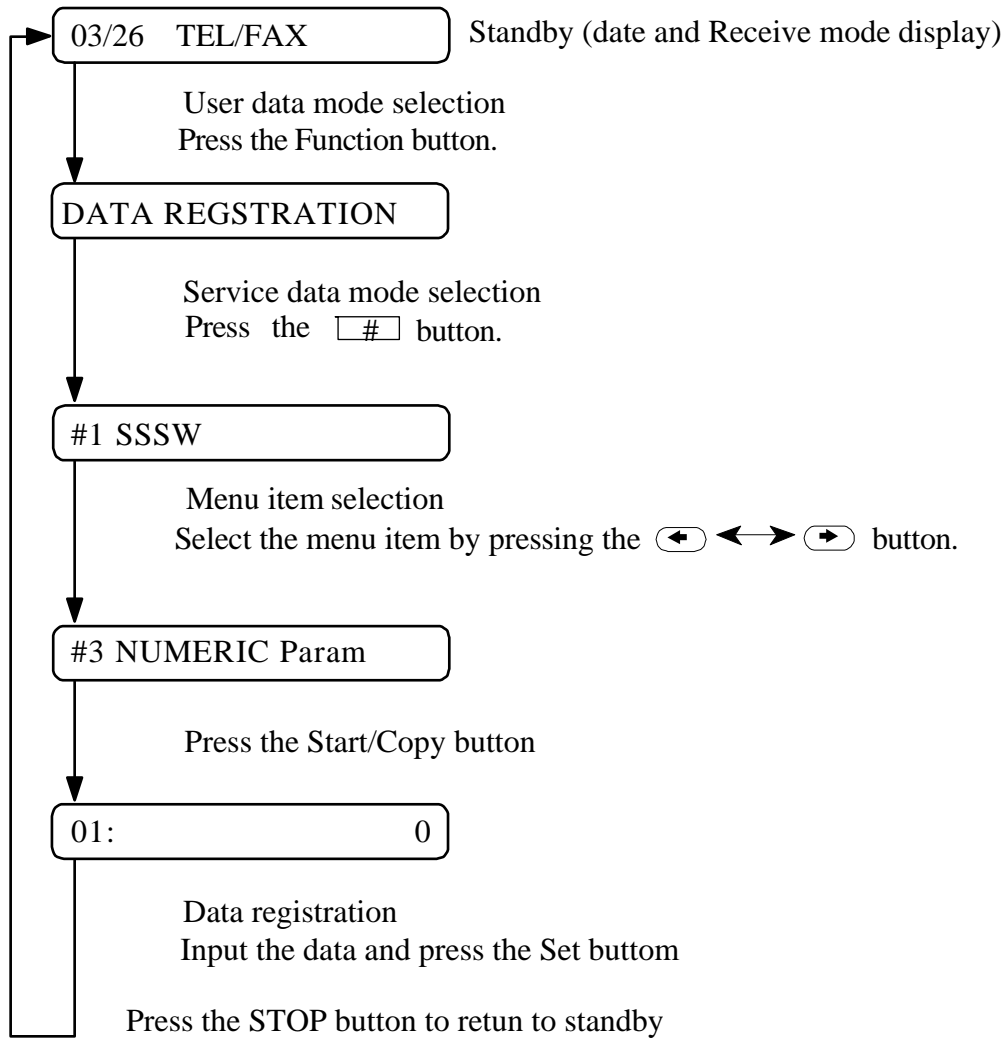

Figure 1-4 Service Data Registration/Setting

*Precautions when registering/setting service data

We cannot guarantee the integrity of any reception of transmission operations during the registration process. Detach the telephone line before registering service data.

3.2.5 Service Menu

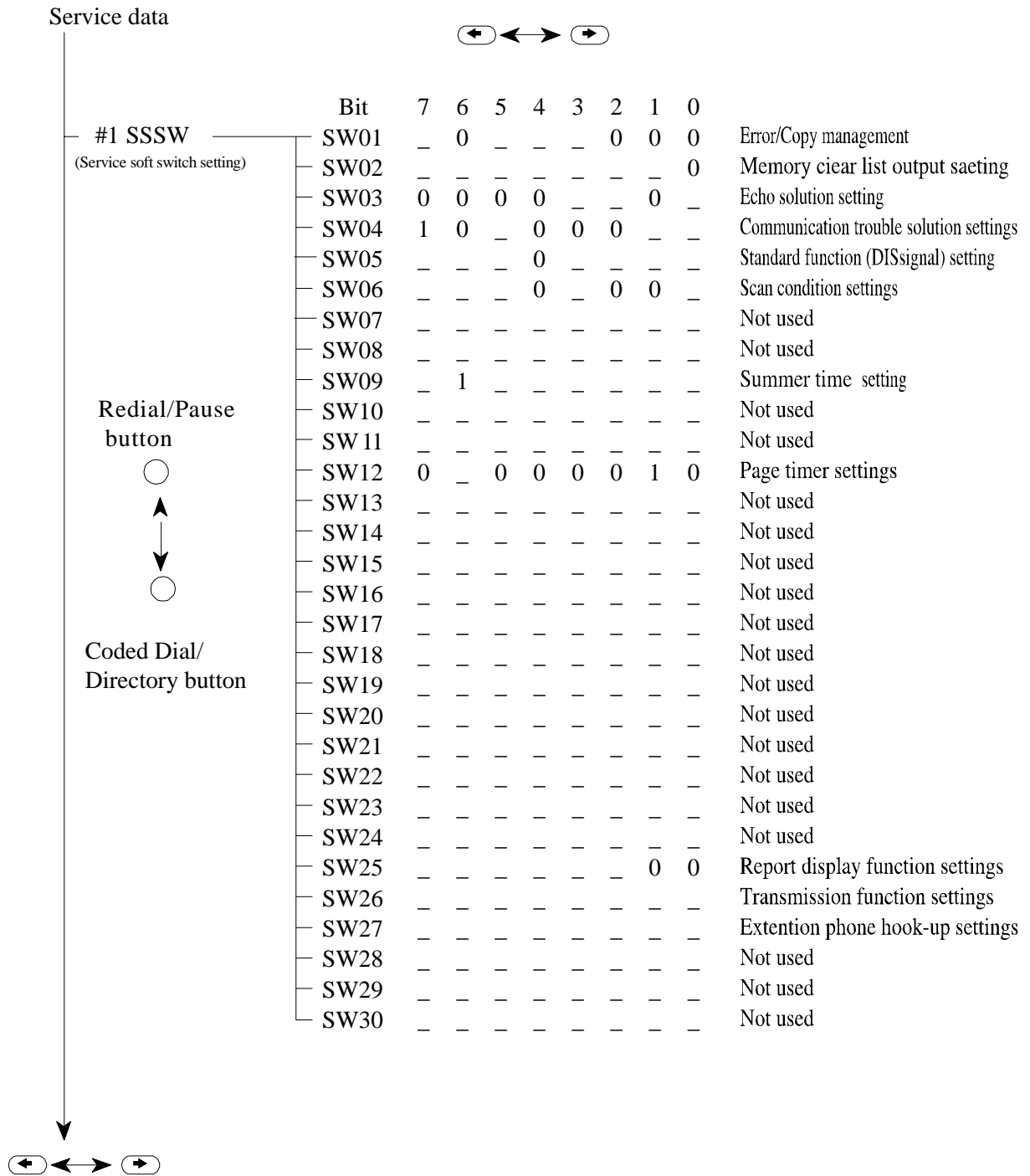

Figure 1-5 Service Data(page 1)

*The switches marked “_” are not used. Do not change their settings.

#2 MENU (Menu switch settings)	01:		Not used
	02:		Not used
	03:		Not used
	04:		Not used
	05:	<input type="checkbox"/> ON <input checked="" type="checkbox"/> OFF*	NL equalizer setting
	06:	<input type="checkbox"/> DIAL <input type="checkbox"/> SER VICEMAN <input checked="" type="checkbox"/> OFF*	Line monitor setting
	07:	14 (0-15dBm)	Transmission level setting
	08:		Not used
	09:		Not used
	10:		Not used
	11 :		Not used
	20:		

[*] indicates the default settings

Figure 1-6 Service data (page 2)

*Nos. 01 to 04 and 08 to 20 are not in use. Please do not change these settings.

#3 NUMERIC PARAM.

(Numeric parameter settings)

	Default	Range	
01:	0		Not used
02:	10(10 %)	(1-99)	Not used
03:	15(15 lines)	(2-99)	Not used
04:	12(12 lines)	(1-99)	RTN signal transmission condition
05:	4		Not used
06:	1		Not used
07:	350		Not used
08:	0		Not used
09:	6		The number of digits in telephone number compared against TSI signal to bematched for receiving function
10:	5500(55 seconds)	(0-9999)	Line connection detection time (T0 timer)
11:	3500(35 seconds)	(0-9999)	Not used
12:	0		Not used
13:	0		Not used
14:	0		Not used
15:	120(1200 ms)	(0-999)	Hooking detection time
16:	4(4 seconds)	(0-9)	Pseudo RBT transimission from CML on time until start
17:	100(1000 ms)	(0-999)	Pseudo RBT signal pattern: On time
18:	0(0 ms)	(0-999)	Pseudo RBT signal pattern: On time (short)
19:	400(4000 ms)	(0-999)	Pseudo RBT signal pattern: On time (long)
20:	100(1000 ms)	(0-999)	Pseudo ring pattern: On time setting
21:	0(0ms)	(0-999)	Pseudo ring pattern: On time (short)
22:	400(4000 ms)	(0-999)	Pseudo ring pattern: On time (long)
23:	4	(0-9)	FAX/TEL switching function signal detection level
24:	10	(0-20)	Pseudo-RBT signal transmission level
25:	60(60 seconds)	(0-999)	Answering machine connection function signal detection time
26:	3	(0-9)	Answering machine connection function no sound detection level
27:	20		Not used
28:	0		Not used
29:	0		Not used
30:	15		Not used

Figure 1-7 Service data(page 3)

*No. 01, 05,06,08,12,14,27-30 are not used. Do not change their settings.

#3 NUMERIC PARAM.

The relationship between the settings and the detection levels is as follows:

Parameter 23

0: -26 dBm 1: -30 dBm 2: -32 dBm 3: -35 dBm 4: -38 dBm

5: -41 dBm 6: -43 dBm 7: -45 dBm 8: -47 dBm 9: -51 dBm

Parameter 24

0: Not used 1: Not used 2: Not used 3: Not used 4: Not used

Parameter 26

0: -30 dBm 1: -34.5 dBm 2: -36.5 dBm 3: -40 dBm 4: -42 dBm

5: -46 dBm 6: -48 dBm 7: -50 dBm 8: -51 dBm 9: -54 dBm

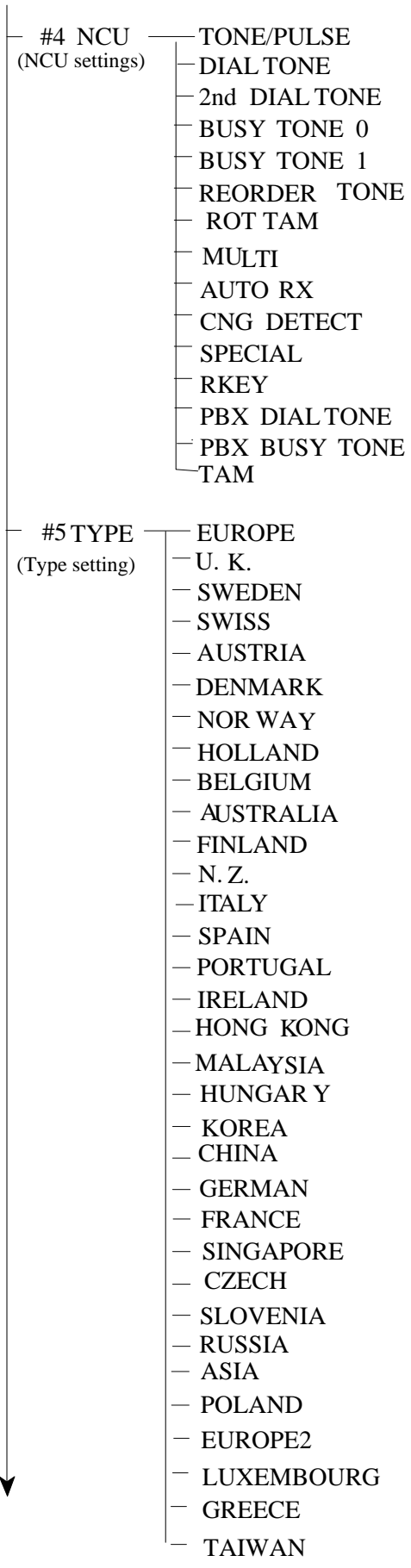

Figure 1-8 Service Data (page 4)

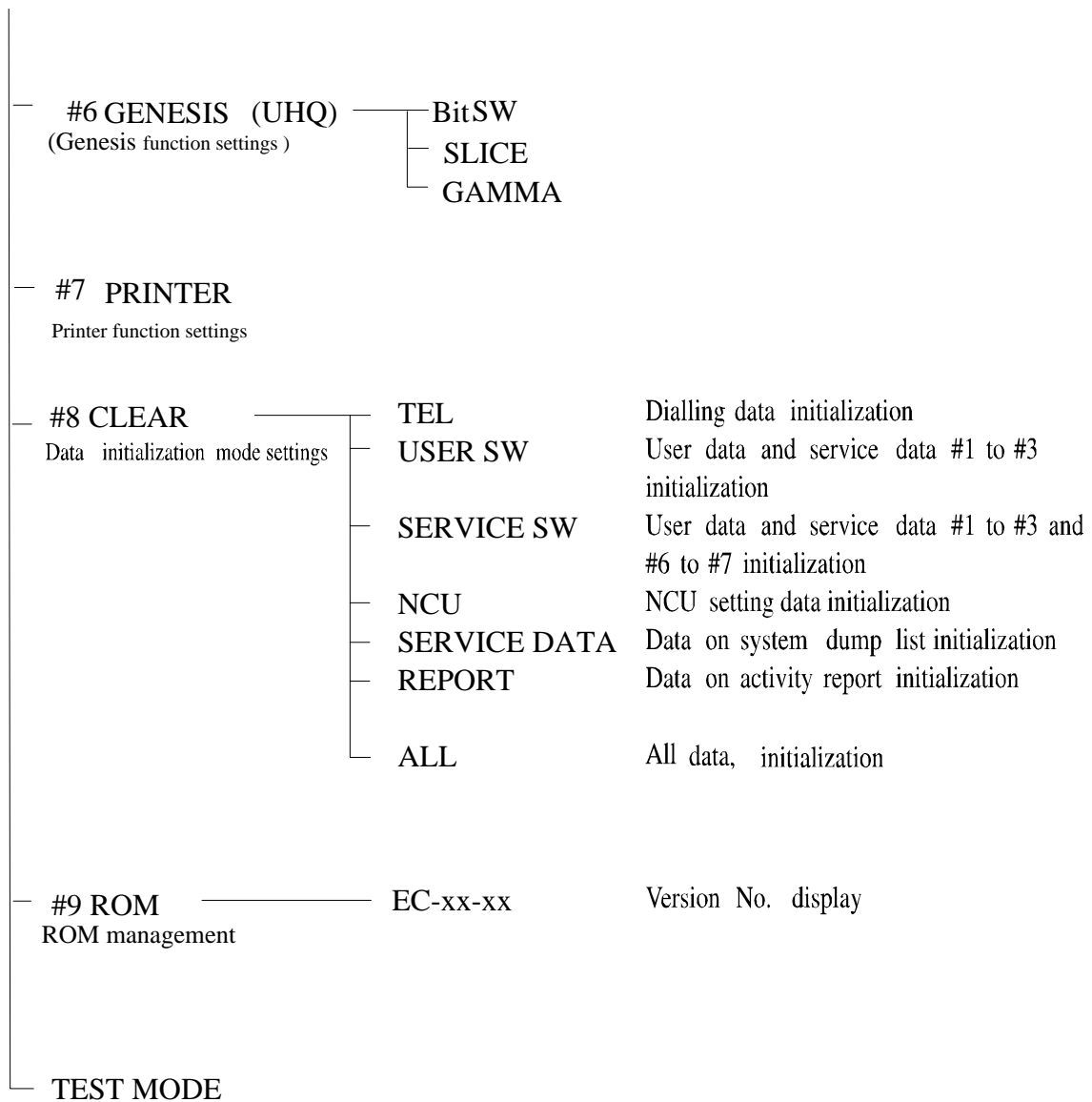

Figure 1-9 Service Data(page 5)

*If USER SW is selected from #8 CLEAR, the memory management of the user data is not cleared.
If TEL or SERVICE is selected, the memory management of the user data is cleared.

3.3 Explanation of service data

SSSW (Service Soft Switch settings)

The items registered and set by each of these switches comprise 8-bit switches. The figure below shows which numbers are assigned to which bits. Each bit has a value of either 0 or 1.

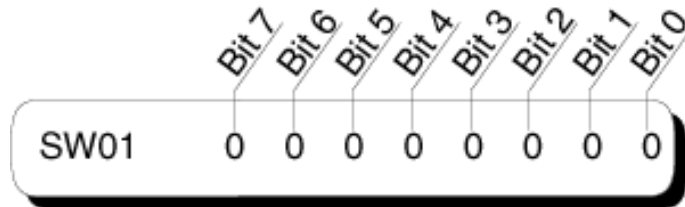

Figure 1-10 Bit Switch Display

As for service switch and default values, please refer to the service data menu.

#1 SSW

SW01(Error/Copy Management)

Bit	Function	1	0
	Serviceman Error Code	Output	Not output*
1	Error Dump List	Output	Not output*
2	Not in use		
3	Copy Function	Prohibited	Not prohibited*
4	Not in use		
5	Not in use		
6	Setting of Date/Time by users	Prohibited	Not prohibited *
7	Not in use		

Set value is [1].

Set value is [0].

*indicates default value.

* Do not change default value if function is not in use.

#1 SSW

SW03 (Service Soft Switch03; Echo countermeasure setting)

Bit	Function	1	0
0	Not in use		
1	Echo Protect Tone for Rapid Transmission	Transmit	Does not transmit*
2	Not in use		
3	Not in use		
4	TX Mode; International TX (1)	Yes	No *
5	TX Mode; International TX (2) or International TX (3)	Yes	No *
6	TX Mode	International TX (3)	International TX (2)*
7	Tonal Signal before sending CED signal	Send	Does not send

[Bit 1]

Sending Echo Protect Tone is selectable for rapid transmission V.29 (transmission rate: 9600 bps or 7200 bps) modem signal. If error due to line condition is of frequent occurrence, please choose to send Echo Protect Tone.

*If sending Echo Protect Tone is selected, non-modulation carrier is sent out as synchronized signal before picture transmission for approx. 200ms.

[Bit 7]

Sending the 1080 Hz tonal signal before CED signal is selectable.

If error due to echo is of frequent occurrence when receiving fax from abroad, be sure to choose to send the tonal signal before CED signal.

[Bit 4, 5, 6]

TX Mode; International TX (1), International TX (2), International TX (3) are selectable.

If error due to echo when sending fax overseas is of frequent occurrence, be sure to specify TX mode setting by using service soft switch.

When selecting TX mode using service soft switch, all TX will be international TX mode.

Refer to the table below and select [International TX (1)].

If error still occurs, please select [International TX (2)] and then [International TX (3)].

TX \ Bit	Bit							
	7	6	5	4	3	2	1	0
International TX (1)	*	0	0	1	0	0	*	0
International TX (2)	*	0	1	0	0	0	*	0
International TX (3)	*	1	1	0	0	0	*	0

* 0 or 1 (depending on each setting)

International TX (1) ignores the first DIS signal sent from the other party.

International TX (2) sends out the 1850 Hz tonal signal at the same time when the other party sends out DIS signal.

International TX (3) sends out the 1650 Hz tonal signal at the same time when the other party sends out DIS signal.

SSSW

SW04(Service Soft Switch04; Countermeasures against Exchange Trouble)

Bit	Function	1	0
0	Not in use		
1	Not in use		
2	The number of the last flag sequence of procedure signal	2	1*
3	RX Mode of sending CFR signal	Fast	Fast/Slow *
4	Duration of ignoring low speed CFR signal	1500ms	700ms *
5	Not in use		
6	CNG signal when manual TX is set	Dose not send	Send *
7	CED signal when manual RX is set	Does not send	Send *

[Bit 2]

It is possible to select the number of last flag sequence of procedure signal (transmission rate: 300 bps).

If the other party is unable to received procedure signal properly, please select 2 for the number of the last flag sequence.

[Bit 3]

It is possible to select RX Mode after sending out CFR signal.

If reception error due to line condition occurs, please select [Fast] for RX Mode. If [Fast] is selected, be sure to undo ECM reception of # SSSW SW05.

* If [Fast] is selected, the machine receives only image signals after sending out CFR signal.

[Bit 6]

It is possible to choose to send out CNG signal when manual TX is set. If the document is sent manually to the machine with [FAX/TEL AUTO SW] mode selected.

[Bit 7]

It is possible to send out CED signal when manual RX is set.

Even if manual RX is set, please choose to send out CED signal when the other party does not start transmitting the document.

#1 SSSW

SW05 (Service Soft Switch05; Standard Feature <DIS signal> setting)

Bit	Function	1	0
0	Not in use		
1	Not in use		
2	Not in use		
3	Not in use		
4	Length of Print Media indicated by DIS signal	A4/B4 size	Any size
5	Indication of LTR/Legal by DIS signal	No	Yes *
6	Sending ECM	No	Yes *
7	Sending ECM	No	Yes *

[Bit 4]

It is possible to select A4/B4 as the print media length to be indicated by DIS signal.

If the machine is to receive a banner paper-size document, be sure to select A4/B4 as the media size to receive it dividing it into 2 pages

*When selecting A4/B4, a DIS signal notifying that the A4 or B4 recording papers are available is sent to the transmitting machine. After receiving the DIS signal, the transmitting machine divides the long-size document into A4 or B4 size, and then sends the document to the receiving machine. Some models of transmitting machines may not divide a long-size document.

[Bit 6]

It is possible to select ECM TX.

If ECM TX is not set, ECM TX is disabled.

[Bit 7]

It is possible to select ECM RX.

If ECM RX is not set, ECM RX is disabled.

#1 SSSW

SW06 (Service Soft Switch06; Setting Scanning Condition)

Bit	Function	1	0
0	Not in use	No	Yes
1	Pre-scan before scanning the document	No	Yes*
2	Limit on Length of Document	No	Less than 1meter *
3	Not in use		
4	Not in use		
5	Not in use		
6	Copy Resolution	Selectable	Fixed *
7	Not in use		

[Bit 0]

It is possible to set the machine to deliver the document after DES (Document Edge Sensor) is activated.

* If [No] is selected, it would lead to a blank space at the edge of the printout because start of scanning document is delayed (by the length corresponding to the distance that the document not being delivered.)

[Bit 1]

It is possible to set the machine to pre-scan when the machine starts scanning the first page of the document.

* If [No] is selected, the machine pre-scan only when the machine is turned ON.

If [Yes] is selected, the machine pre-scan when the machine is turned ON and when the machine starts pre-scanning the first page of the document.

[Bit 2]

It is possible to set the limit on the length of the document.

If copying or sending the document whose length is 1m or longer, please select [No]

* If [No] is selected, the machine is unable to detect (document) paper jam.

[Bit 5]

When memory copying the banner paper-size document, it is possible to select copying only the first page of the document or to divide the document into pieces to copy.

SW09 (Service Soft Switch09; Summer time setting)

Bit	Function	1	0
0	Not in use		
1	Not in use		
2	Not in use		
3	Not in use		
4	Not in use		
5	Not is use		
6	Summer time setting	On	Off
7	Not in use		

#1 SSSW

SW12 (Service Soft Switch12; Page Timer Setting)

Bit	Function	1	0
0	TX Page Timer (When image mode is set to letters)	1	0*
1	TX Page Timer (When image mode is set to letters)	1*	0
2	TX Page Timer (When image mode is set to anything other than letters)	1	0*
3	TX Page Timer (When image mode is set to anything other than letters)	1	0*
4	RX Page Timer	1	0*
5	RX Page Timer	1	0*
6	Not in use		
7	Page Timer setting by TX/RX	Yes	No

Use this SW to set Page Timer.

The machine halts communication if TX/RX takes 32 minutes or longer.

Please select appropriate time setting is TX/RX takes more than 32 minutes.

If [No] is selected for Bit 7, timeout period is determined by Bit 0 and Bit 1 in any mode.

Timeout Period of TX and RX	Bit							
	7	6	5	4	3	2	1	0
8 minutes	0	*	*	*	*	*	0	0
16 minutes	*	*	*	*	*	*	0	1
32 minutes	0	*	*	*	*	*	1	0
64 minutes	0	*	*	*	*	*	1	1

TX Timeout Period (Image Mode: Letters)	Bit							
	7	6	5	4	3	2	1	0
8 minutes	0	*	*	*	*	*	0	0
16 minutes	0	*	*	*	*	*	0	1
32 minutes	0	*	*	*	*	*	1	0
64 minutes	0	*	*	*	*	*	1	1

TX Timeout Period (Image Mode: Other than Letters)	Bit							
	7	6	5	4	3	2	1	0
8 minutes	1	*	*	*	0	0	*	*
16 minutes	1	*	*	*	0	1	*	*
32 minutes	1	*	*	*	1	0	*	*
64 minutes	1	*	*	*	1	1	*	*

RX Timeout Period	Bit							
	7	6	5	4	3	2	1	0
8 minutes	1	*	0	0	*	*	*	*
16 minutes	1	*	0	1	*	*	*	*
32 minutes	1	*	1	0	*	*	*	*
64 minutes	1	*	1	1	*	*	*	*

* 0 or 1 (depending on each setting)

#1 SSSW

SW25 (Service Soft Switch25: Report display Function Settings)

Bit	Function	1	0
0	Transmission telephone numbers display on reports	Other fax number	Called number*
1	Other party ID display on reports	Otherfax ID from	Registered ID*
2	Not in use		
3	Not in use		
4	Not in use		
5	Not in use		
6	Not in use		
7	Not in use		

[Bit 3]

In order to prevent a unintended broadcast fax due to users' operation mistake, broadcast fax is disabled.

However broadcast fax using Group Dialing is enabled regardless of settings.

3.4 Test Function

3.4.1 User Test Print Function

User enabled Test print functions are as follow.

3.4.2 Service Test Functions

The fax functions for testing individual operations, such as below. See 3-2-4 Service Data Setting Method.

To leave the test mode, press the Function button, and then Clear button.

3.4.3 Test mode overview

Test mode can be executed by following the menu items from the display.

a) DRAM tests

Writes data to DRAM image storage areas and reads that data to check operations.

b) Modem, NCU tests

Test frequency, G3 signal transmission and CNG signal transmission.

c) Faculty tests

Test the operation of operation panel and sensor functions.

d) Remaining ink detection test

Tests level of remaining ink and initializes ink sensor.

e) Flash memory test

Performs READ/WRITE operation in flash memory TAM memory area, to check whether operation is correct or not.

f) Printer test

Test the operation of the printer functions.

3.4.4 Test mode menu

TEST MODE [1] - [8]

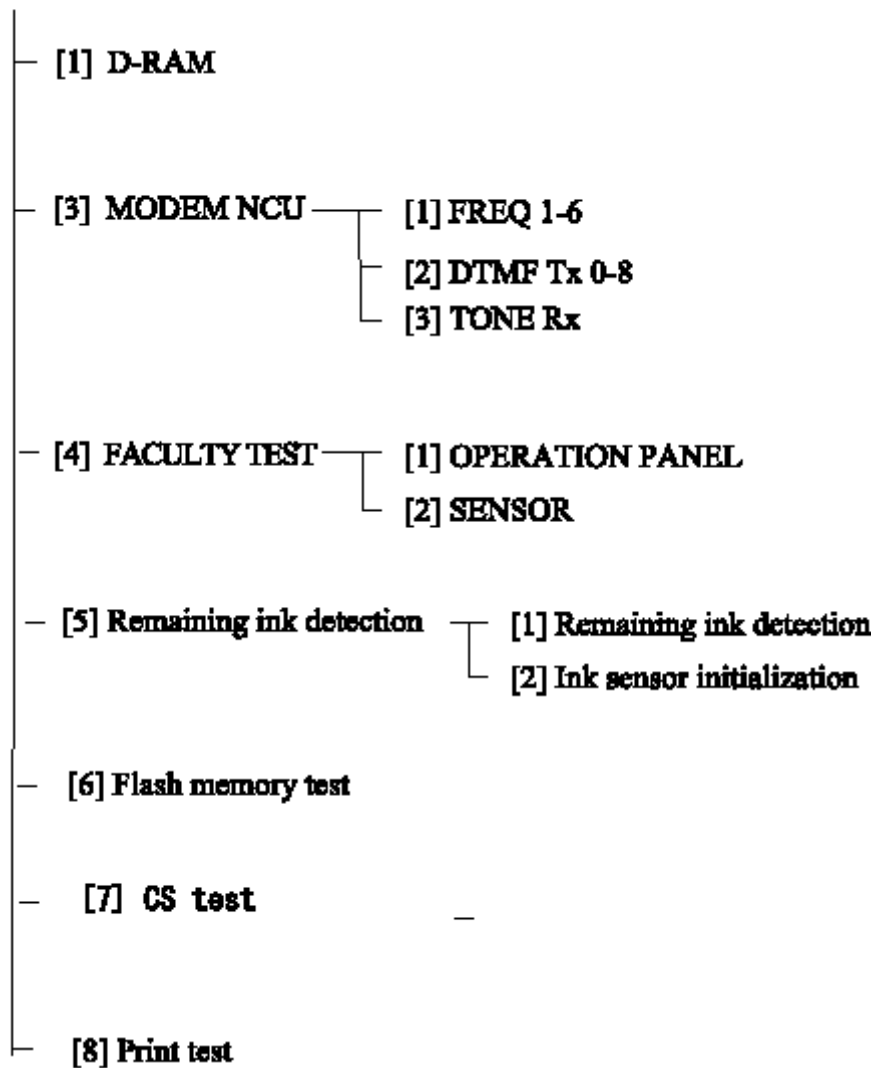

Figure 1-11 Test mode

3.4.5 DRAM test

In the test mode menu, press numeric button '1' and select the DRAM test mode. DRAM test 1 writes and reads data into and from all areas of the DRAM and checks that the operation is normal.

DRAM test 2 performs data read only, at high speed.

In the event of an error, replace the SCNT board.

Testing

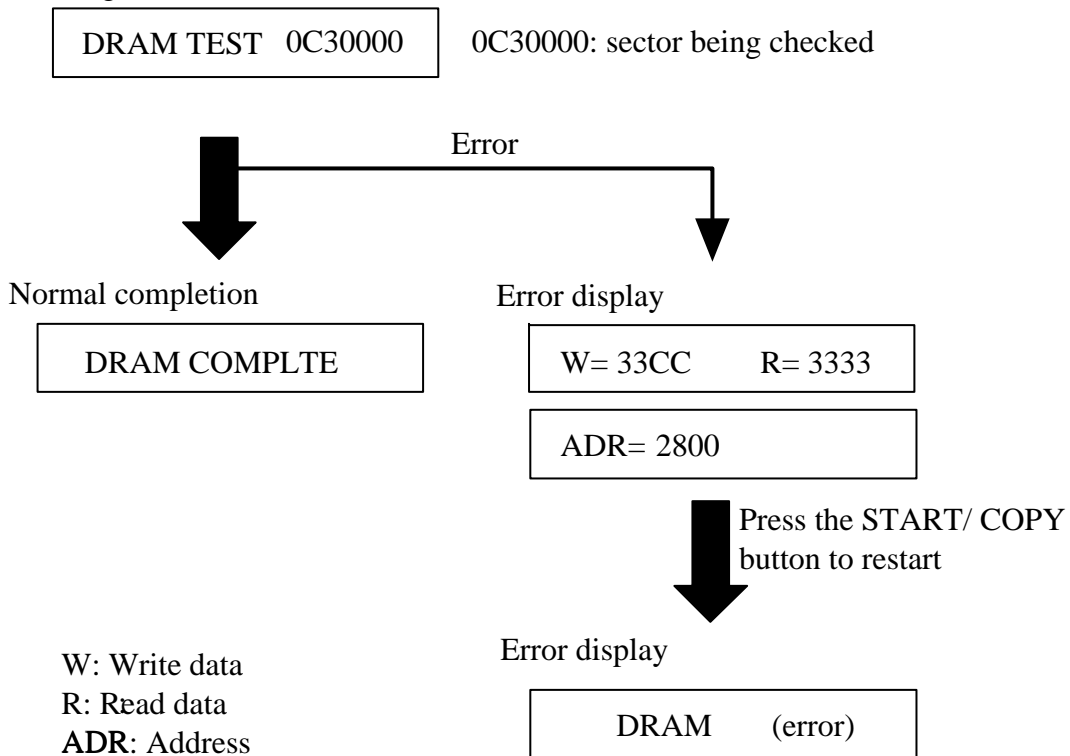

Figure 1-12 DRAM test

3.4.6 MODEM, NCU test

In the test mode menu, press numeric button '3' and select the MODEM, NCU test.

This test runs transmission and reception tests on the modem and NCU. In the MODEM test, listen to the signal sounds from the speaker to check whether the signals output by the modem are correctly transmitted. Press the STOP button to end the test.

Modem test	Description
Frequency test	A tonal signal is output from the modem via the telephone line connection terminal and the speaker.
G3 signal output test	A G3 signal is output from the modem via the telephone line connection terminal and the speaker.
Tone signal reception test	The modem detects particular frequencies of signals received via the telephone line connection terminal.

a) Frequency test

In the MODEM, NCU test menu, press numeric button '1' and the frequency test is selected.

In this test, the following frequencies are output from the modem via the telephone line connection terminal and the speaker. The frequencies can be changed using the numeric buttons.

Numeric button	Frequency
1	1100 Hz
2	1300 Hz
3	1500 Hz
4	1650 Hz
5	1850 Hz
6	2100 Hz

b) G3 signal output test

In the MODEM, NCU test menu, press numeric button '2' and the G3 signal output test is selected.

A G3 signal is output from the modem via the telephone line connection terminal and the speaker.

The transmission speed can be changed using the numeric buttons.

Numeric button	Speed
0	300 bps
1	2400 bps
2	4800 bps
3	7200 bps
4	9600 bps
5	TC7200 bps
6	TC9600 bps
7	12000 bps
8	14400 bps

*The output level for each frequency depends on the service data output level settings.

c) Tone signal RX test

In FAX MODEM TEST menu, press numeric key 3 to select Tonal Signal RX Test.

This test checks that modem detects tonal signal sent via telephone line terminal.

Method:

- 1) Prepare another machine and connect its telephone line terminal with that of machine under test using modular jack.
- 2) Both machines: enter FAX MODEM TEST menu.
- 3) Machine under test: select [Tone Signal Reception Test] mode.
- 4) Other machine: select [Frequency Test] mode, and set the machine to send out 1100 Hz (CNG) and 1300 Hz (FC).
- 5) Machine under text: check if the machine can detect 1100 Hz (CNG) and 1300 Hz (FC) sent from the other machine.

Tone Signal Reception Test



n=None: when the machine detects 1300 Hz signal

n=5 : when the machine detects DTMF 5

n=56 : when the machine detect 6 following DTMF 5

Figure1-13 Tonal Signal Reception Test

3.4.7 FACULTY (function) test

In the test mode menu, press numeric button '4' and select the FACULTY test.

This checks the following functions.

Test	Description
Control panel test	Checks whether the control panel buttons are working properly.
Sensor test	Checks whether the sensors are working properly.

a) Control panel test

From the FACULTY test menu, press numeric button '1' and select the control panel test.

This test checks whether the display, LED and control panel buttons are working properly.

a-1) Display test

From OPERATIONAL PANEL menu, press the [Start/Copy] button, and the 16 letters of [H] are displayed in the first line of LCD. Press the [Start/Copy] button again, and the 16 letters of [X] are displayed. If the [Start/Copy] button is pressed once again, letters on LCD change to 16 black squares. Check if all LC dot are displayed on LCD.

a-2) Control panel button test

In this test, the operator presses the button that corresponds to the displayed character.

When the button is pressed, the character disappears.

The table of characters and buttons is as shown below.

Check that all of the characters disappear when the appropriate buttons are pressed.

Character	Button	Character	Button
1	1(Numeric button)	M	Reception mode button
2	2(Numeric button)	R	Resolution button
3	3(Numeric button)	F	Function button
4	4(Numeric button)	L	← (L button)
5	5(Numeric button)	R	→ (R button)
6	6(Numeric button)	T	TAM
7	7(Numeric button)	D	DEL button
8	8(Numeric button)	R1	REC button
9	9(Numeric button)	P	PLAY
*	*(Numeric button)	R2	Redial button
0	0(Numeric button)	V	U Can Talk
#	#(Numeric button)	C	Speed dial
a	01(Once touch dial button)	O	Hook
b	02(Once touch dial button)	S	Start/Copy button
c	03(Once touch dial button)		
d	04(Once touch dial button)		
e	05(Once touch dial button)		
f	06(Once touch dial button)		
g	07(Once touch dial button)		
h	08(Once touch dial button)		
I	09(Once touch dial button)		

b) Sensor test

From the FACULTY test menu, press numeric button '2' and select the sensor test.

This test checks whether the sensors are working properly.

1. DS of HOOK on (Displayed OFF or ON)
2. PES of RRP on (Displayed OFF or ON)
3. HPS of IS on (Displayed OFF or ON)

LCD	Sensor
D Document sensor	(DS)
P Paper edge sensor	(PES)
R ASF position sensor	(PRS)
H Carriage home position sensor	(HPS)

Displayed OFF or ON. As for the ink amount, OFF means no ink and ON means ink remaining, and # means ink level adjustment required.

3.4.8 Ink Amount Detection

From the TEST mode menu, press numeric button '5' and select the remaining detection test.

Test check the following functions.

Test	Description
[1] Remaining ink detection	Displays the current ink sensor value and the ink sensor initial registration value.
[2] Ink sensor initialization	Initializes ink sensor

INK CHECK [1]-[2]

Select numeric button [1] or [2]

[1] Remaining ink detection LCD display

1. INS Current ink sensor value/ink sensor initial registration value.

2. INK=NO/YES [nnn]

Yes: Ink remaining/ NO: No ink remaining

nnn: Current ink sensor value / ink sensor initial registration value x 100

1: and 2: displayed alternately.

[2] Ink sensor initialization

Press the START button to begin initialization.

* Be sure to install cartridges with ink full before initialization.

3.4.9 Flash memory test

Selected

FMEM TEST

If the flash memory test contains audio data, the LCD display asks whether the data may be deleted.

Testing

R/W CHEK START!

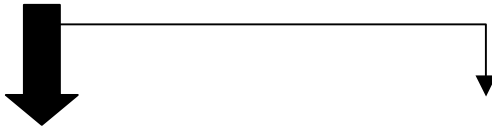

Normal completion

Complete (no error)

Error display

WR= AA

RD=33

ADR=2800

Press the START/COPY button to restart.



Error display

FMEM (error)

WRT: Write data

RD: Read data

ADR: Address

Figure1- 14 Flash memory test

From the test mode menu, press numeric '1' and select the flash memory test.

This test writes and reads data into and from all areas of the flash memory and checks that the operation is normal. In the event of an error, replace the SCNT board.

Part 2

Technical Reference

1. New Technology

Cross-Section Diagram

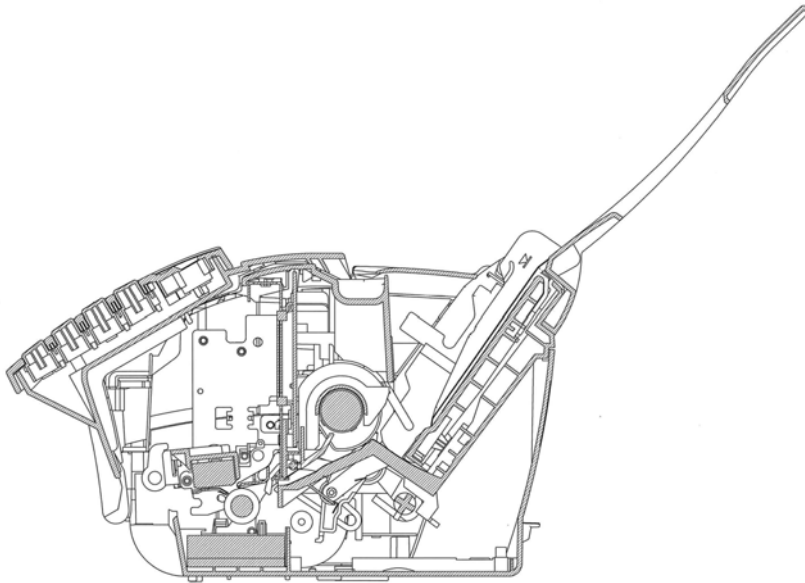

(1) One-path Function

This machine employs [Onepath] system to use a single roller to pick up the document as well as to separate recording papers. It is possible to load the document and recording papers at the same time. When copying, please load recording papers before setting the document. The machine prints the copy after scanning the document.

* Recording operation (including FAX reception) is not performed when a document is set.

Part 3

Appendix

1. Schematic

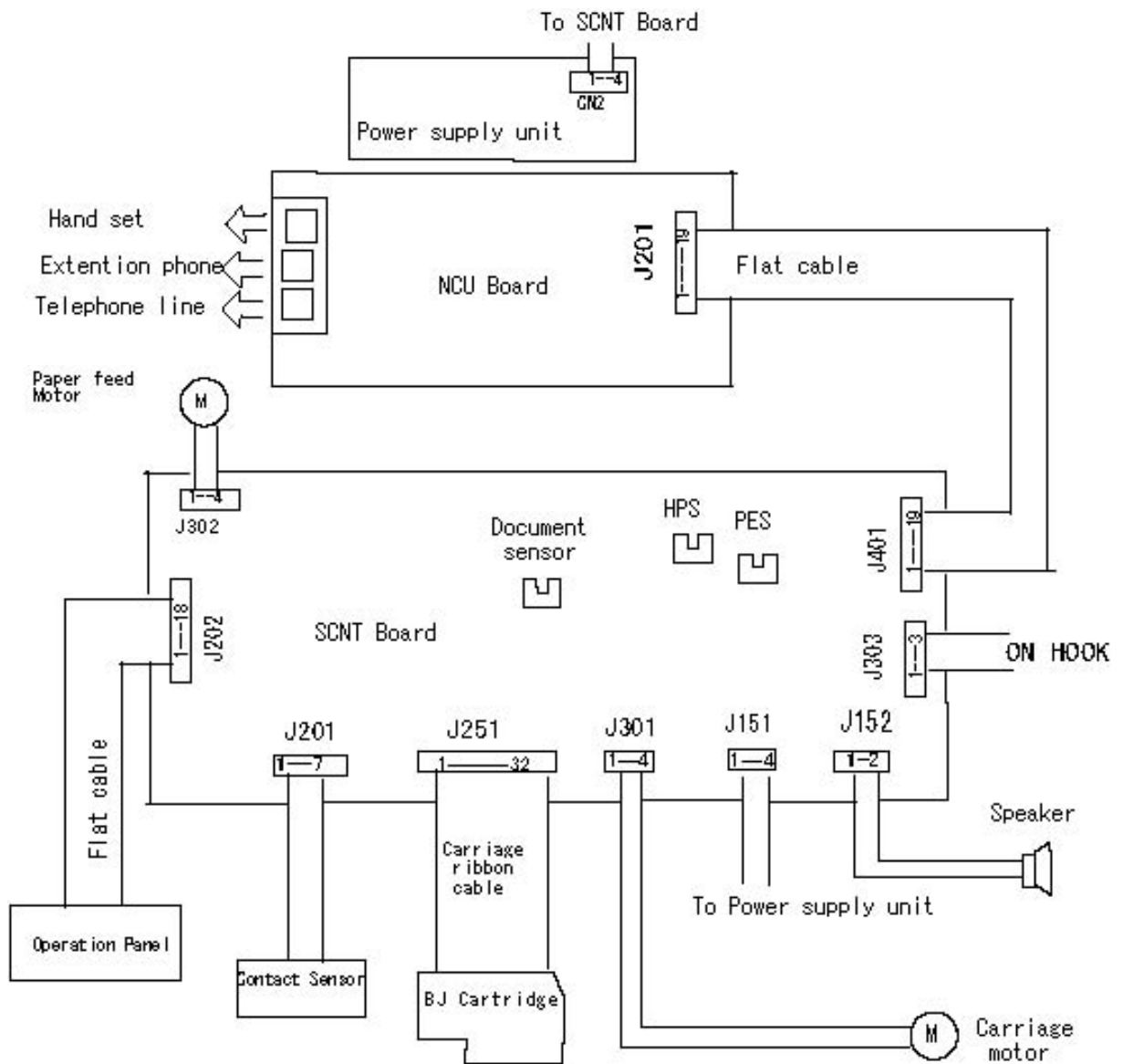

2. Specifications

Fax-B820/B822/B840		
Item	FAX-B820/B822	FAX-B840
Facsimile		
Applicable Line		
PSTN	Yes	←
ISDN	No	←
Others(private line, etc.)	No	←
Applicable service		
F Net16Hz(JPN)	No	←
F Net1300Hz(JPN)	No	←
DI Service (JPN)	No	←
Mercury (UK)	No	←
Econophone (SPAIN)	No	←
Hong Kong Telephone(HK)	Yes	←
DRPD (USA)	No	←
Caller ID	Yes	←
NET SWITCH (Australia)	Yes	←
Own Ringing(Fin)	Yes	←
FAX ABILITY (New Zealand)	Yes	←
Compatibility		
G4	No	←
G3	Yes	←
Color Fax Transmission	No	←
Data compression system		
B/W	MH, MR, MMR	←
Color	No	←
ECM	Yes	←
Modem		
Type	FAX modem	←
Speed	14,400bps(TX only)	←
ITU recommendation	V.17, V.29, V.27ter, V.21	←

Fax-B820/B822/B840		
Item	FAX-B820/B822	FAX-B840
Facsimile		
Transmission speed		
Canon Standard Chart	6 seconds (TX)	←
CCITT (ITU-T) No.1 Chart	6 seconds	←
Canon express protocol	No	←
FAX resolution		
Transmission(pel/mm×line/mm)	8 × 3.85 , 7.7	←
Reception(pel/mm×line/mm)	8 × 3.85 , 7.7	←
Scanning image processing		
GENESIS / UHQ	Yes	←
No. of halftone levels	64 levels	←
Automatic image adjustment	No	←
Document Mode	No	←
Density adjustment level	Yes	←
Multi-level Resolution Conversion	Yes	←
Automatic Density Adjustment	No	←
Fax scanning speed		
sec./page(A4, Standard)	16.3 sec./page	←
page(s)/min	3.69 page(s)/min	←

Fax-B820/B822/B840			
Item		FAX-B820/B822	FAX-B840
Printer			
Printing method		Bubble jet	←
Printing resolution		360dpi×360dpi	←
Paper capacity			
Cassette	Cassette size	No	←
	Cassette capacity	No	←
Manual feed		Yes	←
Tray Size	Tray Size	LTR/LGL/A4	←
	Tray Capacity	50 sheets	←
Paper size		LTR/LGL/A4	←
Color Printing		No	←
Printing speed			
sec/ page		39 sec/ page	←
page(s) /min		1.54 page(s) /min	←
Printing width		Max. 203 mm	←
BJ FAX Cartridge		Ink/Head	←
Product name		BX-3 Cartridge	←
Capacity (BLK)		Approx. 850 pages	←
Toner or ink saving		Yes	←
Method		Draft Mode	←
Pages		Approx. 1500 pages	←
Stacker	Pages	No	←
	Type	No	←
PDL		No	←
DOS Print		No	←
Printing image processing		Yes	←
Smoothing		No	←
Resolution conversion		Yes	←
Printing pixel correction		No	←

Fax-B820/B822/B840		
Item	FAX-B820/B822	FAX-B840
Dialing/key		
Telephone Handset	Yes	←
Manual 10-key dialing	Yes	←
On-Hook key	Yes	←
Reception Mode key	Yes	←
Automatic dialing	Yes	←
One-Touch Speed dialing	9	←
Coded-Speed dialing	70	←
Programmable Number of digits	20 average	
Group dialing	No	←
Program dialing	No	←
Dial search	Yes	←
Hold key	No	←
Tone Dialing key	Yes	←
Pause key	Yes	←
DT key	No	←
R key (230V)	Yes	←
Prefix	Yes	←
Flash	Yes	←
Earth	No	←
Set key	Yes Use as Start button	←
Clear key	Yes	←
Redial key	Yes	←
Function key	Yes	←
Copy key	Yes Use as Start button	←
Cursor key	Yes	←
ESS key	No	←
Help key	No	←
F Net key (JPN)	No	←
Pin Code key (USA)	No	←
M/E key (UK/SPAIN)	No	←

Fax-B820/B822/B840			
Item	FAX-B820/B822	FAX-B840	
Telephone Switch			
FAX/TEL auto switch			
Detecting signal			
Yes			
←			
CNG			
←			
OGM1	Method	No	Yes
	Message	No	Need to record
	Language	No	←
OGM2	Method	No	←
	Message	No	←
	Language	No	←
P-Ci			
No			
←			
Auto RX w/o ring			
Yes			
←			
Built-in answering machine			
No			
Yes			
Method			
Digital			
←			
OGM			
No			
Need to record			
Message	No. of messages	No	50(include OGM)
	Time of messages	No	10 minutes (total minutes)
Answering machine Hook-up			
No			
Yes			
Detecting signal			
No			
CNG			
Remote reception			
Yes			
←			
Dialing	Yes		←
	Code	25 (Default)	←
On hook			
No			
←			
Extension phone hook-up			
Yes			
←			
BT (NTT)			
No			
←			
Wall Connection (GER, AST, SWI)			
Yes			
←			
Speakerphone			
No			
←			
Phone call at power failure			
No			
←			

Fax-B820/B822/B840		
Item	FAX-B820/B822	FAX-B840
Memory capacity	1.6MB	←
Type	DRAM	←
Page		
Canon Standard Chart	120 pages	←
CCITT (ITU-T) No.1 Chart	120 pages	←
Storage Method	Depend on receiving mode	
Option	No	←
Indicating amount of memory use	No	←
Memory Back-up	No	←
No	No	←
Transmission		
Direct transmission	Yes	←
Memory transmission	Yes	←
Page		
Canon Standard Chart	120 pages	←
CCITT (ITU-T) No.1 Chart	120 pages	←
Quick memory TX	No	←
Direct transmission when memory is full	No	←
Dual access	No	←
Max. File No. of reservation	No	←
Time sharing dial	No	←
Memory	Yes (30 orders)	←
TX reservation	No	←
Direct	No	←
Batch transmission by destination	No	←

Fax-B820/B822/B840		
Item	FAX-B820/B822	FAX-B840
Transmission		
Polling TX	No	←
Direct	No	←
Memory	No	←
Bulletin board function	No	←
Sequential broadcasting	Yes	←
Max. no. of destinations	Max. 80	←
Delayed transmission	Yes	←
No. of destinations	80	←
No. of reservation	1	←
Batch transmission	No	←
No. of destinations	No	←
Time setting	No	←
Confidential transmission	No	←
Relay broadcasting command	No	←
Password/ Sub address sending	No	←
Sub address	No	←
Selective polling	No	←
Password	No	←
Error retransmission	No	←
Auto redial	Yes	←
Times	Variable	←
Interval	Variable	←
Error redialing	No	←

Fax-B820/B822/B840		
Item	FAX-B820/B822	FAX-B840
Reception		
Memory reception	Yes	←
Page		
Canon Standard Chart	120 pages	←
CCITT (ITU-T) No.1 Chart	120 pages	←
Alarm	No	←
Automatic output	Yes	←
Memory lock reception	No	←
Time setting	No	←
Multiple printing	No	←
Polling reception	Yes	←
Timer polling	No	←
Confidential mailbox	No	←
Relay broadcasting	No	←
Transfer	No	←
Received image reduction	Yes	←
Fixed	Yes	←
Automatic reduction	No	←
Main & Sub	No	←
Reduction ratio	No	←
Collating	No	←
N in 1 reception	No	←
DM preventive function	Yes	←
Others		
DTMF remote	No	←
Closed Network	No	←
System Management password	No	←
Management by section	No	←

Fax-B820/B822/B840		
Item	FAX-B820/B822	FAX-B840
Others		
Use restriction	No	←
Calling	No	←
Transmission	No	←
Printing	No	←
Reports and lists		
Activity result report	Activity result, phone number, abbr. TX start date, TX period, pages	
Activity management report	Number: 20, phone number, abbr., by TX/RX, TX period, Activity result	
Memory Clear List	RX mode, phone number, abbr., RX date, pages	
System Dump List	Output in Service Mode	
Display		
Type	LCD	←
Size	16 × 1	←
Chinese character	No	←
Languages		
LCD	One of 16 languages	←
Report	One of 16 languages	←
Operation panel	Pictogram	←
Transmission header	Yes	←
Reception footer	No	←
Keep printing during low toner supply	No	←
Self-demonstration function	No	←
Help function	No	←
Clock	Yes	←
Verification stamp	No	←
Daylight saving time auto switch	Yes	←
RMD	No	←

Fax-B820/B822/B840			
Item	FAX-B820/B822	FAX-B840	
Copy			
Scanning resolution			
Black & White	8×7.7 pel	←	
Color	No	←	
Printing resolution			
Black & White	360 dpi×360 dpi	←	
Color	No	←	
Copy speed			
Black & White	9 4.3 sec/page	←	
Scanning			
	No		
Scanning resolution	8×7.7	←	
Scanning method	CIS	←	
Type	Sheet	←	
Color		←	
Scanning document size	208 mm (A4)	←	
Passing-width	148-216mm	←	
Passing-length	105-700mm	←	
Scanning time	sec/page	16.3 sec/page	←
	pages/min	3.69 pages/min	←
ADF	A4,Letter	15 pages	←
	B4	No	←
	Legal	5 pages	←
Gray scale	No	←	
Color	No	←	
TWAIN	No	←	

Fax-B820/B822/B840		
Item	FAX-B820/B822	FAX-B840
General		
Power Consumption		
Maximum	33.1W	←
Standby	3.2W	←
Low Power Consumption Design	No	←
Method	No	←
Power Consumption	No	←
Noise		
Maximum(Copy)	50db	←
Standby	--	←
Durability		
Unit	18,000 Sheets or 5 years	←
Scanning Section	18,000 Sheets or 5 years	←
Printing Section	18,000 Sheets or 5 years	←
Applicable Standard		
Electrical	GS	←
Radiation Noise		
EMC	CISPR Pub22 Class B	←
Immunity	--	←
PTT	Yes	←
Power Saving	Energy Star	←
Environment	No	←
Accessibility	No	←
Others	CE Mark	←
External Dimension (W×D×H)		
Including Handset, Tray	W366 ×D381 ×H265	←
No Handset, Tray	W366 × D261 ×H161	←
Weight	Standard	Approx. 3.5 kg