



KONICA MINOLTA

SERVICE MANUAL

THEORY OF OPERATION

bizhub 164

THEORY OF OPERATION TOTAL CONTENTS

SAFETY AND IMPORTANT WARNING ITEMS	S-1
IMPORTANT NOTICE	S-1
DESCRIPTION ITEMS FOR DANGER, WARNING AND CAUTION	S-1
SAFETY WARNINGS	S-2
WARNING INDICATIONS ON THE MACHINE	S-17
MEASURES TO TAKE IN CASE OF AN ACCIDENT	S-19
Composition of the service manual	C-1
Notation of the service manual	C-2

bizhub 164 main body

OUTLINE	1
COMPOSITION/OPERATION.....	9

Blank Page

SAFETY AND IMPORTANT WARNING ITEMS

Read carefully the safety and important warning items described below to understand them before doing service work.

IMPORTANT NOTICE

Because of possible hazards to an inexperienced person servicing this product as well as the risk of damage to the product, KONICA MINOLTA BUSINESS TECHNOLOGIES, INC. (hereafter called the KMBT) strongly recommends that all servicing be performed only by KMBT-trained service technicians.



Changes may have been made to this product to improve its performance after this Service Manual was printed. Accordingly, KMBT does not warrant, either explicitly or implicitly, that the information contained in this service manual is complete and accurate.

The user of this service manual must assume all risks of personal injury and/or damage to the product while servicing the product for which this service manual is intended.



Therefore, this service manual must be carefully read before doing service work both in the course of technical training and even after that, for performing maintenance and control of the product properly.

Keep this service manual also for future service.













DESCRIPTION ITEMS FOR DANGER, WARNING AND CAUTION

In this Service Manual, each of three expressions “ DANGER”, “ WARNING”, and “ CAUTION” is defined as follows together with a symbol mark to be used in a limited meaning.

When servicing the product, the relevant works (disassembling, reassembling, adjustment, repair, maintenance, etc.) need to be conducted with utmost care.

-  **DANGER: Action having a high possibility of suffering death or serious injury**
-  **WARNING: Action having a possibility of suffering death or serious injury**
-  **CAUTION: Action having a possibility of suffering a slight wound, medium trouble, and property damage**

Symbols used for safety and important warning items are defined as follows:

	:Precaution when servicing the product.		General precaution		Electric hazard		High temperature
	:Prohibition when servicing the product.		General prohibition		Do not touch with wet hand		Do not disassemble
	:Direction when servicing the product.		General instruction		Unplug		Ground/Earth

SAFETY WARNINGS

[1] MODIFICATIONS NOT AUTHORIZED BY KONICA MINOLTA BUSINESS TECHNOLOGIES, INC.

KONICA MINOLTA brand products are renowned for their high reliability. This reliability is achieved through high-quality design and a solid service network.

Product design is a highly complicated and delicate process where numerous mechanical, physical, and electrical aspects have to be taken into consideration, with the aim of arriving at proper tolerances and safety factors. For this reason, unauthorized modifications involve a high risk of degradation in performance and safety. Such modifications are therefore strictly prohibited. The points listed below are not exhaustive, but they illustrate the reasoning behind this policy.

Prohibited Actions

! DANGER

- Using any cables or power cord not specified by KMBT.



- Using any fuse or thermostat not specified by KMBT. Safety will not be assured, leading to a risk of fire and injury.

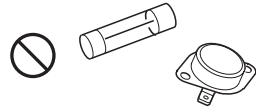

- Disabling fuse functions or bridging fuse terminals with wire, metal clips, solder or similar object.

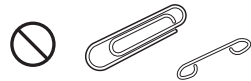

- Disabling relay functions (such as wedging paper between relay contacts).

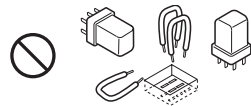

- Disabling safety functions (interlocks, safety circuits, etc.). Safety will not be assured, leading to a risk of fire and injury.

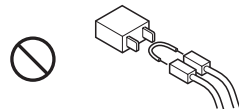

- Making any modification to the product unless instructed by KMBT.



- Using parts not specified by KMBT.

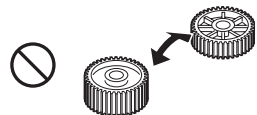

[2] POWER PLUG SELECTION

In some countries or areas, the power plug provided with the product may not fit wall outlet used in the area. In that case, it is obligation of customer engineer (hereafter called the CE) to attach appropriate power plug or power cord set in order to connect the product to the supply.

Power Cord Set or Power Plug

WARNING

- Use power supply cord set which meets the following criteria:
 - provided with a plug having configuration intended for the connection to wall outlet appropriate for the product's rated voltage and current, and
 - the plug has pin/terminal(s) for grounding, and
 - provided with three-conductor cable having enough current capacity, and
 - the cord set meets regulatory requirements for the area.
- Use of inadequate cord set leads to fire or electric shock.



- Attach power plug which meets the following criteria:
 - having configuration intended for the connection to wall outlet appropriate for the product's rated voltage and current, and
 - the plug has pin/terminal(s) for grounding, and
 - meets regulatory requirements for the area.
- Use of inadequate cord set leads to the product connecting to inadequate power supply (voltage, current capacity, grounding), and may result in fire or electric shock.



- Conductors in the power cable must be connected to terminals of the plug according to the following order:
 - Black or Brown:L (line)
 - White or Light Blue:N (neutral)
 - Green/Yellow:PE (earth)



Wrong connection may cancel safeguards within the product, and results in fire or electric shock.

[3] CHECKPOINTS WHEN PERFORMING ON-SITE SERVICE

KONICA MINOLTA brand products are extensively tested before shipping, to ensure that all applicable safety standards are met, in order to protect the customer and customer engineer (hereafter called the CE) from the risk of injury. However, in daily use, any electrical equipment may be subject to parts wear and eventual failure. In order to maintain safety and reliability, the CE must perform regular safety checks.

1. Power Supply

Connection to Power Supply**⚠ WARNING**

- Check that mains voltage is as specified.

Connection to wrong voltage supply may result in fire or electric shock.



- Connect power plug directly into wall outlet having same configuration as the plug.

Use of an adapter leads to the product connecting to inadequate power supply (voltage, current capacity, grounding), and may result in fire or electric shock.

If proper wall outlet is not available, advise the customer to contact qualified electrician for the installation.



- Plug the power cord into the dedicated wall outlet with a capacity greater than the maximum power consumption.

If excessive current flows in the wall outlet, fire may result.



- If two or more power cords can be plugged into the wall outlet, the total load must not exceed the rating of the wall outlet.

If excessive current flows in the wall outlet, fire may result.



- Make sure the power cord is plugged in the wall outlet securely.

Contact problems may lead to increased resistance, overheating, and the risk of fire.

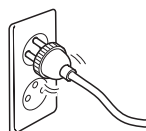

- Check whether the product is grounded properly.

If current leakage occurs in an ungrounded product, you may suffer electric shock while operating the product.

Connect power plug to grounded wall outlet.

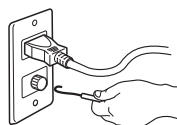

Power Plug and Cord

WARNING

- When using the power cord set (inlet type) that came with this product, make sure the connector is securely inserted in the inlet of the product.

When securing measure is provided, secure the cord with the fixture properly.

If the power cord (inlet type) is not connected to the product securely, a contact problem may lead to increased resistance, overheating, and risk of fire.

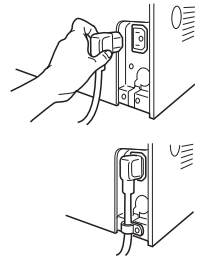

- Check whether the power cord is not stepped on or pinched by a table and so on.

Overheating may occur there, leading to a risk of fire.

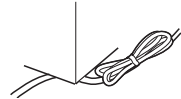

- Check whether the power cord is damaged. Check whether the sheath is damaged.

If the power plug, cord, or sheath is damaged, replace with a new power cord (with plug and connector on each end) specified by KMBT. Using the damaged power cord may result in fire or electric shock.

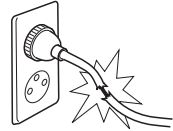

- Do not bundle or tie the power cord.

Overheating may occur there, leading to a risk of fire.

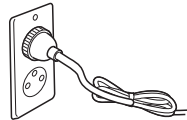

- Check whether dust is collected around the power plug and wall outlet.

Using the power plug and wall outlet without removing dust may result in fire.

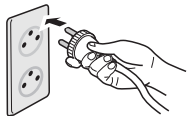

- Do not insert the power plug into the wall outlet with a wet hand.

The risk of electric shock exists.



- When unplugging the power cord, grasp the plug, not the cable.

The cable may be broken, leading to a risk of fire and electric shock.

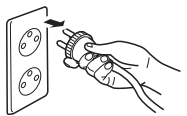

Wiring

WARNING

- Never use multi-plug adapters to plug multiple power cords in the same outlet.

If used, the risk of fire exists.

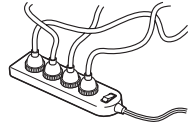

- When an extension cord is required, use a specified one. Current that can flow in the extension cord is limited, so using a too long extension cord may result in fire.

Do not use an extension cable reel with the cable taken up. Fire may result.



2. Installation Requirements

Prohibited Installation Places

WARNING

- Do not place the product near flammable materials or volatile materials that may catch fire.

A risk of fire exists.

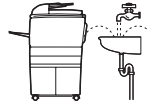

- Do not place the product in a place exposed to water such as rain.

A risk of fire and electric shock exists.



When not Using the Product for a long time

WARNING

- When the product is not used over an extended period of time (holidays, etc.), switch it off and unplug the power cord.

Dust collected around the power plug and outlet may cause fire.

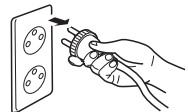

Ventilation

! CAUTION

- The product generates ozone gas during operation, but it will not be harmful to the human body.

If a bad smell of ozone is present in the following cases, ventilate the room.

- When the product is used in a poorly ventilated room
- When taking a lot of copies
- When using multiple products at the same time



Stability

! CAUTION

- Be sure to lock the caster stoppers.

In the case of an earthquake and so on, the product may slide, leading to a injury.



Inspection before Servicing

! CAUTION

- Before conducting an inspection, read all relevant documentation (service manual, technical notices, etc.) and proceed with the inspection following the prescribed procedure in safety clothes, using only the prescribed tools. Do not make any adjustment not described in the documentation.

If the prescribed procedure or tool is not used, the product may break and a risk of injury or fire exists.

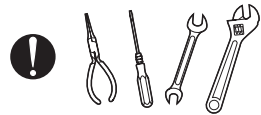

- Before conducting an inspection, be sure to disconnect the power plugs from the product and options.

When the power plug is inserted in the wall outlet, some units are still powered even if the POWER switch is turned OFF. A risk of electric shock exists.

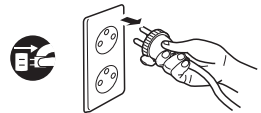

- The area around the fixing unit is hot.

You may get burnt.

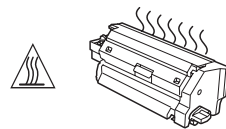

Inspection before Servicing

CAUTION

- Do not leave the machine unattended during transportation, installation, and inspection of the machine. If it is to be unavoidably left unattended, face protrusions toward the wall or take other necessary risk reducing action.



The user may stumble over a protrusion of the machine or be caught by a cable, falling to the floor or being injured.

Work Performed with the Product Powered On

WARNING

- Take every care when making adjustments or performing an operation check with the product powered.

If you make adjustments or perform an operation check with the external cover detached, you may touch live or high-voltage parts or you may be caught in moving gears or the timing belt, leading to a risk of injury.

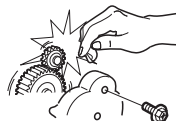

- Take every care when servicing with the external cover detached.

High-voltage exists around the drum unit. A risk of electric shock exists.



- If it is absolutely necessary to service the machine with the door open or external covers removed, always be attentive to the motion of the internal parts.

A normally protected part may cause unexpected hazards.



Safety Checkpoints

WARNING

- Check the exterior and frame for edges, burrs, and other damage.

The user or CE may be injured.



- Whenever mounting an option on the machine, be attentive to the motion of the fellow worker of the joint work.

The fellow worker may be injured with his or her finger or hand pinched between the machine and the option.



Safety Checkpoints

WARNING

- When mounting an option on the machine, be careful about the clearance between the machine and the option.

You may be injured with your finger or hand pinched between the machine and the option.



- When removing a part that secures a motor, gear, or other moving part, disassembling a unit, or reinstalling any of such parts and units, be careful about moving parts and use care not to drop any part or unit. During the service procedure, give sufficient support for any heavy unit.

You may be injured by a falling part or unit.



- Check the external covers and frame for possible sharp edges, burrs, and damage.

They can be a cause of injury during use or servicing.



- When accessing a hard-to-view or narrow spot, be careful about sharp edges and burrs of the frame and parts.

They may injure your hands or fingers.



- Do not allow any metal parts such as clips, staples, and screws to fall into the product.

They can short internal circuits and cause electric shock or fire.

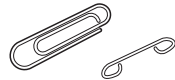

- Check wiring for squeezing and any other damage.

Current can leak, leading to a risk of electric shock or fire.



- Carefully remove all toner remnants and dust from electrical parts and electrode units such as a charging corona unit.

Current can leak, leading to a risk of product trouble or fire.



- Check high-voltage cables and sheaths for any damage.

Current can leak, leading to a risk of electric shock or fire.



- Check electrode units such as a charging corona unit for deterioration and sign of leakage.

Current can leak, leading to a risk of trouble or fire.



Safety Checkpoints

WARNING

- Before disassembling or adjusting the write unit (P/H unit) incorporating a laser, make sure that the power cord has been disconnected.

The laser light can enter your eye, leading to a risk of loss of eyesight.



- Do not remove the cover of the write unit. Do not supply power with the write unit shifted from the specified mounting position.

The laser light can enter your eye, leading to a risk of loss of eyesight.



- When replacing a lithium battery, replace it with a new lithium battery specified in the Parts Guide Manual. Dispose of the used lithium battery using the method specified by local authority.

Improper replacement can cause explosion.



- After replacing a part to which AC voltage is applied (e.g., optical lamp and fixing lamp), be sure to check the installation state.

A risk of fire exists.

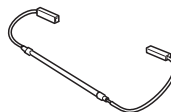

- Check the interlock switch and actuator for loosening and check whether the interlock functions properly.

If the interlock does not function, you may receive an electric shock or be injured when you insert your hand in the product (e.g., for clearing paper jam).

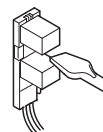

- Make sure the wiring cannot come into contact with sharp edges, burrs, or other pointed parts.

Current can leak, leading to a risk of electric shock or fire.



- Make sure that all screws, components, wiring, connectors, etc. that were removed for safety check and maintenance have been reinstalled in the original location. (Pay special attention to forgotten connectors, pinched cables, forgotten screws, etc.)

A risk of product trouble, electric shock, and fire exists.



Handling of Consumables

WARNING

- Toner and developer are not harmful substances, but care must be taken not to breathe excessive amounts or let the substances come into contact with eyes, etc. It may be stimulative.

If the substances get in the eye, rinse with plenty of water immediately. When symptoms are noticeable, consult a physician.



- Never throw the used cartridge and toner into fire.
You may be burned due to dust explosion.



Handling of Service Materials

CAUTION

- Unplug the power cord from the wall outlet.

Drum cleaner (isopropyl alcohol) and roller cleaner (acetone-based) are highly flammable and must be handled with care. A risk of fire exists.

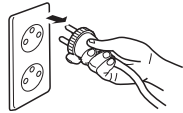

- Do not replace the cover or turn the product ON before any solvent remnants on the cleaned parts have fully evaporated.

A risk of fire exists.



- Use only a small amount of cleaner at a time and take care not to spill any liquid. If this happens, immediately wipe it off.

A risk of fire exists.



- When using any solvent, ventilate the room well.
Breathing large quantities of organic solvents can lead to discomfort.



[4] Laser Safety

- This is a digital machine certified as a Class 1 laser product. There is no possibility of danger from a laser, provided the machine is serviced according to the instruction in this manual.

4.1 Internal Laser Radiation

semiconductor laser	
Maximum power of the laser diode	7 mW
Maximum average radiation power (*)	5.3 μ W
Wavelength	770 - 800 nm

*at laser aperture of the Print Head Unit

- This product employs a Class 3B laser diode that emits an invisible laser beam. The laser diode and the scanning polygon mirror are incorporated in the print head unit.
- The print head unit is NOT A FIELD SERVICEABLE ITEM. Therefore, the print head unit should not be opened under any circumstances.

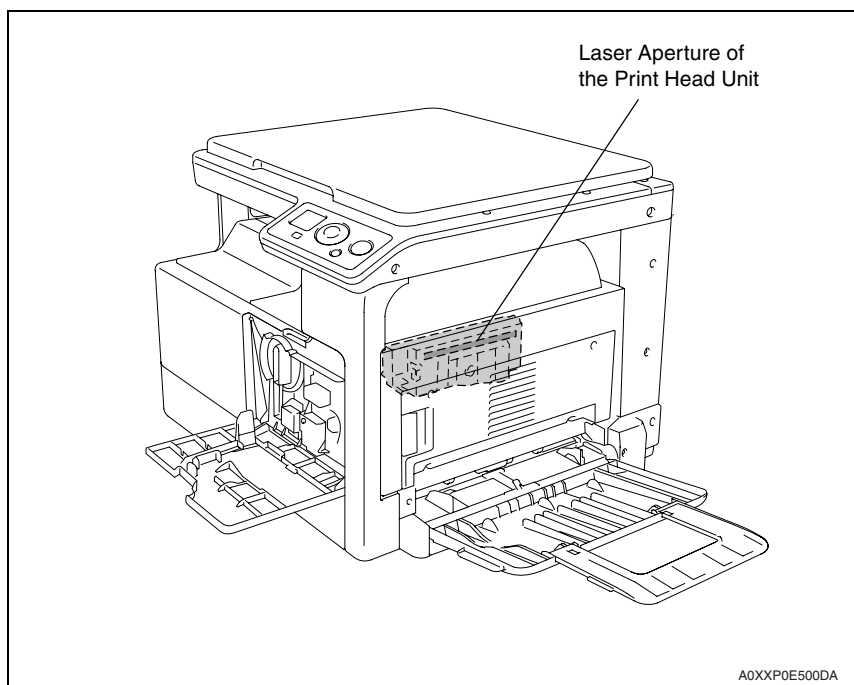

All Areas

CAUTION

- Use of controls, adjustments or performance of procedures other than those specified in this manual may result in hazardous radiation exposure.

semiconductor laser	
Maximum power of the laser diode	7 mW
Wavelength	770 - 800 nm

Denmark

ADVARSEL

- Usynlig laserstråling ved åbning, når sikkerhedsafbrydere er ude af funktion. Undgå udsættelse for stråling. Klasse 1 laser produkt der opfylder IEC60825-1 sikkerheds kravene.

halvlederlaser	
Laserdiodens højeste styrke	7 mW
bølgelængden	770 - 800 nm

Finland, Sweden

**LUOKAN 1 LASERLAITE
KLASS 1 LASER APPARAT****VAROITUS!**

- Laitteen käyttäminen muulla kuin tässä käyttöohjeessa mainitulla tavalla saattaa altistaa käyttäjän turvallisuusluokan 1 ylittävälle näkymättömälle laser-säteilylle.

puolijohdelaser	
Laserdiodin suurin teho	7 mW
aallonpituus	770 - 800 nm

WARNING!

- Om apparaten används på annat sätt än i denna bruksanvisning specificerats, kan användaren utsättas för osynlig laserstrålning, som överskrider gränsen för laserklass 1.

halvedarlaser	
Den maximala effekten för laserdioden	7 mW
våglängden	770 - 800 nm

VARO!

- Avattaessa ja suojalukitus ohitettaessa olet alttiina näkymättömälle laser-säteilylle. Älä katso säteeseen.

WARNING!

- Osynlig laserstråining när denna del är öppnad och spärren är urkopplad. Betrakta ej stråien.

Norway

ADVERSEL

- Dersom apparatet brukes på annen måte enn spesifisert i denne bruksanvisning, kan brukeren utsettes for usynlig laserstråling, som overskrider grensen for laser klass 1.

halvleder laser	
Maksimal effekt till laserdioder	7 mW
bølgelengde	770 - 800 nm

4.2 Laser Safety Label

- A laser safety label is attached to the inside of the machine as shown below.

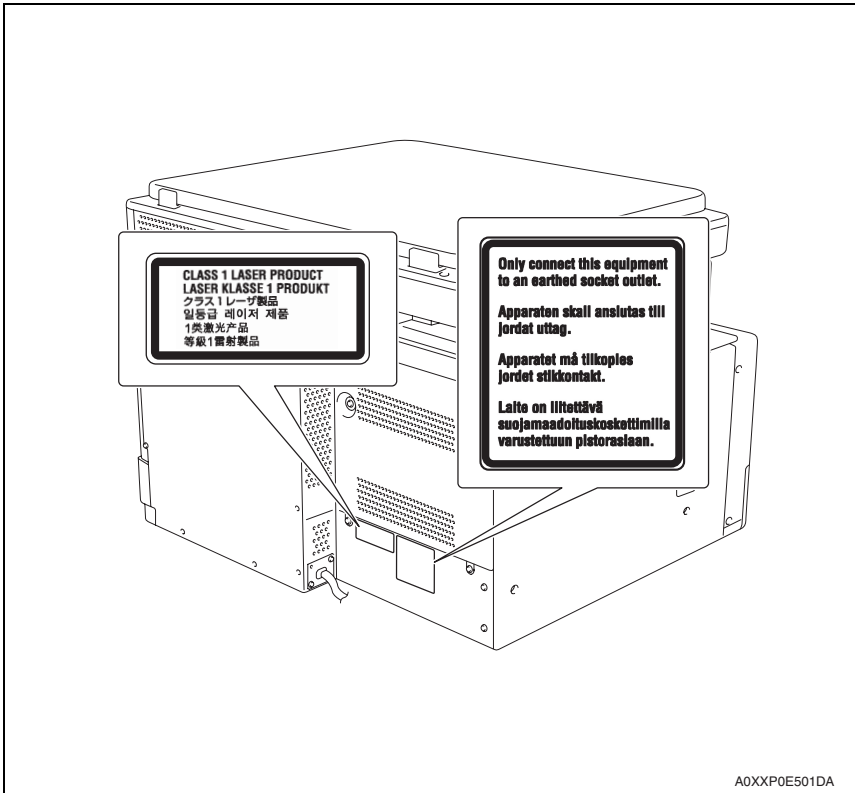

4.3 Laser Caution Label

- A laser caution label is attached to the outside of the machine as shown below.

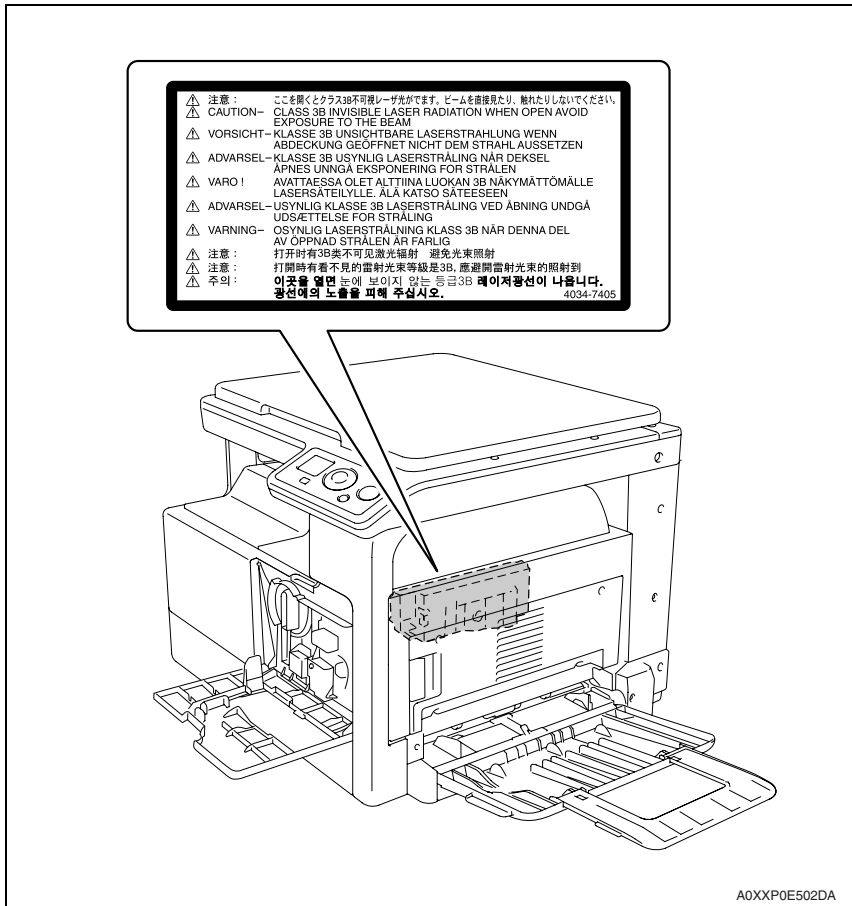

4.4 PRECAUTIONS FOR HANDLING THE LASER EQUIPMENT

- When laser protective goggles are to be used, select ones with a lens conforming to the above specifications.
- When a disassembly job needs to be performed in the laser beam path, such as when working around the printerhead and PC Drum, be sure first to turn the printer OFF.
- If the job requires that the printer be left ON, take off your watch and ring and wear laser protective goggles.
- A highly reflective tool can be dangerous if it is brought into the laser beam path. Use utmost care when handling tools on the user's premises.

WARNING INDICATIONS ON THE MACHINE

Caution labels shown below are attached in some areas on/in the machine.

When accessing these areas for maintenance, repair, or adjustment, special care should be taken to avoid burns and electric shock.

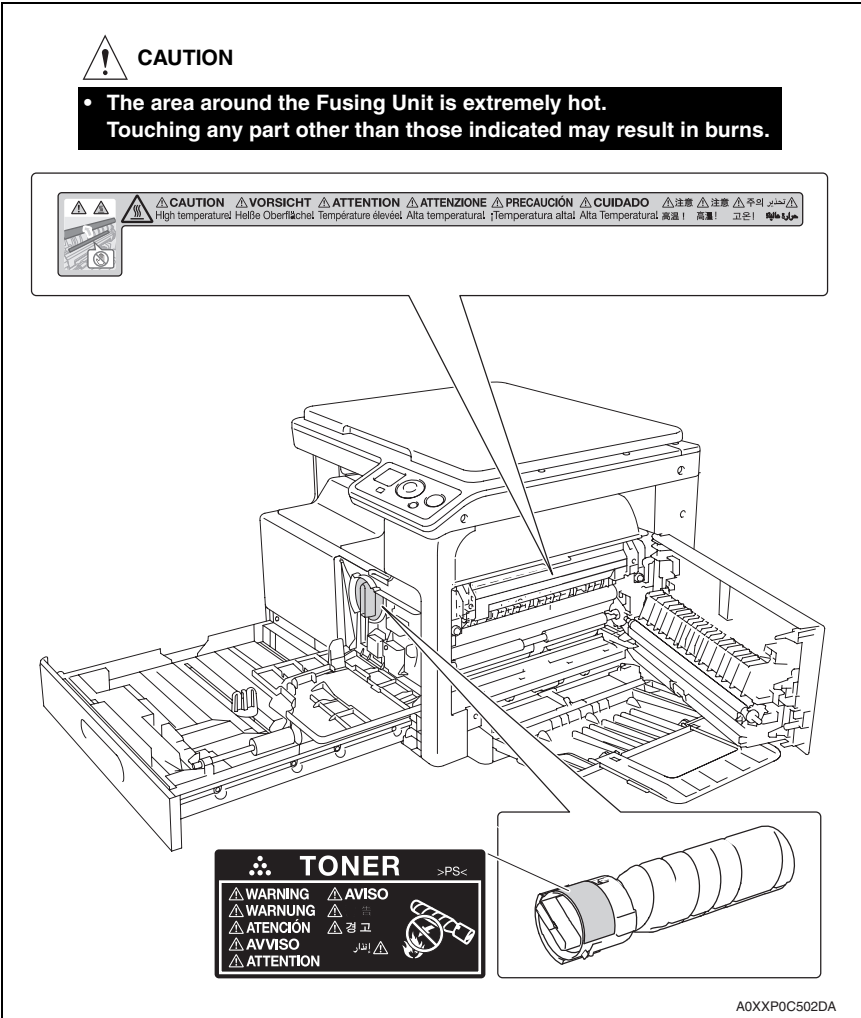

⚠ CAUTION:

- You may be burned or injured if you touch any area that you are advised by any caution label to keep yourself away from. Do not remove caution labels. And also, when the caution label is peeled off or soiled and cannot be seen clearly, replace it with a new caution label.

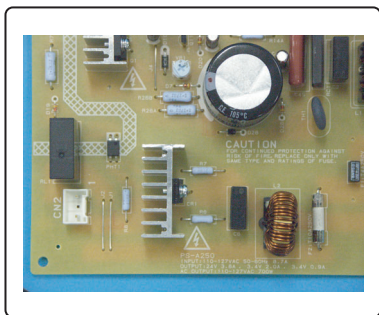

High voltage

- This area generates high voltage. Be careful not to touch here when the power is turned ON to avoid getting an electric shock.

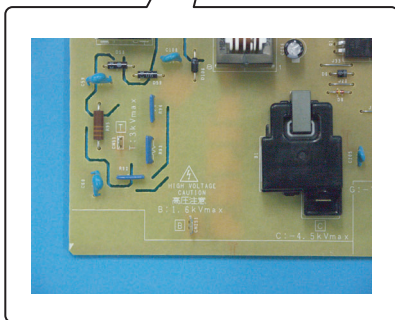
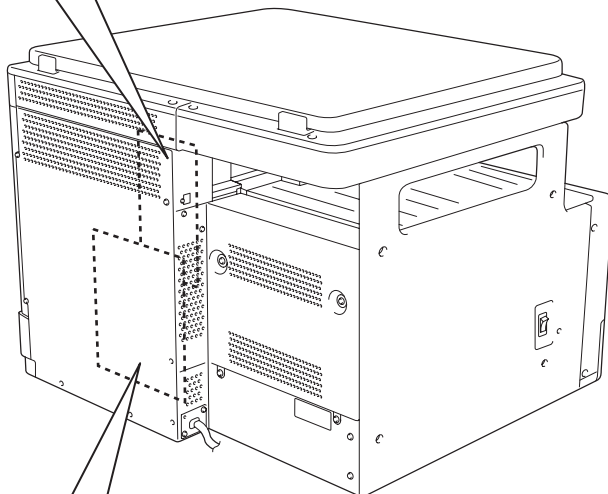

High voltage

- This area generates high voltage. Be careful not to touch here when the power is turned ON to avoid getting an electric shock.

A0XXP0E503DA

MEASURES TO TAKE IN CASE OF AN ACCIDENT

1. If an accident has occurred, the distributor who has been notified first must immediately take emergency measures to provide relief to affected persons and to prevent further damage.
2. If a report of a serious accident has been received from a customer, an on-site evaluation must be carried out quickly and KMBT must be notified.
3. To determine the cause of the accident, conditions and materials must be recorded through direct on-site checks, in accordance with instructions issued by KMBT.
4. For reports and measures concerning serious accidents, follow the regulations specified by every distributor.

Blank Page

Composition of the service manual

This service manual consists of Theory of Operation section and Field Service section to explain the main machine and its corresponding options.

Theory of Operation section gives, as information for the CE to get a full understanding of the product, a rough outline of the object and role of each function, the relationship between the electrical system and the mechanical system, and the timing of operation of each part.

Field Service section gives, as information required by the CE at the site (or at the customer's premise), a rough outline of the service schedule and its details, maintenance steps, the object and role of each adjustment, error codes and supplementary information.

The basic configuration of each section is as follows. However some options may not be applied to the following configuration.

<Theory of Operation section>

OUTLINE:	Explanation of system configuration, product specifications, unit configuration, and paper path
COMPOSITION/OPERATION:	Explanation of configuration of each unit, operating system, and control system

<Field service section>

OUTLINE:	Explanation of system configuration, and product specifications
MAINTENANCE:	Explanation of service schedule, maintenance steps, service tools, removal/reinstallation methods of major parts, and firmware version up method etc.
ADJUSTMENT/SETTING:	Explanation of utility mode, service mode, and mechanical adjustment etc.
TROUBLESHOOTING:	Explanation of lists of jam codes and error codes, and their countermeasures etc.
APPENDIX:	Parts layout drawings, connector layout drawings, timing chart, overall layout drawing are attached.

Notation of the service manual

A. Product name

In this manual, each of the products is described as follows:

- | | |
|-------------------------------|------------------------------|
| (1) bizhub 164 | Main body |
| (2) Microsoft Windows NT 4.0: | Windows NT 4.0 or Windows NT |
| Microsoft Windows 2000: | Windows 2000 |
| Microsoft Windows XP: | Windows XP |
| Microsoft Windows Vista: | Windows Vista |
| Microsoft Windows 7: | Windows 7 |

When the description is made in combination of the OS's mentioned above:

Windows NT 4.0/2000

Windows NT/2000/XP/Vista/7

B. Brand name

The company names and product names mentioned in this manual are the brand name or the registered trademark of each company.

C. Feeding direction

- When the long side of the paper is parallel with the feeding direction, it is called short edge feeding. The feeding direction which is perpendicular to the short edge feeding is called the long edge feeding.
- Short edge feeding will be identified with [S (abbreviation for Short edge feeding)] on the paper size. No specific notation is added for the long edge feeding.

When the size has only the short edge feeding with no long edge feeding, [S] will not be added to the paper size.

<Sample notation>

Paper size	Feeding direction	Notation
A4	Long edge feeding	A4
	Short edge feeding	A4S
A3	Short edge feeding	A3



KONICA MINOLTA

SERVICE MANUAL

THEORY OF OPERATION

bizhub 164





Revision history

After publication of this service manual, the parts and mechanism may be subject to change for improvement of their performance.

Therefore, the descriptions given in this service manual may not coincide with the actual machine.

When any change has been made to the descriptions in the service manual, a revised version will be issued with a revision mark added as required.

Revision mark:

- To indicate clearly a section revised, show  to the left of the revised section.
A number within  represents the number of times the revision has been made.
- To indicate clearly a section revised, show  in the lower outside section of the corresponding page.
A number within  represents the number of times the revision has been made.

NOTE

Revision marks shown in a page are restricted only to the latest ones with the old ones deleted.

- When a page revised in Ver. 2.0 has been changed in Ver. 3.0:
The revision marks for Ver. 3.0 only are shown with those for Ver. 2.0 deleted.
- When a page revised in Ver. 2.0 has not been changed in Ver. 3.0:
The revision marks for Ver. 2.0 are left as they are.

2010/04	1.1	—	Issue of the first edition
2010/03	1.0	—	Issue of the draft edition
Date	Service manual Ver.	Revision mark	Descriptions of revision

CONTENTS

bizhub 164 main body

OUTLINE

1.	SYSTEM CONFIGURATION.....	1
2.	PRODUCT SPECIFICATIONS.....	2
2.1	Type.....	2
2.2	Functions.....	2
2.3	Paper.....	3
2.4	Materials.....	3
2.5	Print volume.....	4
2.6	Machine specifications.....	4
2.7	Operating environment.....	4
2.8	Print function.....	5
2.9	Scan function.....	6
3.	CROSS SECTIONAL VIEW.....	7
4.	PAPER PATH.....	8

COMPOSITION/OPERATION

5.	OVERALL CONFIGURATION.....	9
5.1	Control Block Diagram.....	9
5.2	Image creation process.....	10
5.3	Timing chart at print start.....	11
5.3.1	Process speed.....	11
6.	INTERFACE SECTION.....	12
6.1	Configuration.....	12
7.	SCANNER SECTION.....	13
7.1	Configuration.....	13
7.2	Drive.....	14
7.3	Operation.....	15
7.3.1	Control when the Start key is pressed.....	15
8.	WRITING SECTION.....	16
8.1	Configuration.....	16
8.2	Operation.....	17
8.2.1	Overview.....	17
8.2.2	Laser emission area.....	18
9.	TONER SUPPLY SECTION.....	19
9.1	Configuration.....	19

9.2	Drive	19
9.3	Operation.....	20
9.3.1	Toner Replenishing Mechanism.....	20
9.3.2	Toner Replenishing Control	21
9.3.3	T/C Recovery Mode.....	21
9.3.4	Detection of toner empty condition	22
10.	IMAGING UNIT SECTION	23
10.1	Configuration	23
10.2	Operation.....	23
10.2.1	Imaging unit life detection	23
11.	IMAGING UNIT SECTION (Drum).....	24
11.1	Configuration	24
11.2	Drive	25
11.3	Operation.....	25
11.3.1	Drum drive	25
12.	IMAGING UNIT SECTION (charge corona).....	26
12.1	Configuration	26
12.2	Operation.....	27
13.	IMAGING UNIT SECTION (developing).....	28
13.1	Configuration	28
13.2	Drive	29
13.3	Operation.....	30
13.3.1	Toner flow	30
13.3.2	Developing Bias	31
13.3.3	TCR Sensor Automatic Adjustment	31
14.	TRANSFER/SEPARATION SECTION	32
14.1	Configuration	32
14.2	Drive	33
14.3	Operation.....	33
14.3.1	Transfer voltage output control.....	33
14.3.2	Transfer roller cleaning control.....	33
14.3.3	Paper Separation control	34
15.	TONER COLLECTION SECTION.....	35
15.1	Configuration	35
15.2	Drive	36
15.3	Operation.....	37
15.3.1	Toner collecting path.....	37
16.	PAPER FEED SECTION (Tray1).....	38
16.1	Configuration	38

16.2	Drive	39
16.3	Operation	40
16.3.1	Up/down control	40
16.3.2	Paper feed control	41
16.3.3	Paper size detection control	41
16.3.4	Remaining paper level detection control	42
17.	MULTI BYPASS SECTION (MB-503)	43
17.1	Configuration	43
17.2	Drive	44
17.3	Operation	45
17.3.1	Up/down control	45
17.3.2	Paper feed control	46
17.3.3	Remaining paper level detection control	47
18.	REGISTRATION SECTION	48
18.1	Configuration	48
18.2	Drive	49
18.3	Operation	50
18.3.1	Registration control	50
19.	FUSING SECTION	51
19.1	Configuration	51
19.2	Drive	52
19.3	Operation	52
19.3.1	Fusing speed correction	52
19.3.2	Fusing pressure control	52
19.3.3	Fusing temperature control	53
19.3.4	Protection from abnormally high temperature	55
19.3.5	PPM Control	55
19.3.6	Control for preventing roller edge temperature from rising	55
19.3.7	New article detection	56
20.	PAPER EXIT SECTION	57
20.1	Configuration	57
20.2	Drive	58
20.3	Operation	58
20.3.1	Conveyance control	58
21.	IMAGE STABILIZATION CONTROL	59
21.1	Configuration	59
22.	POWER SUPPLY SECTION	60
22.1	When the main power switch is turned ON	60
22.1.1	Configuration	60

22.1.2	Operation.....	60
23.	FAN CONTROL.....	61
23.1	Configuration.....	61
23.2	Operation.....	61
23.2.1	Function.....	61
23.2.2	Fan control.....	61

OUTLINE

1. SYSTEM CONFIGURATION

1/2 System front view

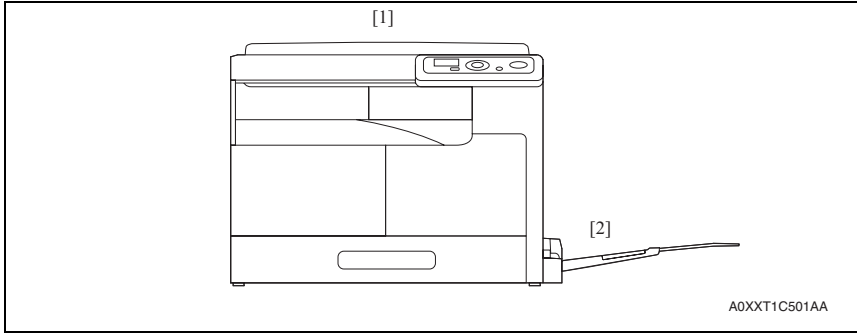

[1] bizhub 164

[2] Multi bypass tray (MB-503)

2. PRODUCT SPECIFICATIONS

2.1 Type

Type	Scanner/printer integrated desktop type
Scanning density	600 x 600 dpi
Platen	Stationary
Original scanning	CIS module optical scanning system
Scanning light source	LED
Printing process	Laser electrostatic printing system
PC drum type	OPC drum: 9ST
Paper feeding system	Tray 1: Separator pad system Multi bypass tray: Small roller separation system with torque limiter
Exposure system	LD exposing system/polygon mirror scan system
Exposure density	600 x 600 dpi
Developing system	Dry 2 components developing method, HMT developing system
Charging system	DC comb electrode scorotron system
Neutralizing system	Non-erase
Image transfer system	Roller image transfer system
Paper separating system	Combination of curvature, separating claws system
Fusing system	Roller fusing system
Heating system	Halogen lamp

2.2 Functions

Types of original	Sheets, books, and three-dimensional objects	
Max. original size	A3 or 11 × 17	
Max. original weight	2 kg	
Multiple copies	1 to 99	
Warming-up time	220 - 240 V: 29 sec. or less 110 V/120 - 127 V: 30 sec. or less (when the power switch is turned ON from a stabilized state at ambient temperature of 23° C/73.4° F and rated source voltage)	
Image loss	Leading edge: 4 mm (3/16 inch), trailing edge: 4 mm (3/16 inch), Rear edge: 4 mm (3/16 inch), front edge: 4 mm (3/16 inch)	
First copy time (A4, 8 1/2 x 11)	8 sec. or less (Values in conditions of paper fed from tray 1 at a room temperature of 23°C and with a rated power source)	
Processing speed	77 mm/s	
Copying/printing speed for multi-copy cycle (A4, 8 1/2 x 11)	bizhub 164	16 sheets/min. (Plain paper) 7 sheets/min. (Card1/2)

Fixed zoom ratios	Europe, china	Full size: x 1.00 Reduction: x 0.50, x 0.70, x 0.81 Enlargement: x 1.15, x 1.41, x 2.00
	Latin america areas for inch	Full size: x 1.00 Reduction: x 0.50, x 0.64, x 0.78 Enlargement: x 1.21, x 1.29, x 2.000
	Latin america area for metric	Full size: x 1.00 Reduction: x 0.500, x 0.70, x 0.78 Enlargement: x 1.15, x 1.41, x 2.000
Variable zoom ratios	×0.50 to ×2.00 (in 0.001 increments)	
Paper size used	Tray 1	A3 to A5S, Letter, LedgerS, 11 x 14, LegalS, Invoice, 8K, 16K, FLS
	Multi bypass tray	
Copy exit tray capacity	250 sheets	

2.3 Paper

		Tray 1	Multi bypass tray
Type	Plain paper (64 to 90 g/m ² / 17 to 24 lb)	○ (250 sheets)	○ (100 sheets)
	Card 1 (91 to 120 g/m ² / 24.25 to 31.75 lb)	○ (20 sheets)	○ (20 sheets)
	Card 2 (121 to 157 g/m ² / 32.25 to 41.75 lb)	○ (20 sheets)	○ (20 sheets)
	OHP film	-	-
	Postcards	-	-
	Labels	-	-
	Envelopes	-	-
Size	Width	90 to 297 mm / 3 ⁹ / ₁₆ to 11 ¹¹ / ₁₆ inch	
	Length	139.7 to 431.8 mm / 5 ¹ / ₂ to 17 inch	

2.4 Materials

Parts name	Number of prints	Type name
Toner bottle	5,000 prints *1	TN117
	11,000 prints *1	TN116
Developer	55,000 prints *1	DV116
Drum	55,000 prints *1	DR114

*1: Specification value

2.5 Print volume

A. bizhub 164

China	Average	2,300 prints/month
	Maximum	12,000 prints/month
Non- China	Average	1,700 prints/month
	Maximum	12,000 prints/month

2.6 Machine specifications

Power requirements	Voltage	AC110 V, AC120-127V, AC220-240V	
	Current	110 V	7 A
		120 V	6 A
		127 V	6 A
		230 V	3.5 A
Frequency	50/60 Hz		
Max power consumption	800 W		
Dimensions	570 mm (W) x 531 mm (D) x 419mm (H) *1 22.4 inch (W) x 20.9 inch (D) x 16.5 inch (H) *1		
Space requirements	928 mm (W) x 531 mm (D) *2 36.5 inch (W) x 20.9 inch (D) *2		
Weight	Approx. 23.5 kg /51.8 lb (without toner bottle and developer)		

*1: Height up to the original glass.

*2: When the multi bypass tray MB-503 is used.

2.7 Operating environment

Temperature	10 to 30° C / 50 to 86° F (with a fluctuation of 10° C / 18° F or less per hour)
Humidity	15 to 85% (Relative humidity with a fluctuation of 10%/h)

2.8 Print function

Type	Built-in printer controller
RAM	32 MB (shared with the copier)
Interface	USB2.0/1.1
Printer language	GDI
Print resolution	600 x 600 dpi
Printer fonts	Windows font
Supported OS for printer driver	<p>Windows 2000 Professional (SP4 or later)</p> <p>Windows 2000 Server (SP3 or later)</p> <p>Windows XP Home Edition (SP1 or later)</p> <p>Windows XP Professional (SP1 or later)</p> <p>Windows Server 2003, Standard Edition (SP1 or later)</p> <p>Windows Server 2003, Enterprise Edition (SP1 or later)</p> <p>Windows Server 2003 R2, Standard Edition</p> <p>Windows Server 2003 R2, Enterprise Edition</p> <p>Windows XP Professional x64 Edition</p> <p>Windows Server 2003, Standard x64 Edition</p> <p>Windows Server 2003, Enterprise x64 Edition</p> <p>Windows Server 2003 R2, Standard x64 Edition</p> <p>Windows Server 2003 R2, Enterprise x64 Edition</p> <p>Windows Vista Business *</p> <p>Windows Vista Enterprise *</p> <p>Windows Vista Home Basic *</p> <p>Windows Vista Home Premium *</p> <p>Windows Vista Ultimate *</p> <p>Windows Server 2008 Standard *</p> <p>Windows Server 2008 Enterprise *</p> <p>Windows 7 Home Premium/Professional/Ultimate *</p> <p>* 32 bits (x86)/64 bits (x64) environment are supported</p>

2.9 Scan function

Scanner	Scannable range	Same as the copier
	Scanning resolution	150/300/600 dpi
TWAIN	Driver	TWAIN Driver
	Supported OS	Windows 2000 Professional (SP4 or later) Windows 2000 Server (SP3 or later) Windows XP Home Edition (SP1 or later) Windows XP Professional (SP1 or later) Windows Server 2003, Standard Edition (SP1 or later) Windows Server 2003, Enterprise Edition (SP1 or later) Windows Server 2003 R2, Standard Edition Windows Server 2003 R2, Enterprise Edition Windows XP Professional x64 Edition Windows Server 2003, Standard x64 Edition Windows Server 2003, Enterprise x64 Edition Windows Server 2003 R2, Standard x64 Edition Windows Server 2003 R2, Enterprise x64 Edition Windows Vista Business * Windows Vista Enterprise * Windows Vista Home Basic * Windows Vista Home Premium * Windows Vista Ultimate * Windows Server 2008 Standard * Windows Server 2008 Enterprise * Windows 7 Home Premium/Professional/Ultimate * * 32 bits (x86)/64 bits (x64) environment are supported

3. CROSS SECTIONAL VIEW

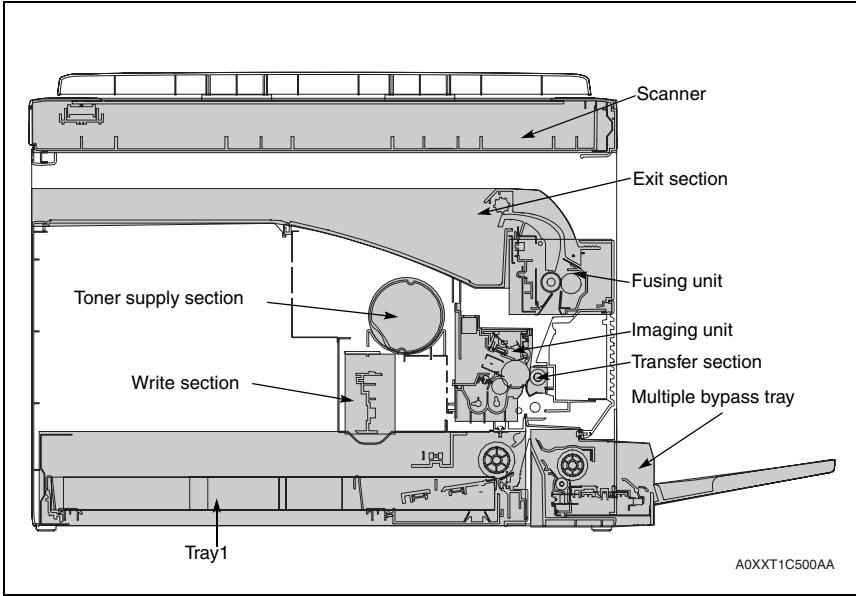

bizhub 164

OUTLINE

4. PAPER PATH

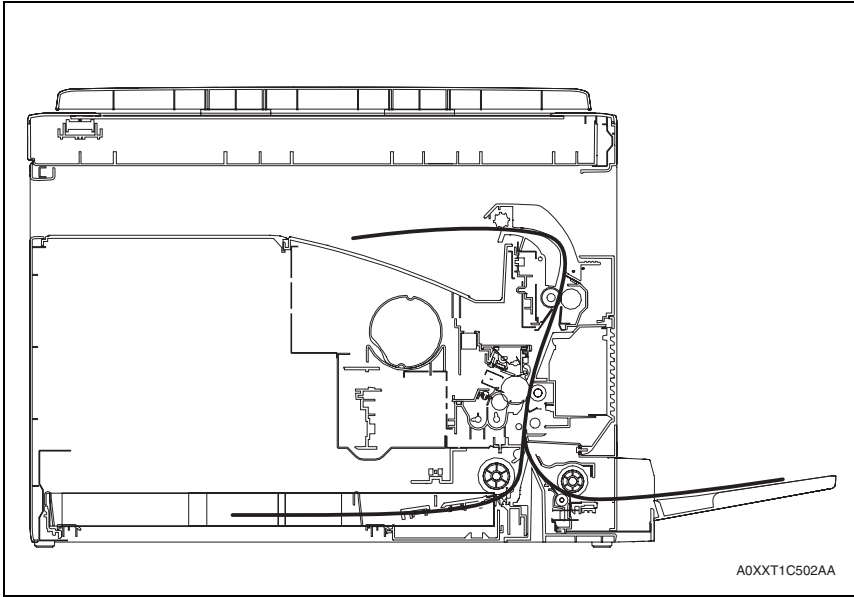

COMPOSITION/OPERATION

5. OVERALL CONFIGURATION

5.1 Control Block Diagram

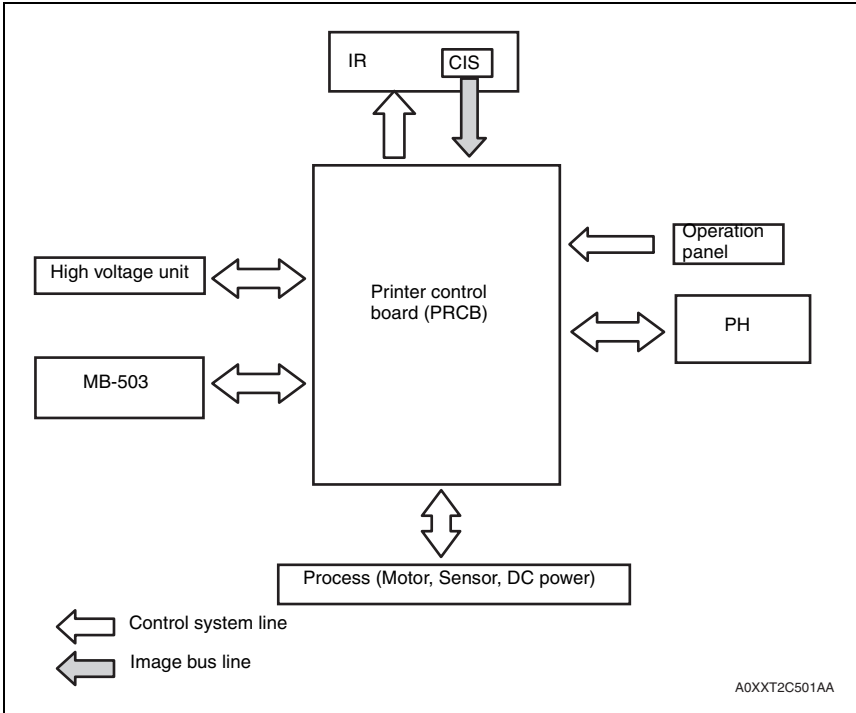

bizhub 164

COMPOSITION/
OPERATION

5.2 Image creation process

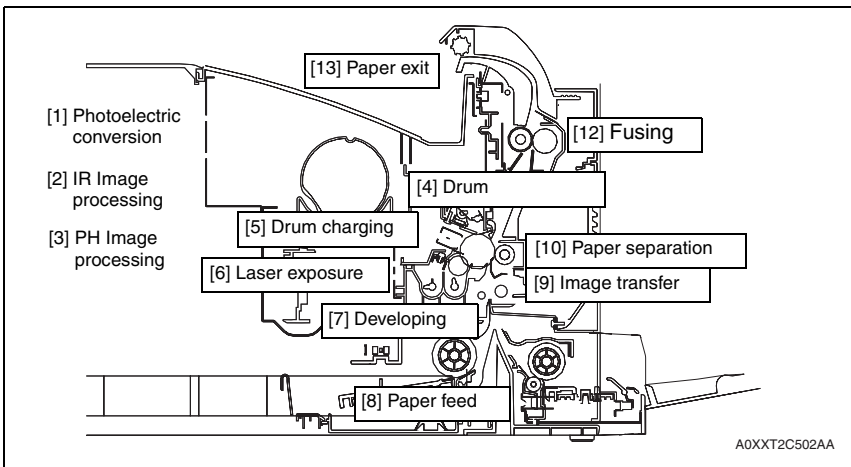

A0XXT2C502AA

[1]	Photoelectric conversion	<ul style="list-style-type: none"> A CIS sensor is used to convert the image data represented by light reflected off the original to a corresponding electric signal which, in turn, is output to the IR image processing section.
[2]	IR Image processing	<ul style="list-style-type: none"> The analog electric signal is converted to an 8-bit digital image signal (A/D conversion) which, in turn, goes through appropriate corrections before being output to the PH image processing section.
[3]	PH Image processing	<ul style="list-style-type: none"> After going through corrections, the digital image signal is converted to a corresponding electric signal (D/A conversion), with which the laser is turned ON or OFF as necessary.
[4]	Drum	<ul style="list-style-type: none"> Made up of an aluminum pipe coated with a photoconductive layer, on which an electrostatic latent image is formed.
[5]	Drum charging	<ul style="list-style-type: none"> A uniform negative DC charge is deposited across the entire surface of the drum.
[6]	Laser exposure	<ul style="list-style-type: none"> The laser beam strikes the surface of the drum, forming an electrostatic latent image.
[7]	Developing	<ul style="list-style-type: none"> Toner negatively charged in the developer mixing chamber is attracted onto the electrostatic latent image changing it to a visible, developed image. A developing bias (Vb) is applied to the developing roller to prevent toner from being attracted onto those areas of the drum which correspond to the background areas of the original.
[8]	Paper feed	<ul style="list-style-type: none"> Paper is supplied from the paper feed tray.
[9]	Image transfer	<ul style="list-style-type: none"> A DC positive charge is applied to the image transfer roller to transfer the visible image on the surface of the drum onto the paper.
[10]	Paper separation	<ul style="list-style-type: none"> The drum paper separator fingers remove paper from the surface of the drum. The charge neutralizing plate neutralizes any charge left on the paper.
[11]	Cleaning	<ul style="list-style-type: none"> Residual toner on the surface of the drum is scraped off. The toner is then recycled back to the developing unit.
[12]	Fusing	<ul style="list-style-type: none"> The developed image is permanently fused to the paper by the combination of heat and pressure applied by the fusing roller.
[13]	Paper exit	<ul style="list-style-type: none"> The paper is fed out onto the exit tray.

bizhub 164

COMPOSITION/
OPERATION

5.3 Timing chart at print start

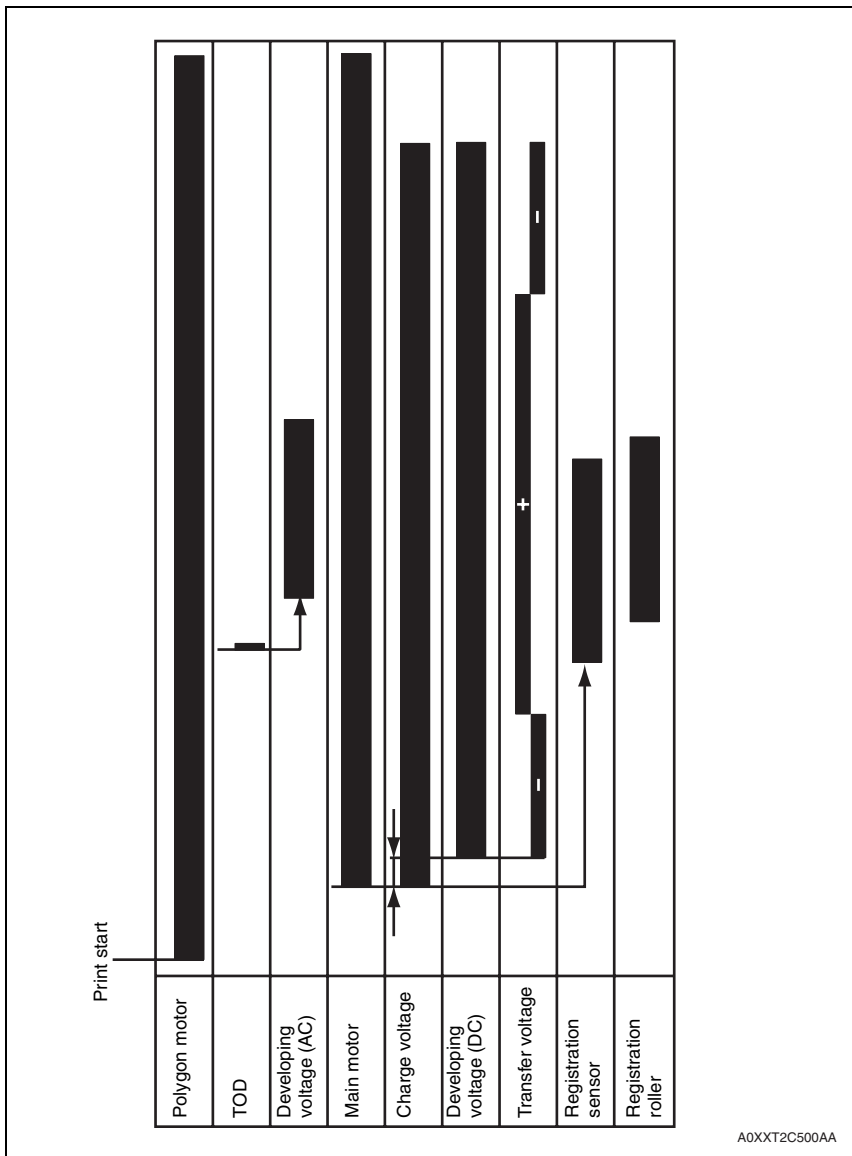

5.3.1 Process speed

- The main body has a process speed of 77 mm/s.
- The process speed is not changed according to the size or type of the paper. Instead, the main body controls the intervals between sheets of paper (paper transport timing). For details, see “FUSING SECTION / PPM control”.

6. INTERFACE SECTION

6.1 Configuration

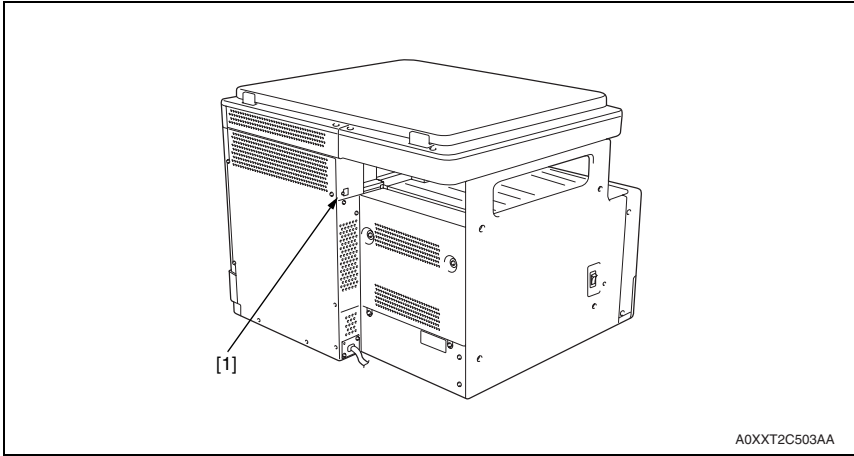

No	Type	Use
[1]	USB Port (Type A) USB2.0/1.1	For connection between pc and main body

7. SCANNER SECTION

7.1 Configuration



A0XXT2C546AA

CIS module (CIS)

Scanner motor (M4)

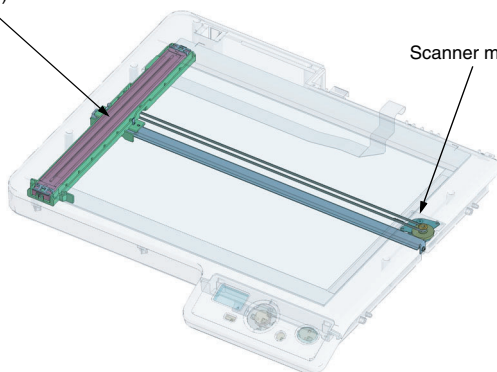

A0XXT2C543AA

7.2 Drive

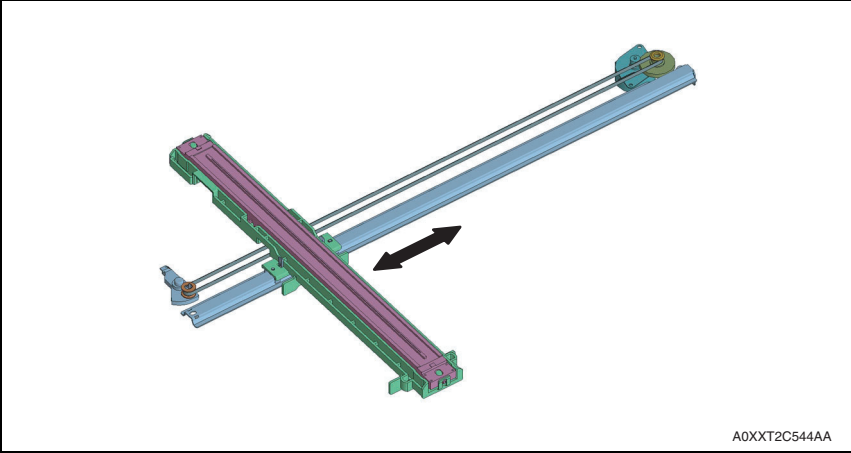

bizhub 164

COMPOSITION/
OPERATION

7.3 Operation

7.3.1 Control when the Start key is pressed

1. If the start key is pressed, the scanner starts a shading sequence from the standby position to shading end position.
If any key but start key is pressed, the scanner starts a pre-shading sequence from the standby position to shading end position.
2. After the pre-shading sequence, the scanner is stopped at the return position. After the lapse of 30 seconds thereafter, the scanner moves to the standby position.
3. If the start key is pressed in step 1 above or during a period of 30 seconds after the pre-shading sequence, the scanner starts a scan motion immediately.
4. After the scan motion has been finished, the scanner makes a return motion to move back to the return position.
5. After the completion of the return motion, the scanner starts a home position detection sequence.
6. After the home position is detected, the scanner moves to, and stops at, the standby position.

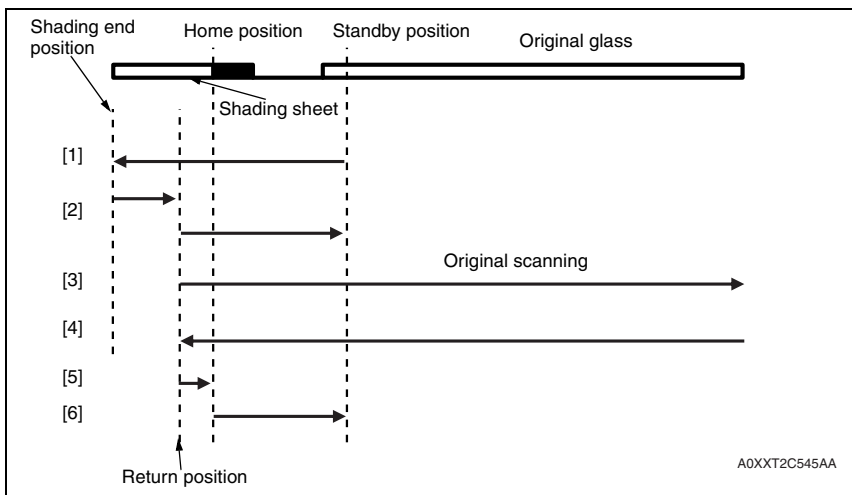

bizhub 164

COMPOSITION/
OPERATION

8. WRITING SECTION

8.1 Configuration

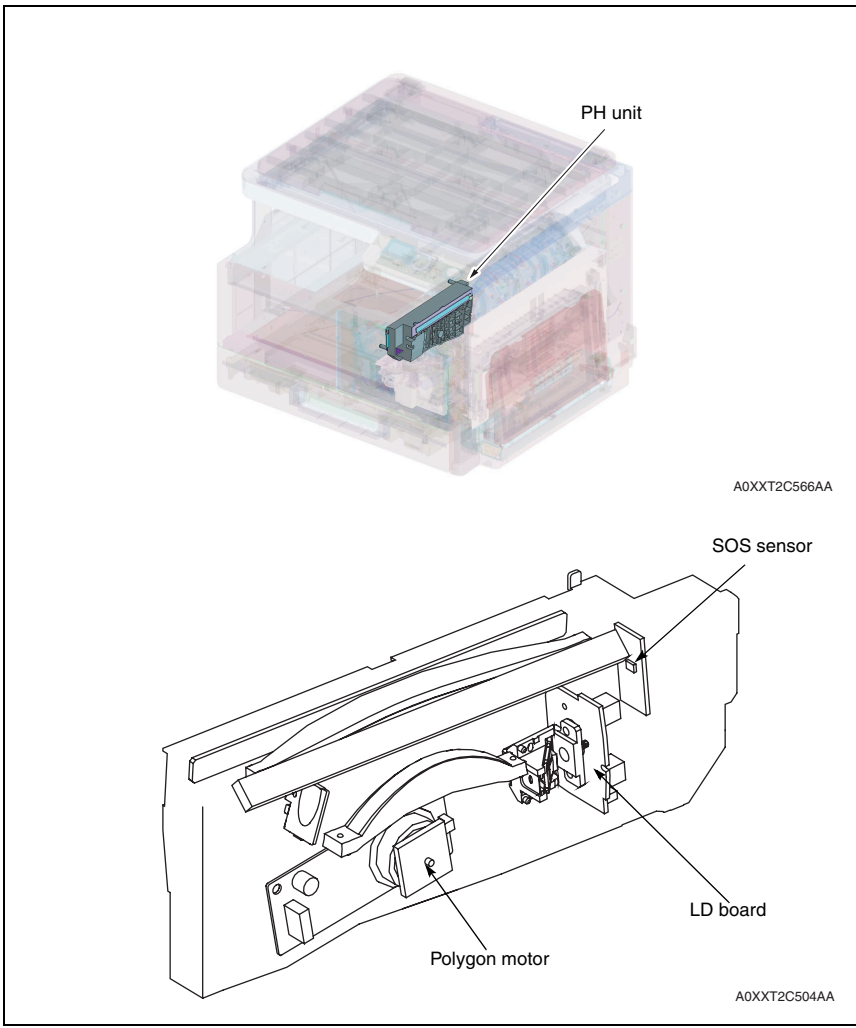

bizhub 164

COMPOSITION/
OPERATION

8.2 Operation

8.2.1 Overview

- When a laser beam strikes the polygon mirror, light reflected off the Polygon Mirror is directed at the drum by way of the lens and return mirror.
- The polygon mirror has four faces, being turned at high speeds by the polygon motor.
- The sos mirror and sos sensor keep constant the timing, at which emission of a laser beam is started for each main scanning line.

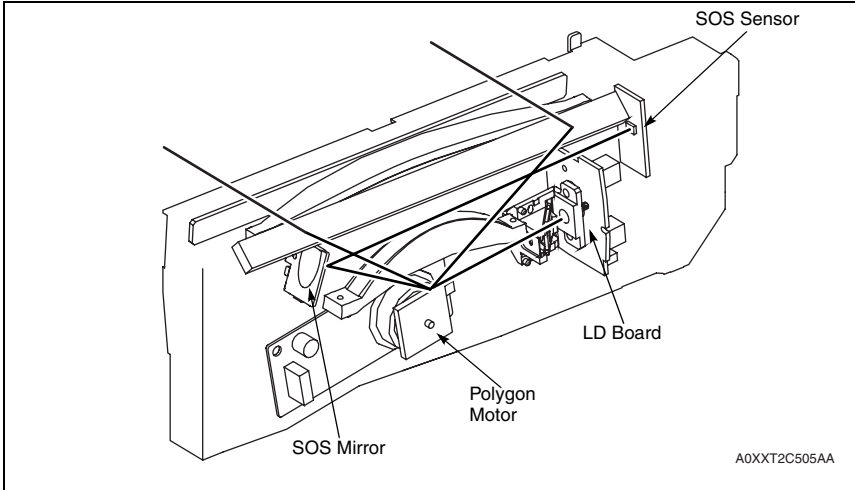

8.2.2 Laser emission area

A. Main scan direction (CD)

- The print start position in the CD direction is determined by the CD print start signal (HSYNC) that is output from the printer control board and the width of the media.
- The laser emission area is determined by the media size. However, there is a 4.0 mm wide void area on both the both edges of the media.

B. Sub scan direction (FD)

- The print start position in the FD direction is determined by the FD print start signal (TOD) that is output from the printer control board and the length of the media.
- The laser emission area is determined by the media size. However, there is a 4.0 mm wide void area on both the leading and trailing edges of the media.

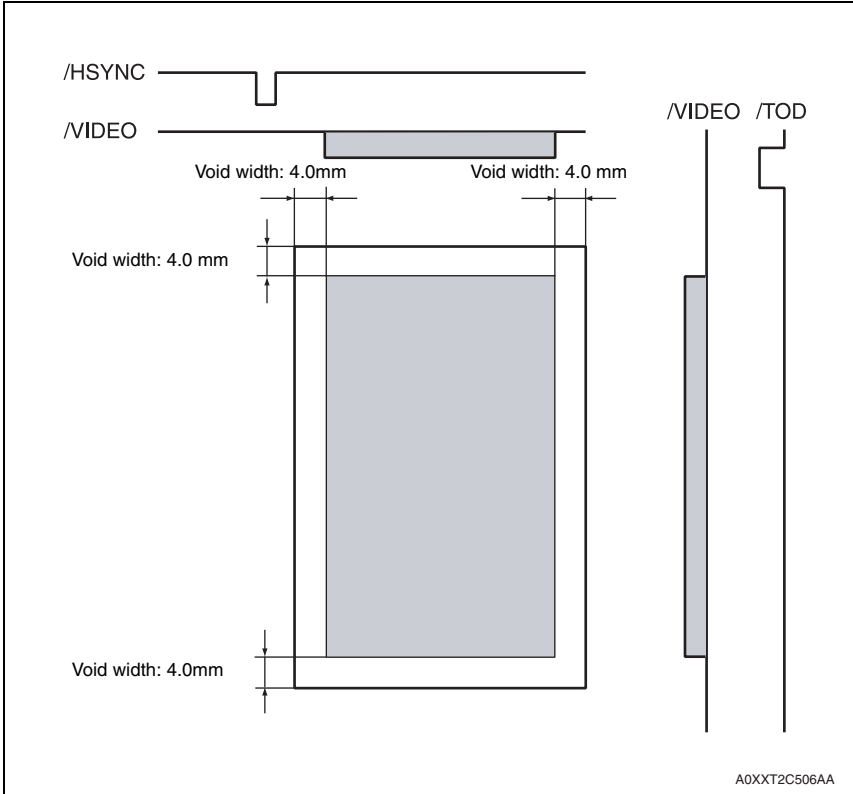

bizhub 164

COMPOSITION/
OPERATION

9. TONER SUPPLY SECTION

9.1 Configuration

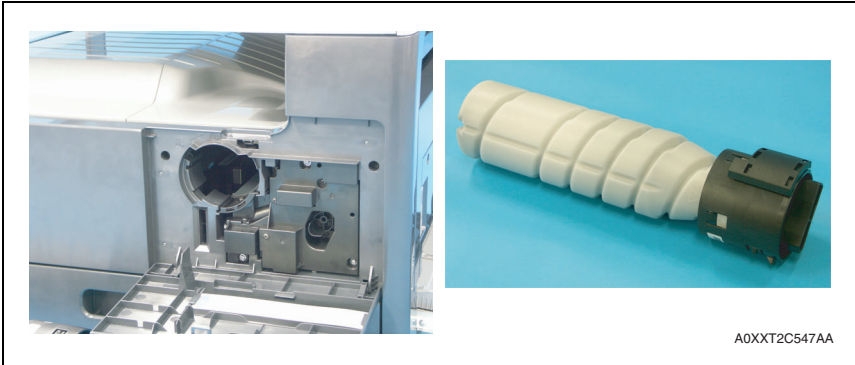

9.2 Drive

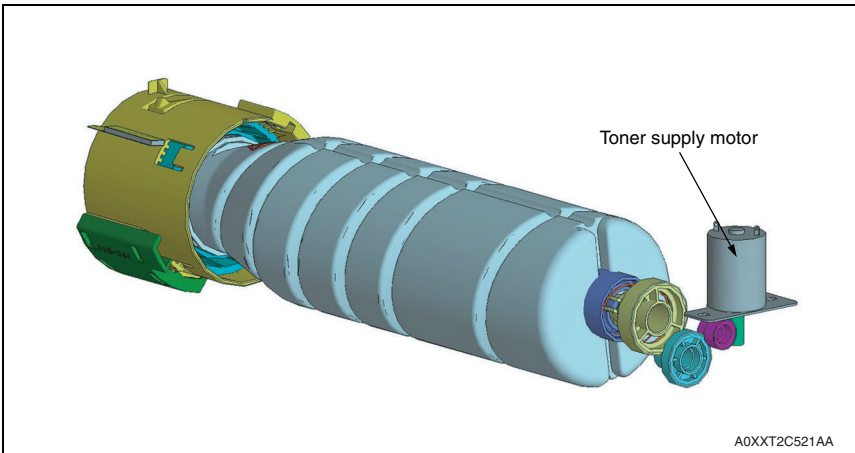

9.3 Operation

9.3.1 Toner Replenishing Mechanism

- Toner is supplied from the toner bottle to the developer mixing chamber.
 1. The toner replenishing motor (M2) turns the coupling, which turns the toner bottle.
 2. To regulate the amount of toner supplied from the toner bottle, there is a metering chamber provided in the outer race of the coupling.
 3. When the toner bottle turns, toner in the metering chamber drops.
 4. When the toner bottle is turned again, the supply door is opened by the weight of toner in the metering chamber and the toner drops.
 5. Toner from the metering chamber is conveyed by the toner conveying screw into the developer mixing chamber.
 6. The toner conveying screw is turned by the toner replenishing motor (M2).

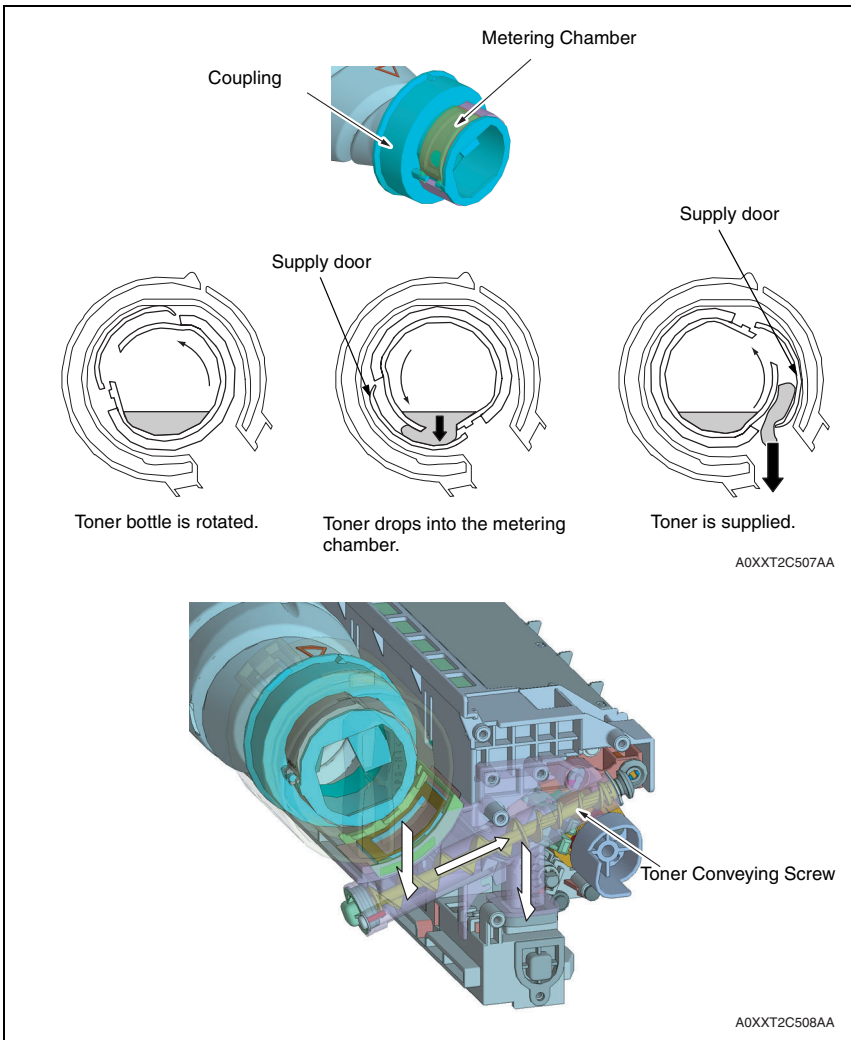

bizhub 164

COMPOSITION/
OPERATION

9.3.2 Toner Replenishing Control

- The amount of toner consumed for the image (number of dots) is calculated for each print during printing. The calculated value is compared with the T/C ratio read by the TCR sensor. The main body thereby determines whether to replenish toner or not.
- If toner is to be replenished, the toner bottle is rotated one complete turn.
- The T/C ratio is calculated after the replenishing sequence. If the recalculated T/C ratio is equal to, or more than, a predetermined value in%, the replenishing sequence is terminated. If the ratio is less than the predetermined value, toner replenishing sequence is carried out again.

9.3.3 T/C Recovery Mode

- If the T/C ratio is low, the main body forcibly prohibits the initiation of a new print cycle and recovers the required T/C ratio level.
- Two patterns of control are performed according to the timing at which the T/C recovery sequence is performed.

A. T/C recovery sequence A

- This sequence is executed when a toner empty condition is detected during a print cycle.
- As soon as a toner empty condition is detected, the print cycle is temporarily interrupted and toner replenishing sequence is carried out.

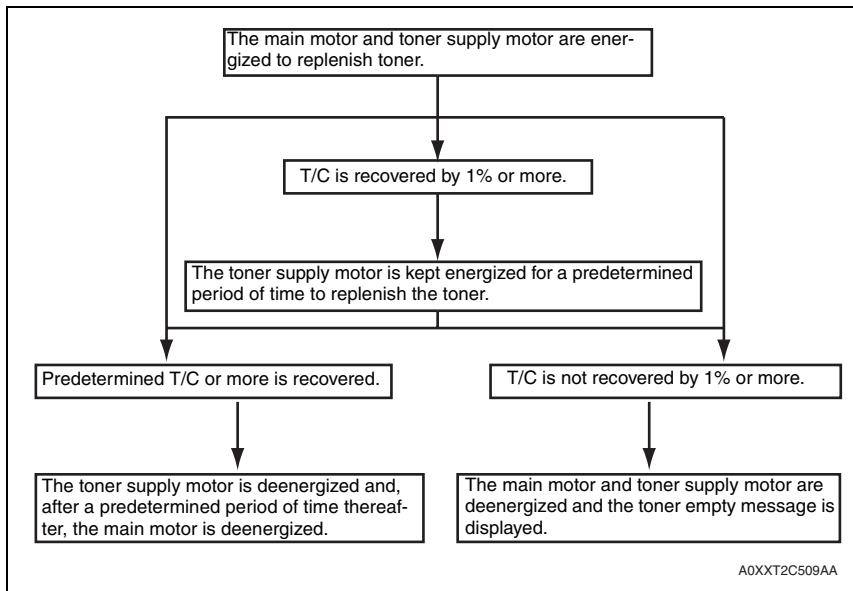

A0XXT2C509AA

B. T/C recovery sequence B

- This sequence is executed when:
 The front cover or right door is opened and closed in a toner empty condition.
 Power is turned OFF and ON in a toner empty condition.
 A Toner Supply command is issued.

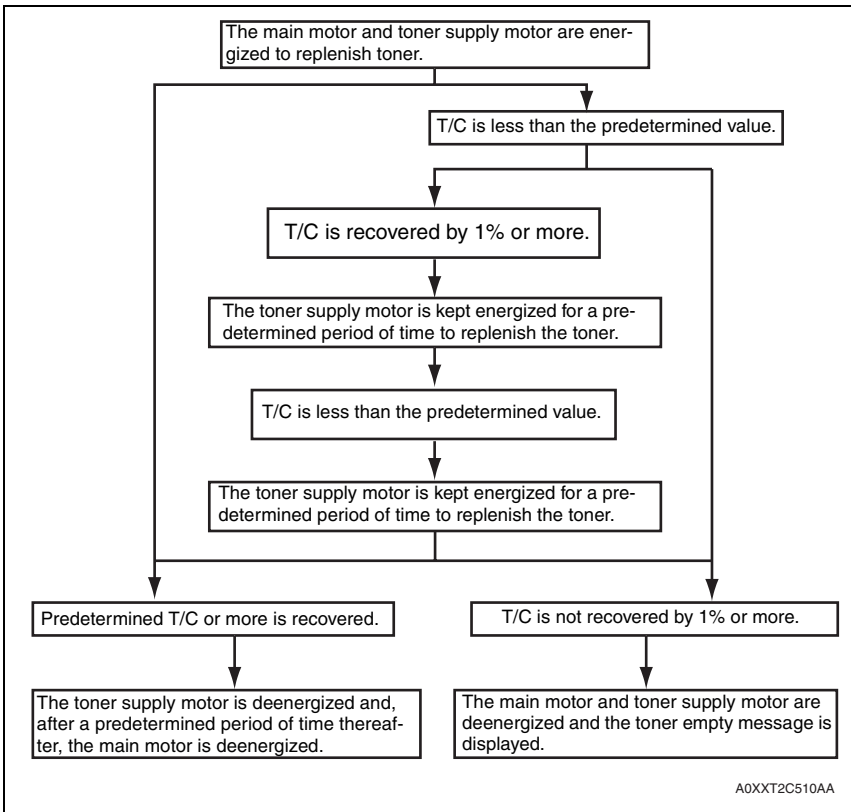

9.3.4 Detection of toner empty condition

- The main body detects a toner empty condition based on the T/C ratio in the developing unit.
- After a toner empty condition is detected, the main body enters the T/C recovery mode to replenish toner.
- If the normal T/C ratio is not recovered even after the T/C recovery sequence is executed, a corresponding message is displayed on the control panel and the main body is brought to a stop.

Condition	Printing	State
T/C 6% or more	Enabled	Normal
T/C less than 6%	Enabled	Toner empty
T/C ratio of less than 4% is detected and a condition of less than 4% T/C is detected five consecutive times.	Prohibited	Toner empty (main body stop)

bizhub 164

COMPOSITION/
OPERATION

10. IMAGING UNIT SECTION

10.1 Configuration

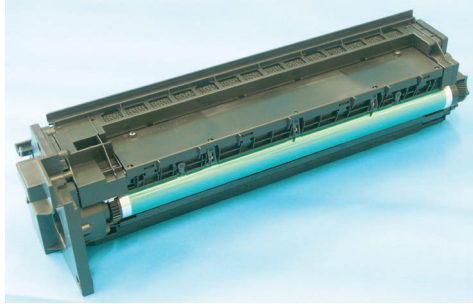

A0XXT2C548AA

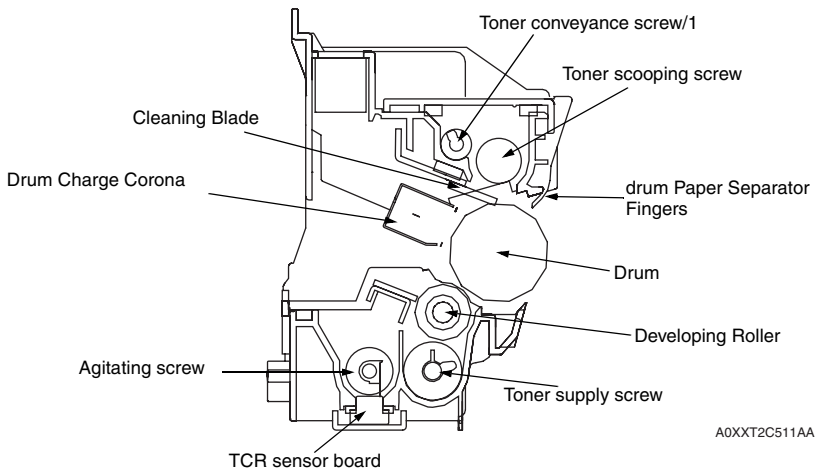

A0XXT2C511AA

10.2 Operation

10.2.1 Imaging unit life detection

- The life of the imaging unit is calculated using the period of time through which the drum is rotated (main motor drive time).
- When the drum rotation time reaches the life value, the life message appear on the control panel.

Life status	Approx. number of prints upon detection
Life	55K
Life stop	69K

11. IMAGING UNIT SECTION (Drum)

11.1 Configuration



A08EC582AA

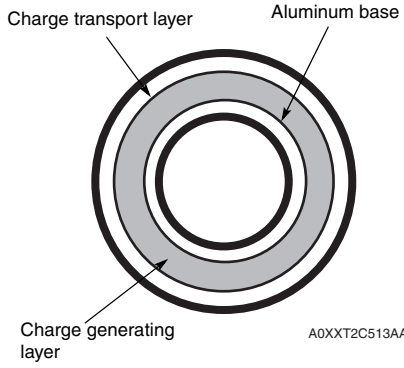

A0XXT2C513AA

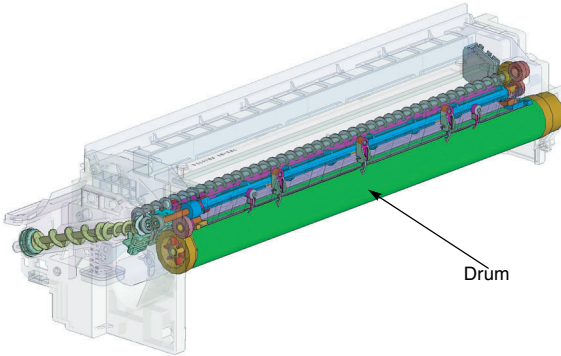

A0XXT2C512AA

bizhub 164

COMPOSITION/
OPERATION

11.2 Drive

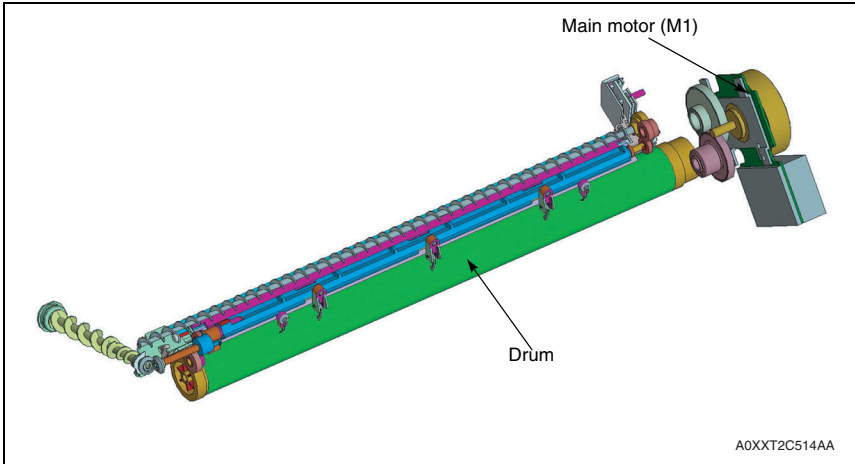

11.3 Operation

11.3.1 Drum drive

- The drum is driven by the main motor via a gear train.
- The main motor drives not only the drum, but also the image transfer system and paper feed and timing drive systems.

12. IMAGING UNIT SECTION (charge corona)

12.1 Configuration



A08EC583AA

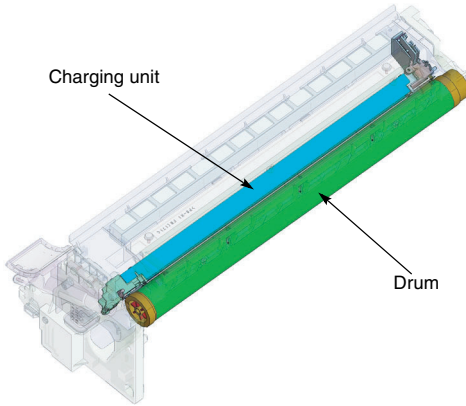

A0XXT2C515AA

12.2 Operation

- The surface of the drum is deposited with charge through corona discharge from the drum charge corona.
- The grid mesh interposed between the corona wire and the drum ensures that a uniform charge is deposited across the entire surface of the drum.
- The corona unit has a comb electrode that discharges only toward the grid mesh. This results in the amount of ozone produced being smaller than with the wire electrode.

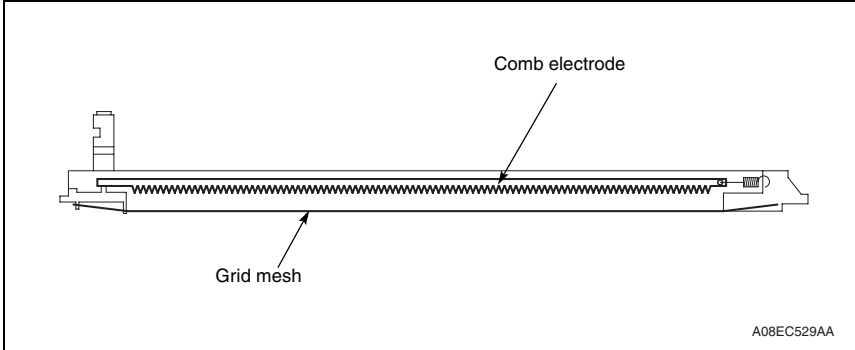

13. IMAGING UNIT SECTION (developing)

13.1 Configuration

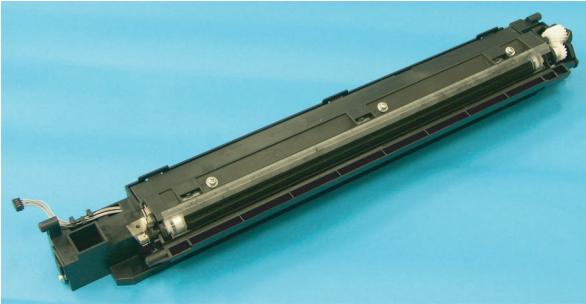

A0XXT2C549AA

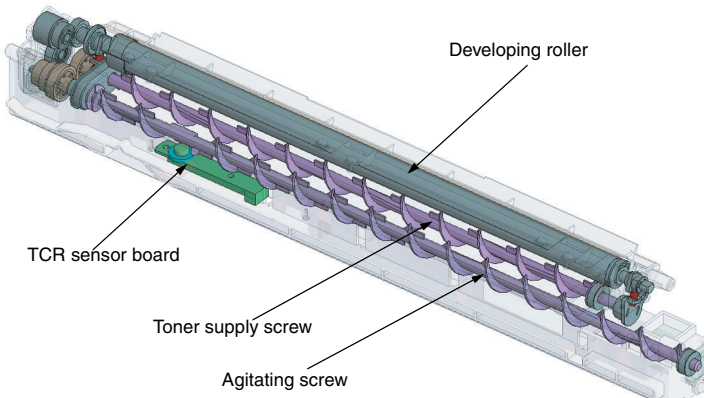

A0XXT2C516AA

bizhub 164

COMPOSITION/
OPERATION

13.2 Drive

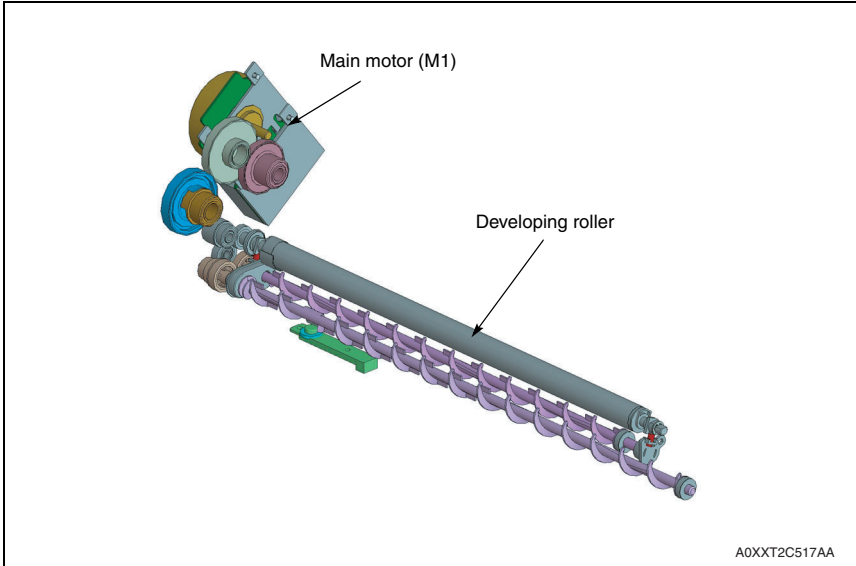

bizhub 164

COMPOSITION/
OPERATION

13.3 Operation

13.3.1 Toner flow

1. Toner in the toner bottle is conveyed to the toner supply port of the developing unit via toner conveying screw/2.
2. The toner is conveyed to the rear side of the main body by the agitating screw and to the front side of the main body by the toner supply screw.
3. The toner level detection mechanism (TCR sensor) detects the T/C ratio of the developer in the developer mixing chamber.
4. The toner conveyed to the toner supply screw is conveyed to the developing roller. At this time, the amount of toner on the developing roller is regulated by the doctor blade.
5. Toner on the developing roller is affixed (conveyed) to the latent image part on the drum.

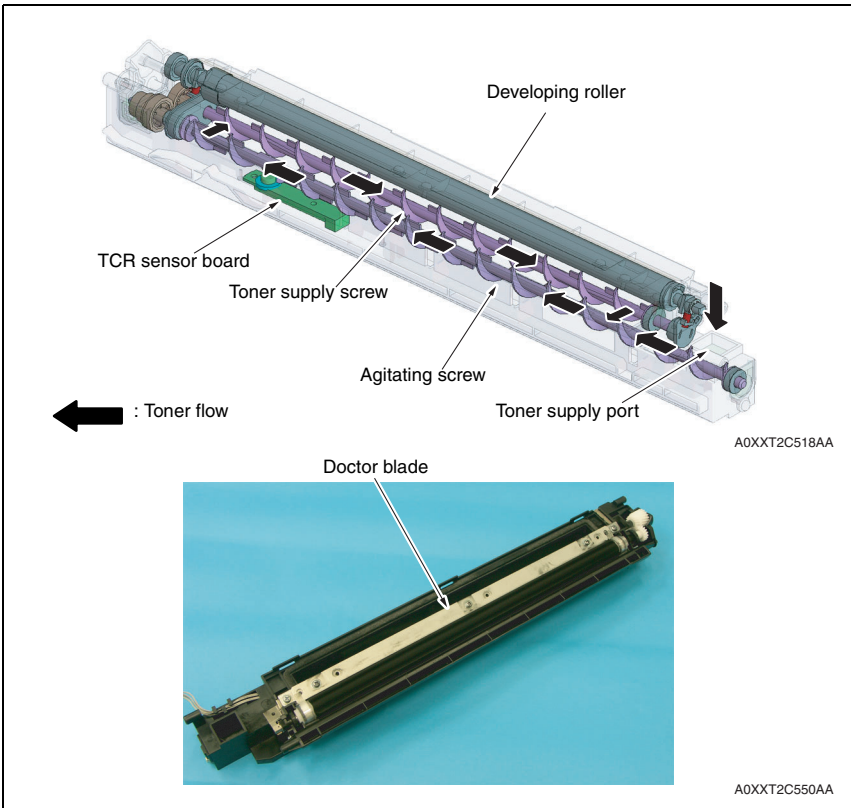

13.3.2 Developing Bias

- Vb (-DC, AC) is applied to the developing roller.
- Vb (-DC) is applied to prevent toner from sticking to the background of the image.
- Vb (AC) is applied to enhance good separation of toner from carrier.
- The amount of toner sticking to the surface of the drum is varied according to the difference in potential between the voltage (V_i) on the surface of the drum and Vb (-DC).
- Large difference = A greater amount of toner sticks.
- Small difference = A smaller amount of toner sticks.

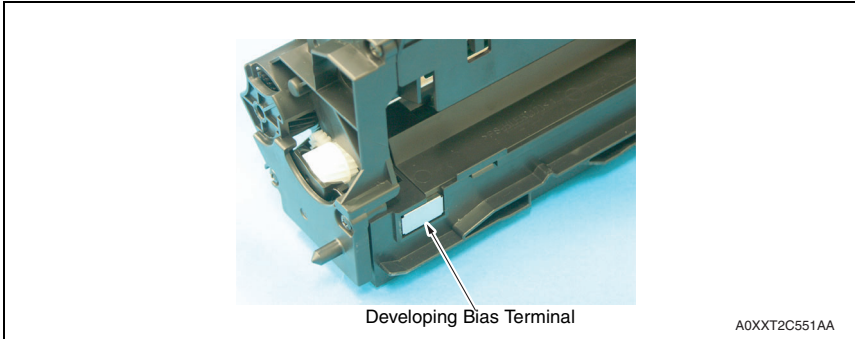

13.3.3 TCR Sensor Automatic Adjustment

- The developer in the developer mixing chamber is forcibly agitated and the output voltage of the TCR sensor is adjusted.
- The output voltage serves as data for calculating the T/C ratio. This adjustment must be made whenever the developers are changed.
That is, make the TCR sensor automatic adjustment only when the developers are changed.

14. TRANSFER/SEPARATION SECTION

14.1 Configuration

bizhub 164

COMPOSITION/
OPERATION



A0XXT2C552AA

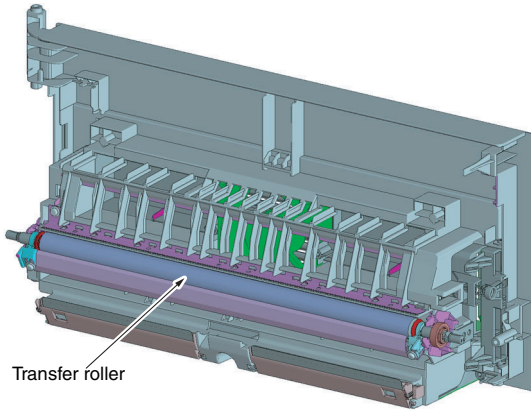

A0XXT2C519AA

14.2 Drive

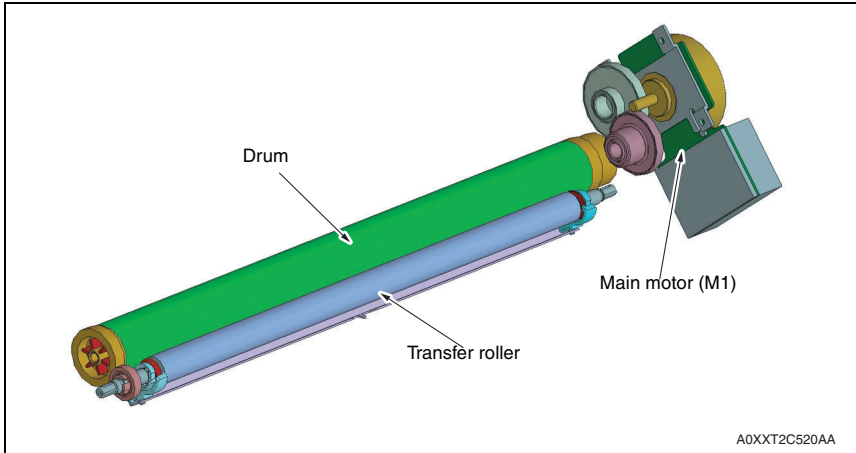

14.3 Operation

14.3.1 Transfer voltage output control

- A positive charge is applied to the image transfer roller to transfer the toner image formed on the surface of the drum onto the paper.
- The charge applied to the image transfer roller is varied according to the following conditions to ensure that image transfer efficiency is stabilized.
 1. Paper width: The smaller the paper width, the greater the amount of charge.
 2. B/W ratio of image: The higher the coverage, the greater the amount of charge.

14.3.2 Transfer roller cleaning control

- DC positive and negative transfer bias voltages are alternately applied to the transfer roller. This allows toner residue on the surface of the transfer roller to be transferred back to the drum, thus cleaning the transfer roller.
- The toner transferred back to the transfer belt is collected by the cleaning blade.

A. Operation timing

- The cleaning is performed during a warm-up cycle after the front or right door is opened and closed.

14.3.3 Paper Separation control

A. Paper neutralization

- To neutralize any charge potential left in the paper which has undergone the image transfer stage, there is the charge neutralizing plate fitted to the guide plate after the transfer roller.

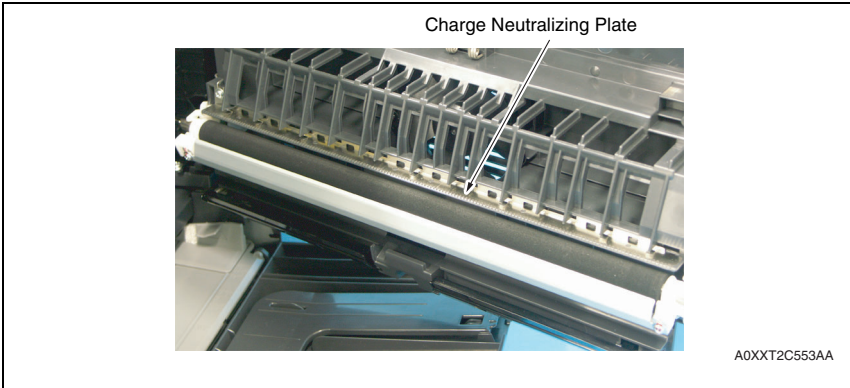

B. Paper separation

- Paper separation is accomplished through the curvature separation system that works on the diameters of the drum and the image transfer roller. Since the drum has a small diameter, there is no likelihood that the paper will be wound around the drum. The paper is separated by its own weight.
- The charge neutralizing plate neutralizes any charge left on the paper after image transfer, thereby preventing discharge noise that could otherwise occur when the paper is separated.
- The drum paper separator fingers properly separate from the surface of the drum thin paper or other type of paper that is hard to separate.

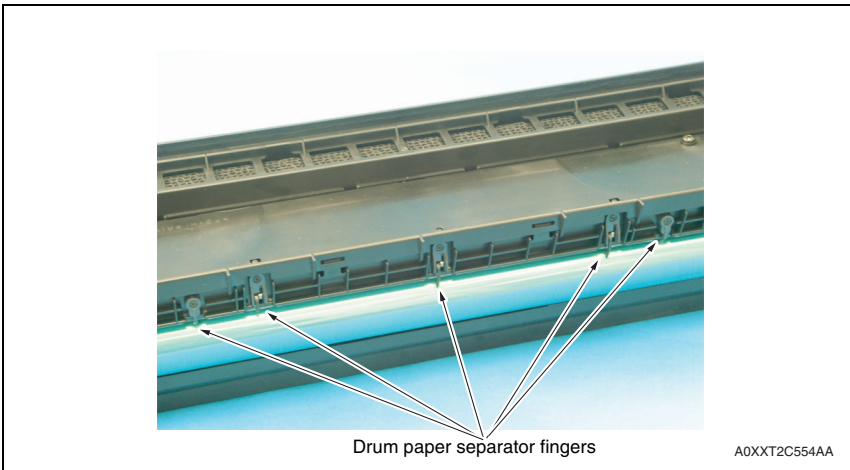

15. TONER COLLECTION SECTION

15.1 Configuration

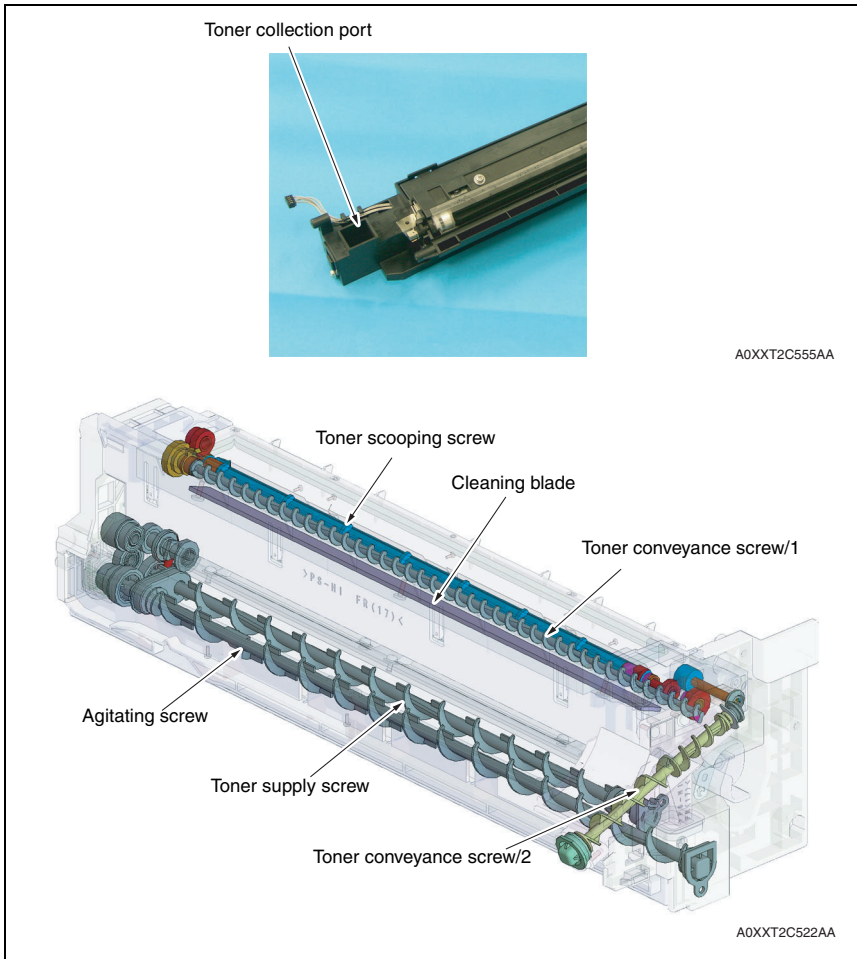

bizhub 164

COMPOSITION/
OPERATION

15.2 Drive

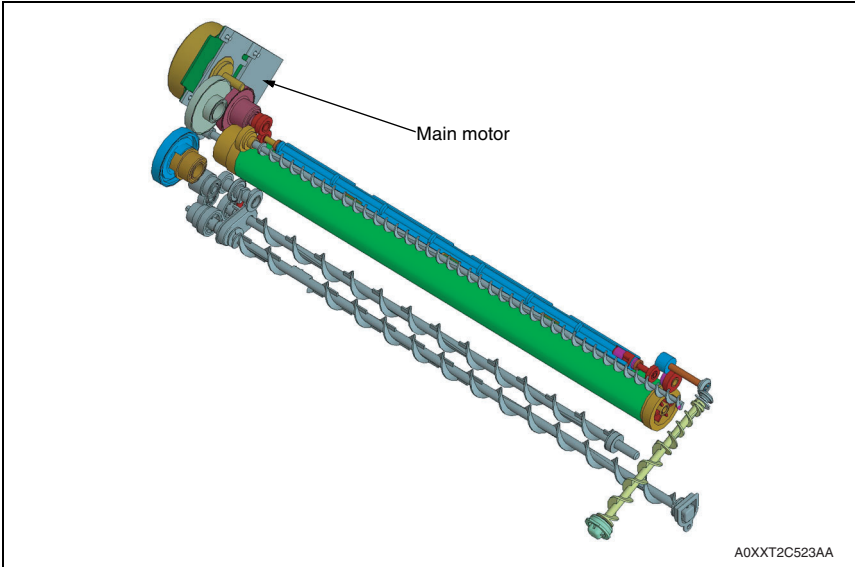

bizhub 164

COMPOSITION/
OPERATION

15.3 Operation

15.3.1 Toner collecting path

- The cleaning blade is used to scrape residual toner off the surface of the drum.
- The toner removed by the cleaning blade is scooped up by the toner scooping screw and conveyed by way of toner conveyance screw/1 and toner conveyance screw/2 onto the developer mixing chamber.
- The following control is provided to prevent paper dust from being wedged between the cleaning blade and the drum. When the cumulative period of time through which the drum has been driven reaches a predetermined value, the drum is turned backward (by turning the Main Motor backward).

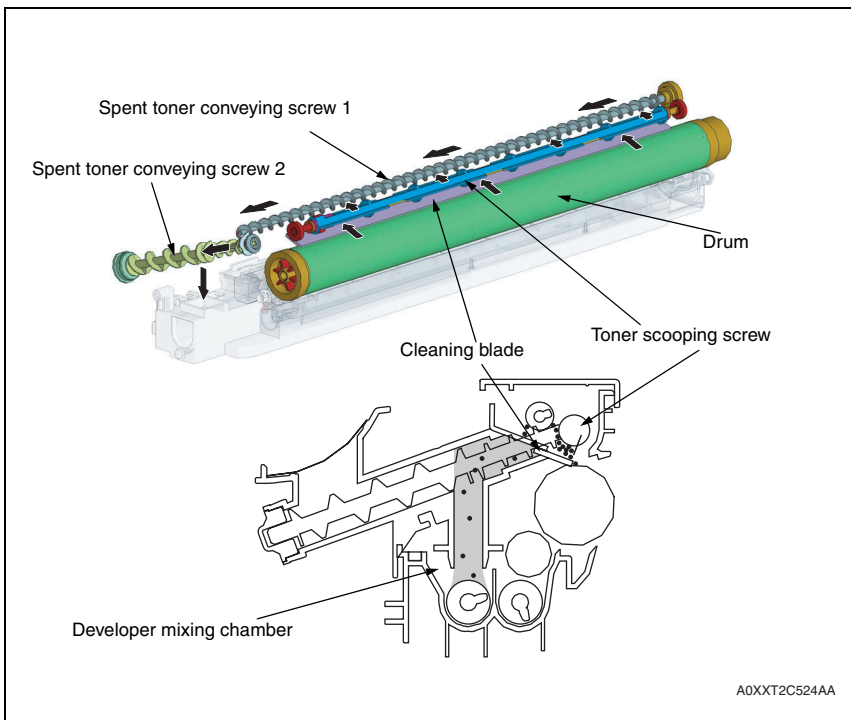

bizhub 164

COMPOSITION/
OPERATION

16. PAPER FEED SECTION (Tray1)

16.1 Configuration

bizhub 164



A0XXT2C556AA

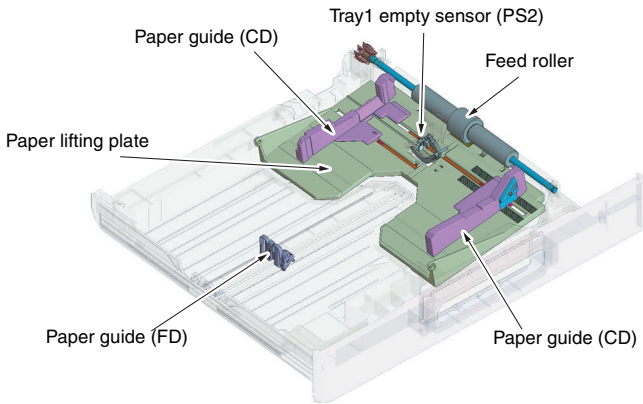

A0XXT2C525AA

COMPOSITION/
OPERATION

16.2 Drive

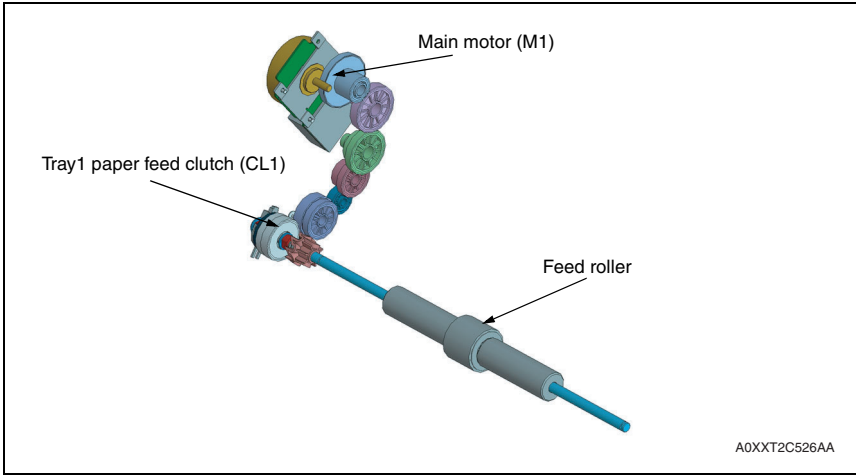

bizhub 164

COMPOSITION/
OPERATION

16.3 Operation

16.3.1 Up/down control

- The media lift plate is pressed down into the locked position (in which the media is loaded in position).
- Load a media stack and then slide the tray into the main body. This causes the lock release lever to unlock the media lift plate.
- The media lift plate (media stack) is pressed against the feed roller.
- The media lift plate (media stack) is pressed upward by the springs at all times.

Lock release lever

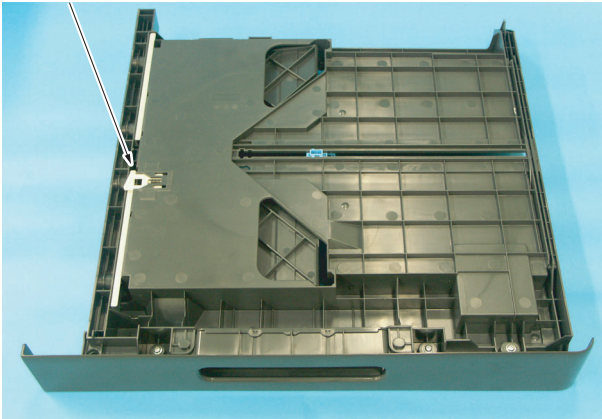

A0XXT2C557AA

16.3.2 Paper feed control

A. Pick-up control

- When the Tray1 paper feed clutch (CL1) is energized, drive from the main motor (M1) is transmitted to the paper feed roller via the paper pick-up clutch and the pick-up roller is rotated.

B. Multiple sheet feeding prevention control

- The fixed separation pad system is used for media separation. This ensures that only the first sheet of media is taken up and fed in.

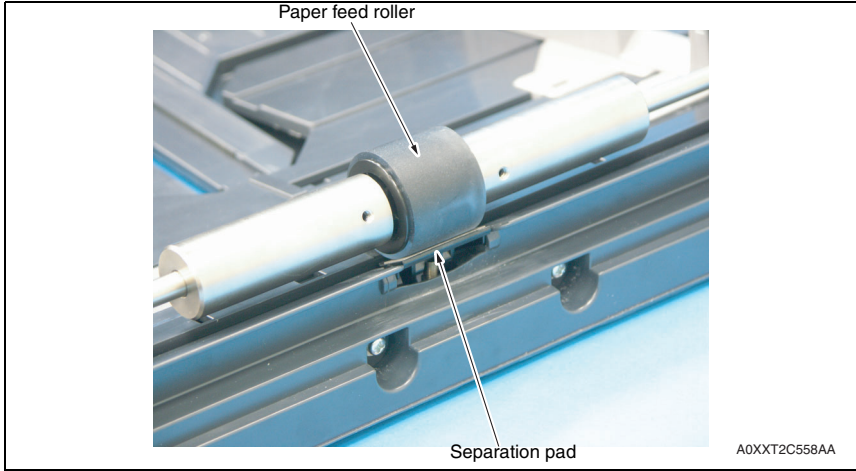

16.3.3 Paper size detection control

- The main body has no system or mechanism for detecting the paper size. The paper size is therefore specified from the control panel after the paper is loaded in the main body.

16.3.4 Remaining paper level detection control

A. Paper empty detection

- The Tray1 empty sensor (PS2) detects a paper-empty condition in the drawer.
- When paper runs out, the actuator is raised to unblock the tray1 empty sensor and the corresponding message appears on the control panel.
- The press of the start key does not start a copy cycle when no paper is loaded in the drawer.

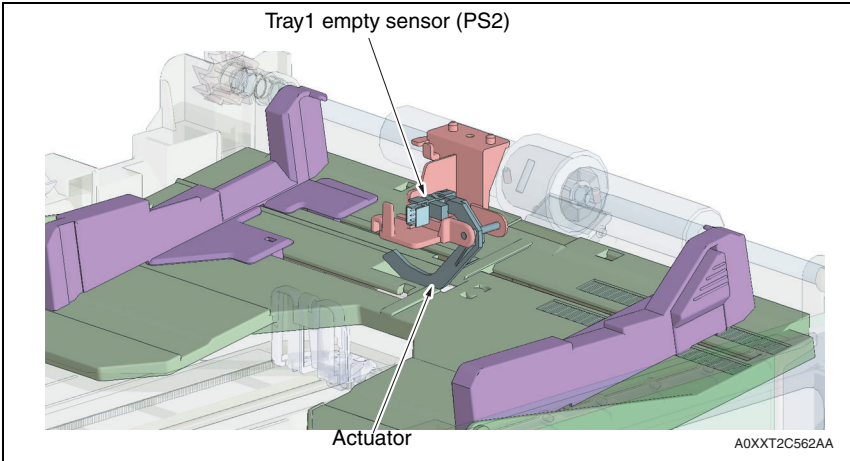

17. MULTI BYPASS SECTION (MB-503)

*: Standard on the product shipped to China.

17.1 Configuration

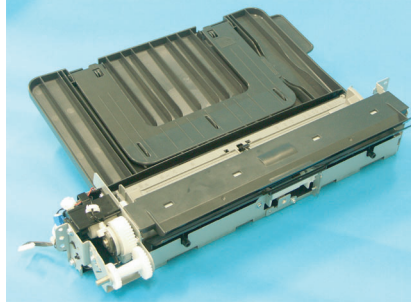

A0XXT2C559AA

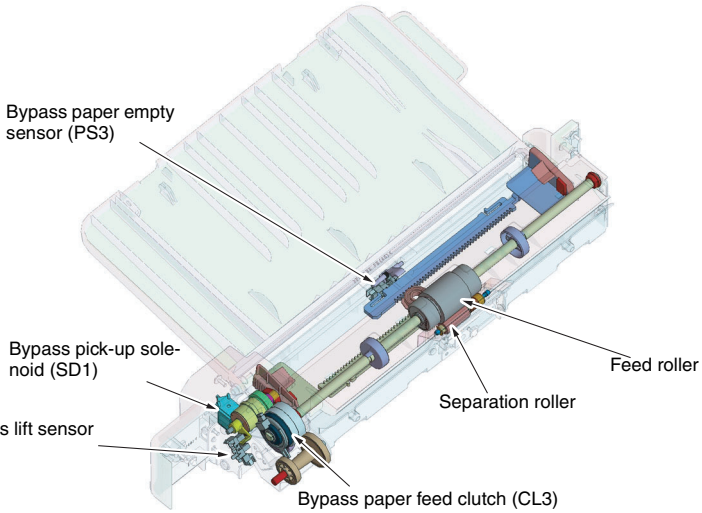

A0XXT2C527AA

17.2 Drive

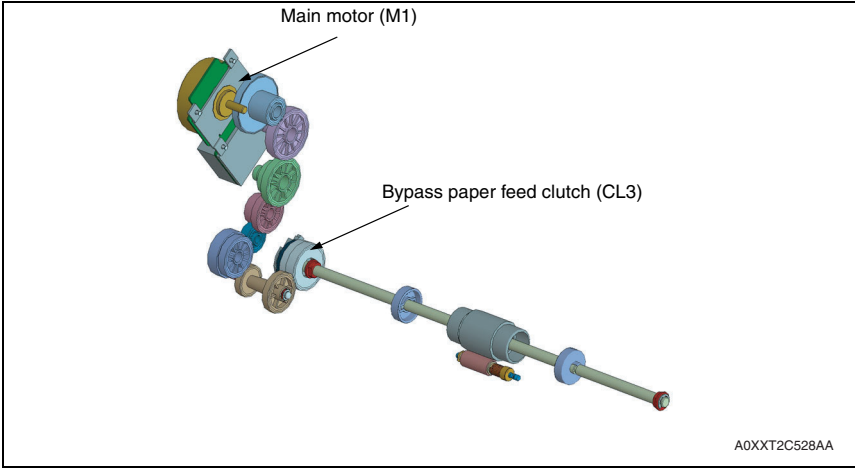

bizhub 164

COMPOSITION/
OPERATION

17.3 Operation

17.3.1 Up/down control

- The paper lifting plate is raised to press the paper stack on the tray up against the feed roller.
- When the bypass paper feed clutch is energized, the cam is rotated to raise the paper lifting plate.
- When the bypass paper feed clutch is energized again, the cam is rotated to lower the paper lifting plate.
- The ascent and descent motion of the paper lifting plate is controlled using the bypass lift sensor. The ascent or descent motion is stopped after the lapse of a predetermined period of time after the sensor has been blocked or unblocked (blocked: stopping the ascent motion; unblocked: stopping the descent motion).

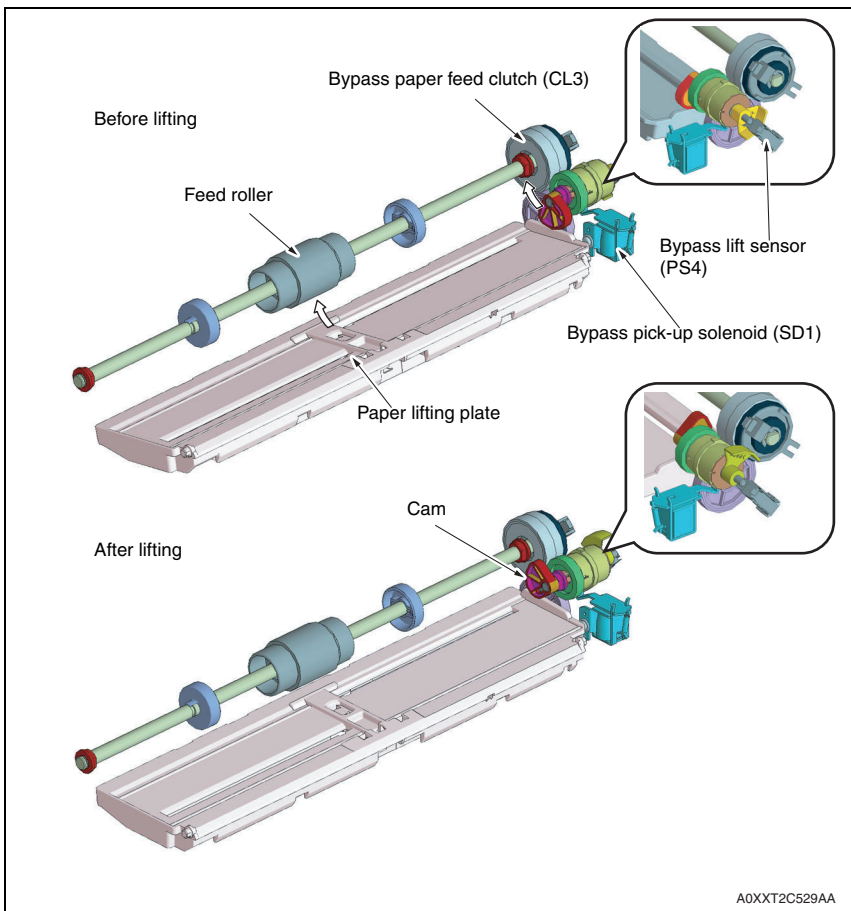

bizhub 164

COMPOSITION/
OPERATION

17.3.2 Paper feed control

A. Pick-up control

- The feed roller is driven by the main motor through the bypass paper feed clutch.
- When the bypass paper feed clutch (CL3) is energized, drive from the main motor (M1) is transmitted to the pick-up roller via the paper pick-up clutch and the pick-up roller is rotated.

B. Multiple sheet feeding prevention control

- The coefficient of friction between the Feed Roller and Separation Roller is effectively used to prevent double feed of paper.

When one sheet of paper is taken up:

The coefficient of friction on the front side of the sheet of paper taken up and fed through the space between the feed roller and separation roller is the same as that on the backside of the sheet of paper, allowing the paper to be properly fed into the machine.

When two or more sheets of paper are taken up:

- The coefficient of friction between the paper and the separation roller is greater than that between the sheets of paper, which allows only the top sheet of paper to be fed into the machine.

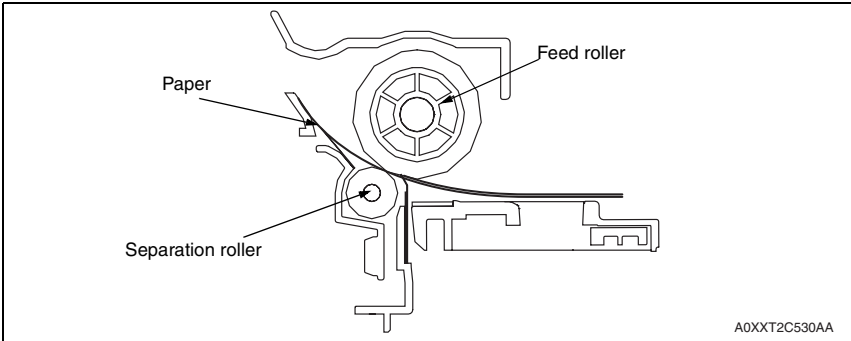

17.3.3 Remaining paper level detection control

A. Paper empty detection

- The bypass paper empty sensor (PS3) detects a paper-empty condition in the drawer.
- When paper runs out, the actuator is raised to block the tray1 empty sensor.
- When the tray1 empty sensor is blocked, the bypass pick-up solenoid is energized and the paper lifting plate is lowered.
- the press of the start key does not start a copy cycle when no paper is loaded in the bypass section.

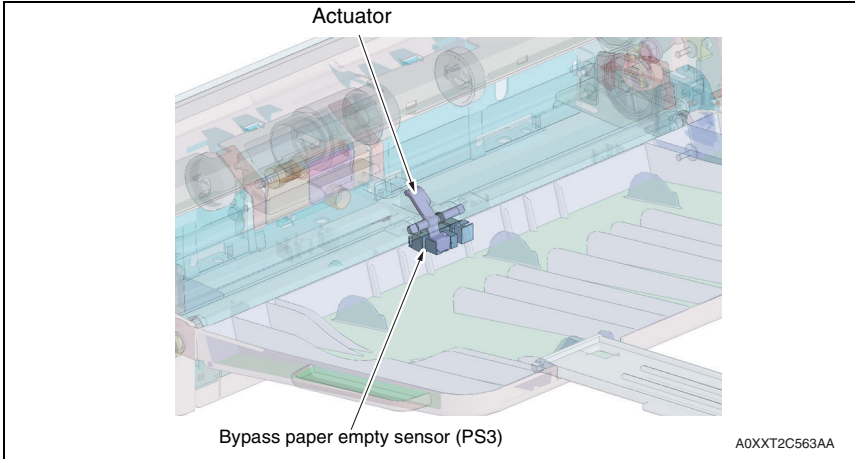

18. REGISTRATION SECTION

18.1 Configuration

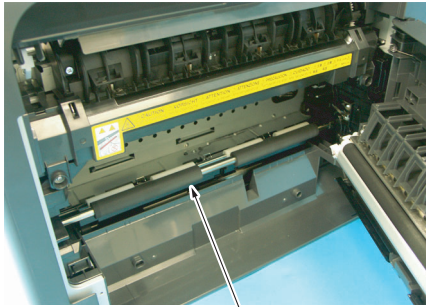

Registration roller

A0XXT2C560AA

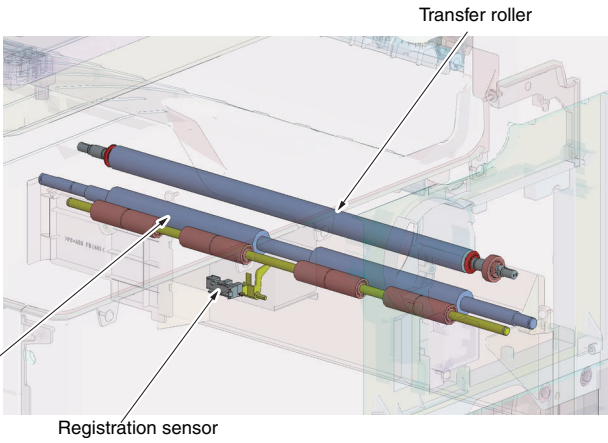

Registration roller

Registration sensor

Transfer roller

A0XXT2C531AA

bizhub 164

COMPOSITION/
OPERATION

18.2 Drive

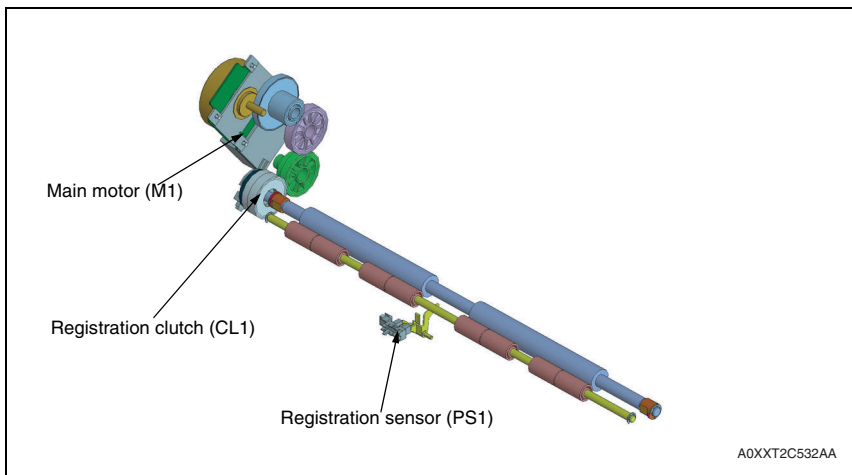

18.3 Operation

18.3.1 Registration control

- The main motor provides the drive for the registration roller.
- The registration roller clutch is connected to the registration roller. When the registration roller clutch is energized, the driving force of the main motor is transmitted to the registration roller. This rotates the registration roller.
- During paper transport, a loop is formed in the paper between the tray 1 feed roller (bypass feed roller) and the registration roller to thereby correct any skew in the paper.
- Registration roller is controlled in order to synchronize the timing the unit starts writing the image and conveying paper.

A. Adjustment

- The amount of the loop in the paper can be varied using "SERVICE'S CHOICE - LOOP Ad. (TRAY1) / LOOP Ad. (BYPASS)".
Changing the adjustment value will vary the timing at which the registration clutch is energized.

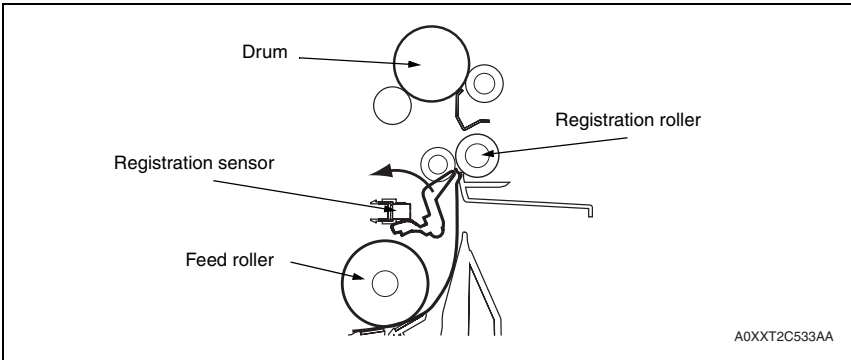

19. FUSING SECTION

19.1 Configuration

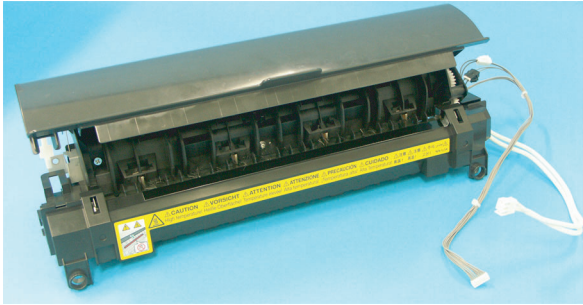

A0XXT2C561AA

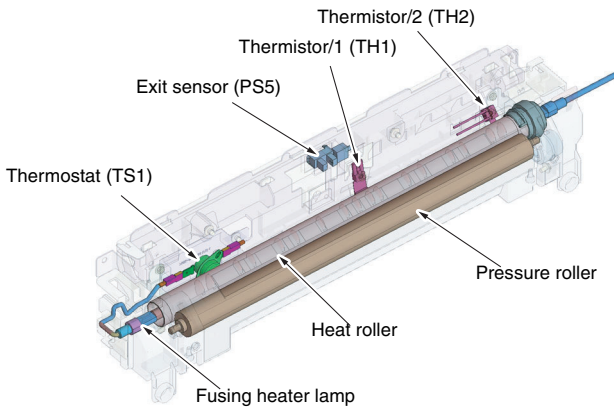

A0XXT2C534AA

19.2 Drive

- The main motor (M1) provides the drive for the fusing unit.

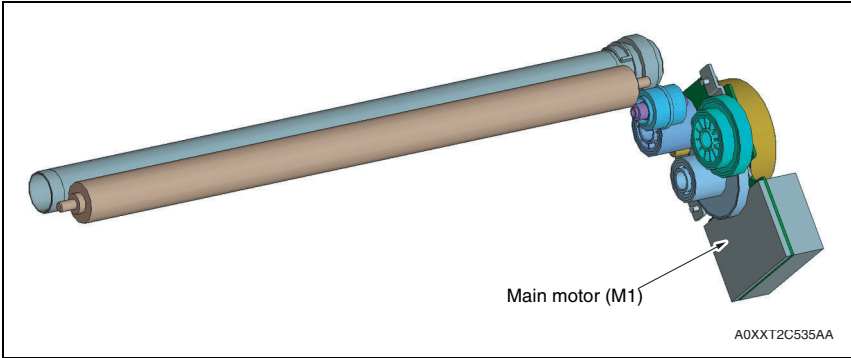

19.3 Operation

19.3.1 Fusing speed correction

A. Heat roller speed control

- The heat roller is driven by the main motor.
- The pressure roller, which is pressed up against the heat roller, is driven by the heat roller.

19.3.2 Fusing pressure control

- The pressure roller is directly pressed up against the heat roller by the pressure spring.

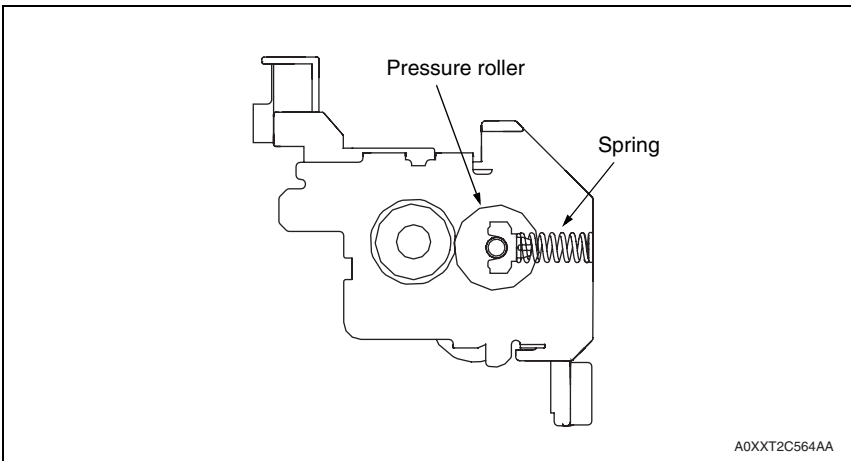

19.3.3 Fusing temperature control

- The fusing heater lamp is turned on and off to keep a set temperature on the surface of the Fusing Roller.
- The fusing roller surface temperature is detected by using a thermistor that translates the temperature to a corresponding electrical signal.
- If the fusing roller temperature becomes excessively high, the fusing roller heater lamp is shut down.

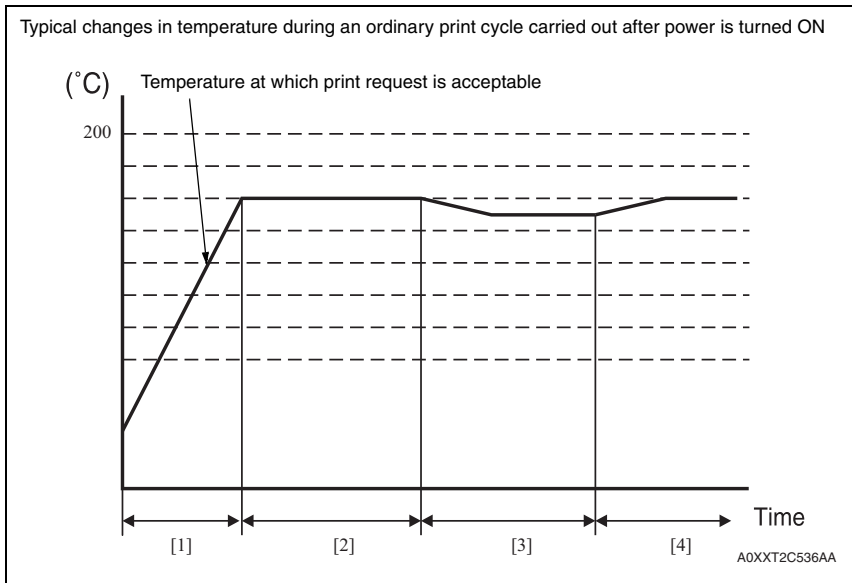

[1] During warm-up cycle

[2] In standby state

[3] During a print cycle

[4] In standby state

A. Temperature control during warm-up

- Control is provided until the Heat roller reaches the predetermined level.

(1) Control start timing

- The power switch is turned ON.
- A door is closed.
- The main body leaves the sleep mode.

(2) Control termination timing

- The fusing roller reaches a predetermined temperature.
- A door is opened.

B. Temperature control during stand-by

- Control is provided to ensure that the temperature of the fusing roller becomes a constant value during the standby state.

(1) Control start timing

- At the end of the warm-up control
- At the end of a print cycle

(2) Control termination timing

- At the start of a print cycle
- A door is opened.
- A malfunction or media misfeed occurs.

C. Temperature control during printing

- The fusing speed and fusing temperature are controlled to ensure a sufficient fusing strength.

(1) Control start timing

- A print request is received.

(2) Control termination timing

- A malfunction or media misfeed occurs.

(3) Print control temperatures

- The fusing roller temperature is controlled by setting an optimum temperature of the heat roller according to the size and type of the media.
- As an example, there is a difference in the controlled temperature of about 10°C between the plain paper and card1/2, and between A4 size and A3 size.

D. Temperature control during sleep mode

- The fusing heater is turned OFF during the sleep mode.

19.3.4 Protection from abnormally high temperature

A. First approach: Thermistor protection (Software protection)

- The main body determines that there is a condition of an abnormally high temperature when thermistor/1 continuously detects a predetermined temperature or more for a predetermined period of time or more. The main body then gives the following message: "Trouble code C3751 (Fusing failure: abnormally high fusing temperature 1)".
- The main body determines that there is a condition of an abnormally high temperature when thermistor/2 continuously detects a predetermined temperature or more for a predetermined period of time or more. The main body then gives the following message: "Trouble code C3751 (Fusing failure: abnormally high fusing temperature 1)". The main body prohibits the initiation of any new print cycle as soon as it displays the trouble code.
- When the trouble code is displayed, printing will be prohibited.

B. Second approach: Thermistor protection (Hardware protection)

- If either thermistor/1 or thermistor/2 detects an abnormally high temperature when the CPU overruns to be unable to detect an abnormally high temperature trouble, the heater relay of the DC power supply unit is turned OFF via the printer control board, thereby shutting down power supplied to the fusing heater lamp.
- The power supplied to the fusing heater lamp can be shut down before the thermostat of the third approach is activated. This inhibits damage to the fusing unit.

C. Third approach: Thermostat protection

- If the abnormally high temperature through the first and second approach cannot be detected because of a faulty thermistor, the thermostat comes into play to shut down the power supplied to the fusing heater lamp.

19.3.5 PPM Control

- To ensure good fusing characteristics of the image printed on the media, the number of continuously prints is held low, thus preventing fusing characteristics during the multi-print cycle from being degraded.
- When card 1/2 is selected, the main motor is deenergized to provide a delay of 4 seconds in the paper feed start sequence regardless of the paper size. Further, the PPM control (4-sec. delay in paper feed start sequence) is performed, if +2 or more is selected for the plain paper temperature choice in the FUSER TEMP menu of SERVICE'S CHOICE.

19.3.6 Control for preventing roller edge temperature from rising

- If paper of a small size or card1/2 is used to run a multi-copy cycle, the temperature on the edges of the heat roller tends to increase, so that the temperature of the heat roller varies among different spots of the roller.
- A temperature increase prevention control is performed during a multi-print cycle to thereby delay the paper feed operation, so that the temperature of the heat roller can be controlled to achieve a uniform temperature of the roller.
- Thermistor/2 measures the temperature of the edges of the roller.
- When a predetermined temperature or more is detected from the edges of the roller, the print cycle is temporarily stopped.
- The print cycle is resumed as soon as the temperature of the edges of the roller decreases to reach the predetermined level. If the temperature does not decrease down to the predetermined level even after the lapse of 30 seconds, the print cycle is resumed regardless of whether the predetermined temperature is reached.

19.3.7 New article detection

- The fusing unit is not mounted with any new article detection mechanism.
- If the fusing unit is replaced with a new one, reset the counter using [CLEAR DATA] of the service mode.
[SERVICE MODE] / [CLEAR DATA] / [PM COUNTER] / [FUSING] menu.

20. PAPER EXIT SECTION

20.1 Configuration



A0XXT2C565AA

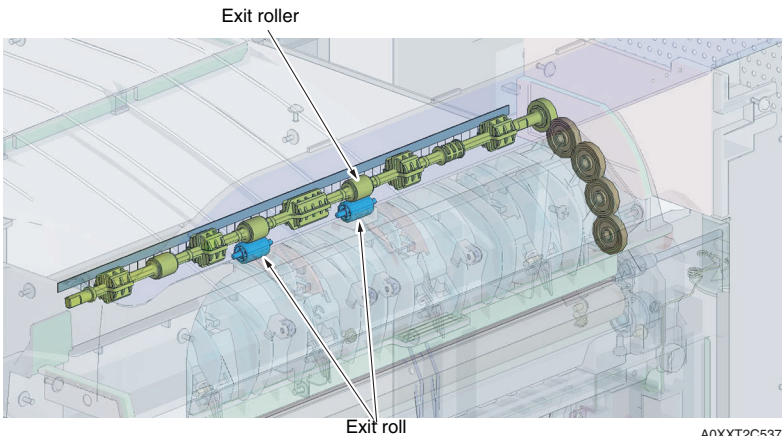

A0XXT2C537AA

20.2 Drive

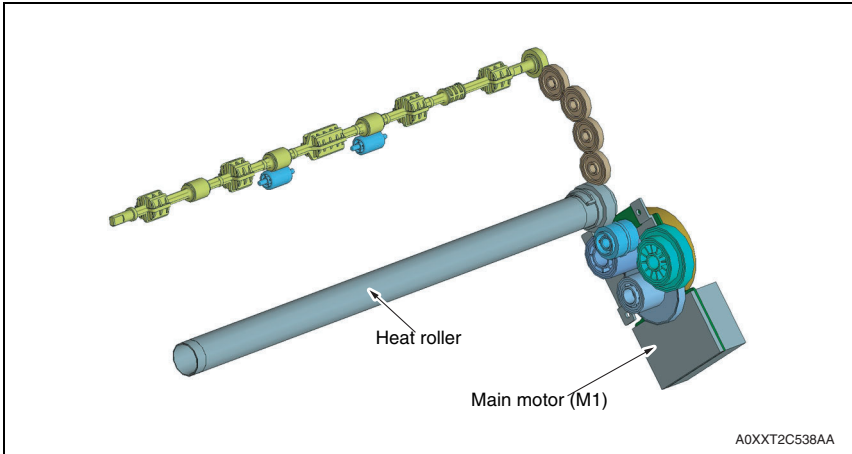

20.3 Operation

20.3.1 Conveyance control

A. Conveyance path

- The exit roller is driven by the main motor.
- The media conveyed from the fusing section is fed out into the exit tray.

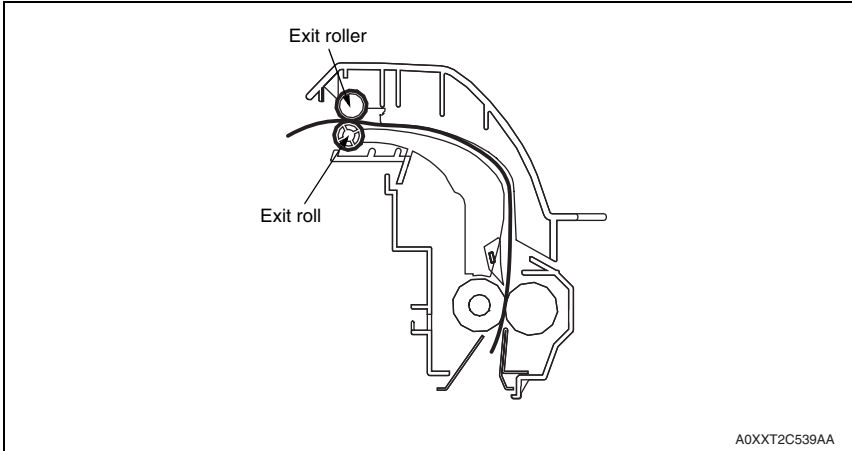

21. IMAGE STABILIZATION CONTROL

21.1 Configuration

- The following image stabilization controls are provided to ensure stabilized copy image.

Purpose	Means	Control
To stabilize image density.	Grid bias voltage (Vg) Developing bias (Vb)	The Vg/Vb control voltage is varied to bring Vg/Vb to an appropriate level according to the following settings. <ul style="list-style-type: none"> ID ADJUST (Service mode) VG ADJUST (Service mode) Print Density (Utility) SUPPLIES LIFE COUNT. (Service mode)
To stabilize image transfer.	Transfer voltage (Vt) Transfer electrical current (It)	The image transfer output is varied to bring the image transfer electrical current to an appropriate level according to the following conditions. <ul style="list-style-type: none"> Paper type Paper size B/W ratio of image

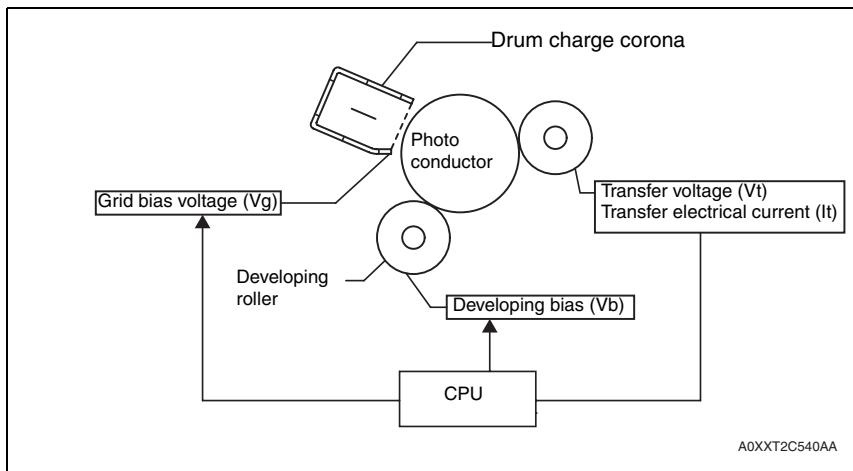

bizhub 164

COMPOSITION/
OPERATION

22. POWER SUPPLY SECTION

22.1 When the main power switch is turned ON

22.1.1 Configuration

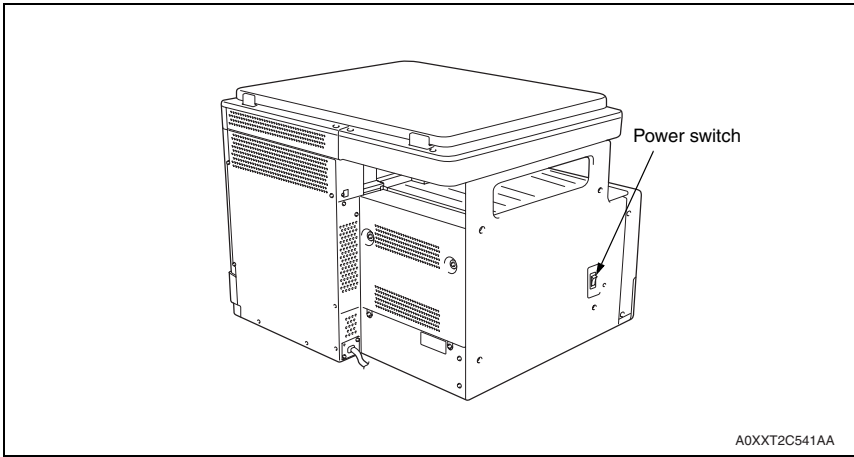

22.1.2 Operation

- When the main power switch is turned ON, power is supplied from the dc power supply to the following components.

Voltage	Power supplied to
24 V	Printer control board, High voltage unit, PH unit
3.3 V	

bizhub 164

COMPOSITION/
OPERATION

23. FAN CONTROL

23.1 Configuration

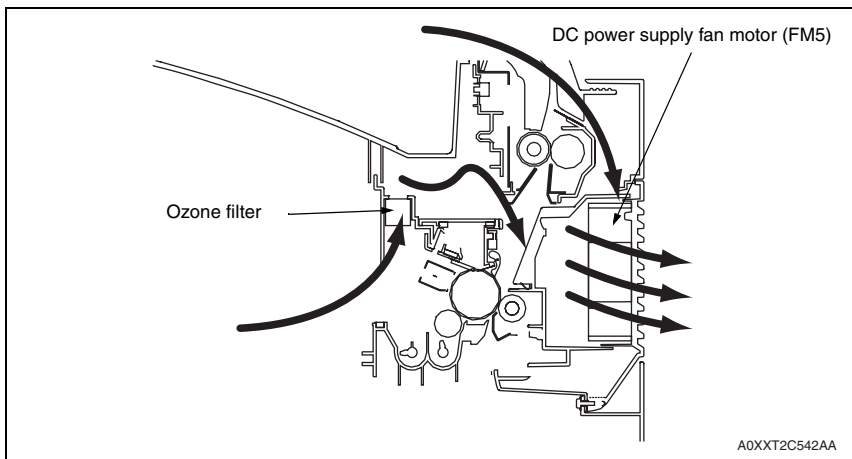

23.2 Operation

23.2.1 Function

Motor Name	Function (purpose)
DC power supply fan motor (FM5)	<ul style="list-style-type: none"> A fan motor draws air from the area around the fusing unit to the outside to prevent the machine interior temperature from running high. In addition, the fan motor pulls paper being transported up through suction force to help stabilize paper transport. Ozone produced from the drum charge corona is absorbed by the ozone filter from the air drawn by a fan motor to the outside.

23.2.2 Fan control

Motor Name	Control	Control Conditions
DC power supply fan motor (FM5)	ON (high speed)	<ul style="list-style-type: none"> During rotation of the main motor (M1)
	ON (medium speed)	<ul style="list-style-type: none"> No control
	ON (low speed)	<ul style="list-style-type: none"> No control
	Stop	<ul style="list-style-type: none"> Conditions other than those of ON (high speed)

Blank Page



KONICA MINOLTA

© 2010 KONICA MINOLTA BUSINESS TECHNOLOGIES, INC.

Use of this manual should be strictly supervised to
avoid disclosure of confidential information.

Printed in Japan
DDA0XX-M-TE1