

PC400/420/430

FC200/220

SERVICE

MANUAL

REVISION 0

Canon

JAN.1998

FY8-13F2-000

IMPORTANT

THIS DOCUMENTATION IS PUBLISHED BY CANON INC., JAPAN, TO SERVE AS A SOURCE OF REFERENCE FOR WORK IN THE FIELD.

SPECIFICATIONS AND OTHER INFORMATION CONTAINED HEREIN MAY VARY SLIGHTLY FROM ACTUAL MACHINE VALUES OR THOSE FOUND IN ADVERTISING AND OTHER PRINTED MATTER.

ANY QUESTIONS REGARDING INFORMATION CONTAINED HEREIN SHOULD BE DIRECTED TO THE COPIER SERVICE DEPARTMENT OF THE SALES COMPANY.

THIS DOCUMENTATION IS INTENDED FOR ALL SALES AREAS, AND MAY CONTAIN INFORMATION NOT APPLICABLE TO CERTAIN AREAS.

COPYRIGHT © 1998 CANON INC.

***Printed in Japan
Imprimé au Japon***

Use of this manual should be strictly supervised to avoid disclosure of confidential information.

Prepared by

OFFICE IMAGING PRODUCTS TECHNICAL SUPPORT DEPARTMENT 1
OFFICE IMAGING PRODUCTS TECHNICAL SUPPORT DIVISION

CANON INC.

5-1, Hakusan 7-chome, Toride-shi, Ibaraki 302 Japan

INTRODUCTION

This Service Manual provides information needed to service the plain paper copiers FC200/PC400(120V model), FC220/PC420(120V model), and PC430(LGL model) in the field.

The FC200/PC400 differs from the FC220/PC420/PC430 for the following:

Model	Manual pick-up	Multifeeder	AE
FC220/PC420/PC430	Not available	Available	Available
FC200/PC400	Available	Not available	Not available

This Service Manual consists of the following chapters:

CHAPTER 1, "General Description," introduces the copier's features and specifications, shows how to operate the copier, and explains how copies are made.

CHAPTER 2, "Basic Operation," provides outlines of the copier's various mechanical workings.

CHAPTER 3, "Exposure System," discusses the principles of operation used for the copier's lens drive unit and scanner drive unit. It also explains the timing at which these drive units are operated, and shows how they may be disassembled/assembled and adjusted.

CHAPTER 4, "Image Formation System," discusses the principles of how images are formed. It also explains the timing at which the various units involved in image formation are operated, and shows how they may be disassembled/assembled and adjusted.

CHAPTER 5, "Pick-Up/Feeding System," explains the principles used from when copy paper is picked up to when a copy is delivered in view of the functions of electrical and mechanical units and in relation to their timing of operation. It also shows how these units may be disassembled/assembled and adjusted.

CHAPTER 6, "Fixing System," explains the principles used to fuse toner images to transfer media in view of the functions of electrical and mechanical units and in relation to their timing of operation. It also shows how these units may be disassembled/assembled and adjusted.

CHAPTER 7, "Externals/Auxiliary Mechanisms," shows the copier's external parts, and explains the principles used for the copier's various control mechanisms in view of the functions of electrical and mechanical units and in relation to their timing of operation. It also shows how these units may be disassembled/assembled and adjusted.

CHAPTER 8, "Installation," introduces requirements for the site of installation, and shows how the copier may be installed using step-by-step instructions.



CHAPTER 9, "Maintenance and Servicing," provides tables of periodically replaced parts and consumables/durables and scheduled servicing charts.

CHAPTER 10, "Troubleshooting," provides tables of maintenance/inspection, standards/adjustments, and problem identification (image fault/malfunction).

Appendix contains a general timing chart and general circuit diagrams.

The following rules apply throughout this Service Manual:

1. Each chapter contains sections explaining the purpose of specific functions and the relationship between electrical and mechanical systems with reference to the timing of operation.

In the diagrams,  represents the path of mechanical drive—where a signal name accompanies the symbol , the arrow indicates the direction of the electric signal.

The expression "turn on the power" means flipping on the power switch, closing the front door, and closing the delivery unit door, which results in supplying the machine with power.

2. In the digital circuits, '1' is used to indicate that the voltage level of a given signal is "High," while '0' is used to indicate "Low." (The voltage value, however, differs from circuit to circuit.)

In practically all cases, the internal mechanisms of a microprocessor cannot be checked in the field. Therefore, the operations of the microprocessors used in the machines are not discussed: they are explained in terms of from sensors to the input of the DC controller PCB and from the output of the DC controller PCB to the loads.

Note:

The descriptions in this Service Manual are subject to change without notice for product improvement or other purposes, and major changes will be communicated in the form of Service Information bulletins.

All service persons are expected to have a good understanding of the contents of this Service Manual and all relevant Service Information bulletins and be able to identify and isolate faults in the machine.

CONTENTS

CHAPTER 1 GENERAL DESCRIPTION

I. FEATURES	1-1	1. Time to Replace the Cartridge	1-11
II. SPECIFICATIONS	1-2	2. Replacing the Cartridge ...	1-12
III. NAMES OF PARTS	1-4	F. Changing the Density	1-14
A. External View	1-4	G. Cleaning.....	1-14
B. Cross Section	1-5	1. Copyboard Glass/Copyboard Cover	1-14
IV. OPERATION	1-6	2. Lens Array	1-15
A. Control Panel	1-6	3. Pick-Up Roller.....	1-16
1. PC420/430/FC220	1-6	H. When Not Using the Copier for a Long Time	1-16
2. PC400/FC200	1-7	V. IMAGE FORMATION	1-17
B. Making Copies	1-8	A. Outline.....	1-17
C. Jam Indicator.....	1-11		
D. Add Paper Indicator	1-11		
E. Replacing the Cartridge	1-11		

CHAPTER 2 BASIC OPERATION

I. BASIC OPERATION	2-1	1. Inputs to DC Controller (1/2)	2-6
A. Outline	2-1	2. Inputs to DC Controller (2/2)	2-7
B. Outline of Electrical Circuit.....	2-2	F. Outputs from DC Controller ...	2-8
C. Basic Sequence of Operations (A4, 2 copies).....	2-3	1. Outputs from DC Controller (1/2)	2-8
D. Main Motor Control Circuit	2-5	2. Outputs from DC Controller (2/2)	2-9
1. Outline	2-5		
2. Operation	2-5		
3. Overcurrent Sensor	2-5		
E. Inputs to DC Controller	2-6		

CHAPTER 3 EXPOSURE SYSTEM

I. EXPOSURE/COPYBOARD DRIVE SYSTEM	3-1	2. Controlling the Intensity of the Scanning Lamp.....	3-8
A. Outline of Exposure System ...	3-1	C. Controlling the Intensity of the Scanning Lamp (VR604)	3-8
B. Copyboard Drive System.....	3-1	III. MECHANICAL SYSTEM.....	3-9
1. Outline	3-1	A. Scanning System.....	3-10
2. Controlling the Copyboard Drive	3-3	1. Detaching the Scanning Lamp Unit	3-10
3. Mechanism of Copyboard Drive Assembly.....	3-4	B. Copyboard Drive Assembly...3-11	
II. Controlling the Scanning Lamp....	3-7	1. Detaching the Copyboard Drive Assembly	3-11
A. Outline	3-7		
B. Operations	3-8		
1. Turning the Scanning Lamp ON and OFF	3-8		

CHAPTER 4 IMAGE FORMATION SYSTEM

- I. PROCESS DESCRIPTION.....4-1
 - A. Outline4-1
 - B. Sequence of Image Formation Operations (A4, 2 copies)4-2
 - C. Primary Charging Control Circuit4-3
 - 1. Outline4-3
 - 2. Operations4-4
 - D. Controlling Developing Bias....4-6
 - 1. Outline4-6
 - 2. Operations4-8
 - E. Transfer Charging Control Circuit4-10
 - 1. Outline4-10
 - 2. Operations4-11
 - F. Document Density Measurement (AE; PC420/430/FC220).....4-14
 - 1. Outline4-14
 - 2. Operations4-14
 - 3. Adjusting the AE Mechanism (VR602, VR603)4-15
- II. CHARGING, DEVELOPING, AND CLEANING SYSTEMS4-17
 - A. Cartridge4-17
 - 1. Outline4-17
- III. MECHANICAL SYSTEM.....4-18
 - A. Photosensitive Drum.....4-19
 - 1. Cleaning the Drum.....4-19
 - B. Transfer Charging Roller.....4-20
 - 1. Cleaning the Transfer Charging Roller.....4-20
 - 2. Detaching the Transfer Charging Roller.....4-20

CHAPTER 5 PICK-UP/FEEDING SYSTEM

- I. OUTLINE5-1
- II. CONTROLLING THE PICK-UP ROLLER.....5-2
 - A. PC420/430/FC2205-2
 - B. PC400/FC2005-3
- III. CONTROLLING THE REGISTRATION ROLLER5-4
 - A. Outline5-4
 - B. Pick-Up/Feeding Timing Chart (A4, 2 copies).....5-5
- IV. CHECKING FOR JAMS.....5-6
 - A. Delivery Delay Jam.....5-6
 - 1. PC420/430/FC2205-6
 - 2. PC400/FC2005-6
 - B. Delivery Stationary Jam.....5-7
 - 1. PC420/430/FC2205-7
 - 2. PC400/FC2005-7
 - C. Pick-Up Delay Jam (PC420/430/FC220).....5-8
 - D. Pick-Up Stationary Jam5-9
 - 1. PC420/430/FC2205-9
 - 2. PC400/FC2005-9
 - E. Paper is present at the pick-up or delivery sensor at time of power-on or when the Copy Start key is pressed.5-9
- V. MECHANICAL SYSTEM.....5-10
 - A. Pick-Up Roller Assembly.....5-11
 - 1. Detaching the Pick-Up Roller5-11
 - B. Registration Roller Assembly5-14
 - 1. Detaching the Registration Roller Assembly.....5-14
 - C. Removing the Separation Pad5-15

CHAPTER 6 FIXING SYSTEM

- I. OUTLINE OF OPERATIONS6-1
 - A. Outline6-1
 - B. Controlling the Fixing Heater Temperature.....6-3
 - C. Controlling the Supply Power to the Fixing Heater6-3
 - D. Protection Mechanisms6-5
- II. MECHANICAL SYSTEM.....6-6
 - A. Fixing Assembly.....6-7

- | | |
|---|--|
| 1. Construction.....6-7 | 3. Removing the Fixing Upper Unit6-9 |
| 2. Detaching the Fixing Assembly6-7 | 4. Detaching the Pressure Roller6-11 |

CHAPTER 7 EXTERNALS/AUXILIARY MECHANISMS

- | | |
|--|--|
| I. POWER SUPPLY7-1 | 5. Detaching the Bottom Cover7-8 |
| A. Outline7-1 | B. Copyboard Assembly.....7-9 |
| B. Power Supply PCB7-2 | 1. Detaching the Copyboard Cover7-9 |
| C. Protection Mechanism for Power Supply Circuit.....7-2 | 2. Detaching the Copyboard ..7-9 |
| II.MECHANICAL SYSTEM7-3 | C. DC Controller/DC Power Supply PCB.....7-11 |
| A. External Covers7-4 | 1. Detaching the DC Controller/DC Power Supply PCB.....7-11 |
| 1. Detaching the Control Panel Cover7-4 | 2. Points to Note When Installing the Delivery Door Switch .7-13 |
| 2. Detaching the Body Cover7-5 | D. Control Panel PCB.....7-14 |
| 3. Detaching the Top Cover Assembly7-7 | 1. Detaching the Control Panel PCB7-14 |
| 4. Detaching the Delivery Assembly Cover.....7-7 | |

CHAPTER 8 INSTALLATION

- | | |
|---|-------------------------------------|
| I. SELECTING THE SITE8-1 | III. RELOCATING THE MACHINE8-5 |
| II. UNPACKING AND INSTALLATION8-2 | |

CHAPTER 9 MAINTENANCE AND SERVICING

- | | |
|---|--|
| I. PERIODICALLY REPLACED PARTS9-1 | B. Storing and Handling Unsealed Cartridges9-3 |
| II. DURABLES.....9-1 | 1. Storing Unsealed Cartridges9-3 |
| III. PERIODICAL SERVICING9-1 | 2. Handling the Cartridge.....9-3 |
| IV. NOTES ABOUT CARTRIDGE9-2 | |
| A. Storing Sealed Cartridges.....9-2 | |

CHAPTER 10 TROUBLESHOOTING

- | | |
|---|---|
| I. MAINTENANCE AND INSPECTION10-3 | ADJUSTMENTS10-5 |
| A. Image Adjustment Basic Procedure10-3 | A. Mechanical.....10-5 |
| B. Points to Note10-4 | 1. Image Leading Edge Non-Image Width (position of white paint on back of glass).....10-5 |
| II. STANDARDS AND | 2. Image Leading Edge Margin |

	(point of detection for registration).....	10-5		(cross feed direction).	10-20
B.	Electrical	10-6	13.	The back of the copy is soiled.	10-20
1.	Adjusting the Intensity (VR604)	10-6	14.	The copy has faulty fixing.	10-21
2.	Adjusting the AE Mechanism (VR602, VR603)	10-8	15.	The copy has faulty leading edge registration (blank area much too wide).	10-21
III.	IMAGE TROUBLESHOOTING	10-11	16.	The copy has faulty leading edge registration (blank area too wide).	10-21
A.	Making Initial Checks	10-11	17.	The copy has faulty leading edge registration (no blank area).	10-21
1.	Site Environment.....	10-11	18.	The copy has a blurred image.	10-22
2.	Checking the Documents	10-11	19.	The copy is foggy (cross feed direction).	10-22
3.	Checking the Copyboard Cover and Copyboard Glass for Dirt and Scratches	10-12	20.	The copy has poor sharpness (focus).....	10-22
4.	Checking the Lens Array for Dirt	10-12	21.	The copy is blank.....	10-23
5.	Checking the Transfer Charging Roller	10-12	22.	The copy is solid black...10-23	
6.	Checking the Feeding Assembly	10-12	IV.	TRUBLESHOOTING	
7.	Checking the Copy Paper	10-12		MALFUNCTIONS.....	10-24
8.	Checking the Durables ..	10-12	A.	Troubleshooting Malfunctions	10-24
9.	Others	10-14	1.	8√(self diagnosis; PC400/FC200).....	10-24
B.	Samples of Image Faults	10-16	2.	E0	10-24
C.	Troubleshooting by Image Fault	10-17	3.	E2	10-25
1.	The copy is too light (halftone areas only).	10-17	4.	E6	10-25
2.	The copy is too light (dark areas as well).....	10-17	5.	E9	10-26
3.	The copy is too light (extremely light overall)..	10-17	6.	AC power is absent.....	10-26
4.	The copy has uneven density (darker at front).	10-18	7.	Pick-up fails.	10-27
5.	The copy has uneven density (lighter at front).	10-18	8.	The scanning lamp fails to go ON.	10-27
6.	The copy is foggy (overall).	10-18	9.	The main motor fails to rotate.	10-28
7.	The copy is foggy (paper feed direction).	10-19	10.	The copyboard fails to move.	10-28
8.	The copy has dark lines (paper feed direction, relatively narrow).	10-19	11.	8√(paper feeding normally)	10-29
9.	The copy has dark lines (paper feed direction, thin).	10-19	12.	8√(at time of jam)	10-29
10.	The copy has white spots (paper feed direction).....	10-19	13.	The fixing heater fails to operate.....	10-29
11.	The copy has white lines (paper feed direction).....	10-19	V.	TRUBLESHOOTING PAPER	
12.	The copy has white spots	10-19		FEED PROBLEMS	10-30
			A.	Copy Paper Jams	10-30
			1.	Pick-Up Assembly.....	10-31
			2.	Separation/Feeding Assembly	10-31
			3.	Fixing/Delivery Assembly	10-32

B. Feeding Faults	10-33		
1. Double Feeding	10-33		
2. Wrinkles	10-33		
VI. FUNCTIONS AND ARRANGEMENT OF ELECTRICAL PARTS	10-34		
A. Sensors and Solenoids	10-34		
B. Switches	10-35		
C. Lamp, Heater, Motor, and Others			
		10-36
		D. Printed Circuit Board (PCB)	10-37
		E. Variable Resistors (VR) and	
		Check Pins by PCB	10-38
		1. DC Controller/DC Power	
		Supply PCB	10-38
		2. Control Panel PCB.....	10-39
		VII. SELF DIAGNOSIS	10-40

APPENDIX

A. GENERAL TIMING CHART	A-1	C. GENERAL CIRCUIT DIAGRAM...	A-5
B. SIGNALS/ABBREVIATIONS LISTA-	A-3	D. SPECIAL TOOLS TABLE	A-7
1. Signals.....	A-3	E. SOLVENTS/OILS TABLE	A-8
2. Abbreviations.....	A-4		

CHAPTER 1

GENERAL DESCRIPTION

This chapter outlines the machine's specifications and how it may be operated.

I. FEATURES	1-1	D. Add Paper Indicator	1-11
II. SPECIFICATIONS	1-2	E. Replacing the Cartridge	1-11
III. NAMES OF PARTS	1-4	F. Changing the Density	1-14
A. External View	1-4	G. Cleaning.....	1-14
B. Cross Section	1-5	H. When Not Using the Copier for a Long Time	1-16
IV. OPERATION	1-6	V. IMAGE FORMATION	1-17
A. Control Panel	1-6	A. Outline.....	1-17
B. Making Copies	1-8		
C. Jam Indicator.....	1-11		

Blank Page

I. FEATURES

1. **Direct charging.**

The charging roller directly charges paper, significantly reducing ozone emission.

2. **Auto power-off.**

The copier shuts off automatically when left alone for about 5 minutes after the last copy operation.

3. **Quick start.**

The copier's wait time is 0 second, always ready for quick copying work.

4. **Cartridge type.**

The core of the copier (photosensitive drum, toner case, charging roller, developing assembly, and cleaning assembly) is integrated into a single cartridge. The user need no more than replace the cartridge and perform simple cleaning to maintain the copier in top condition.

5. **Variety of copy effects.**

In addition to black toner, the user has a choice of several colors. Taking advantage of overlay copying, various copy effects may be obtained through mere replacement of the cartridge.

6. **Compact and light.**

The copier is compact and light, providing good portability. It can easily substitute as a personal copier.

7. **Multifeeding (PC420/430/FC220).**

A stack of copy paper may be placed on the pick-up tray. A press on the Copy Start key is all it takes to generate multiple copies.

II. SPECIFICATIONS

	Item	PC400/FC200	PC420/430/FC220
Type	Body	Portable (w/ grips)	
	Copyboard	Moving	
	Light source	Tungsten lamp of fuse type	
	Lens	Lens array	
	Photosensitive medium	OPC (24 dia.)	
System	Copying	Indirect electrostatic	
	Charging	Roller (direct charging)	
	Exposure	Slit (moving copyboard)	
	Copy density adjustment	Manual	Automatic (AE) or Manual
	Development	Dry	
	Pick-up	Manual tray	Multifeeder
	Separation	Curvature + Static eliminator	
	Cleaning	Blade	
	Fixing	Plane heater	
Performance	Document type	Sheet, Book, 3-D object (2 kg/4.4 lb max.)	
	Maximum document size	LTR/A4; LGL*	
	Reproduction ratio	1:1 ($\pm 1.2\%$)	
	Wait time	0 sec (approx.; at 20°C/68°F)	
	First copy	22 sec (LTR)	
	Continuous copying	Not available	1 to 9 copies or F
	Copying speed	4 copies/min (approx.; A4R/LTR-R or smaller)	4 copies/min (A4R/LTR-R or smaller) 3 copies/min (LGL)
	Copy size	A4/LTR; LGL* max.; postcard min.	
	Copy paper type	52 to 128 g/m ² , Tracing paper, Colored paper, OHP film, Postcard (vertical), Labels, Wrapping paper (63 g/m ²)	
	Two-sided copying	<ul style="list-style-type: none"> • Same edge orientation. • Copying on each side no more than twice. 	<ul style="list-style-type: none"> • Paper of 64 to 128 g/m².
	Overlay copying	<ul style="list-style-type: none"> • Paper of 64 to 128 g/m². 	<ul style="list-style-type: none"> • Copying on each side no more than three times.
	Multifeeder tray	—	5 mm deep (about 50 sheets of A4, 80 g/m ²)
	Copy tray	—	9 copies (approx.; A4/LTR, 80 g/m ²)
	Non-image width	2 mm (leading edge) A4: 0 mm (left/right) LTR/LGL: 2 mm (left/right)	
Auto power-off	Available (5 min, approx.)		

*PC430 only.

		Item	PC400/FC200	PC420/430/FC220	
Others	Operating environment	Temperature	7.5° to 32.5°C/45.5° to 90.5°F		
		Humidity	5% to 85%		
		Atmospheric pressure	810.6 hPa to 1013.3 hPa (0.8 to 1 atm)		
	Power supply		Serial numbers	Serial numbers	
		120V, 60Hz	ZTG XXXXX (PC400:WHITE) ZTH XXXXX (PC400:GRAY)	NVD XXXXX (FC220:WHITE) ZTJ XXXXX (PC420:WHITE)	
		230V, 50Hz	RTL/PTQ XXXXX (FC200:WHITE) UTP/UTQ	RTM/PTR XXXXX (FC220:WHITE) PTS XXXXX (FC220:WHITE) PTT XXXXX (FC220:WHITE)	
	Power consumption	Maximum	0.7 kW or less		
		Standby	0.1 W (approx.; 5 min; reference only)		
		Continuous	0.2 kWh (reference only)		
	Noise	Copying	71 dB	Sound power level by ISO	
		Standby	—		
	Ozone	0.01 ppm or less (average over 8 hr)			
	Dimensions	Width	14.1 in./359 mm		
		Depth	15.7 in./402 mm		
		Height	4.1 in./108 mm		
	Weight (including cartridge)	16.6 lb/7.4 kg (approx.)			
	Consumables	Copy paper	Keep wrapped to protect against humidity.		
Cartridge		See CHAPTER 9.			

Specifications subject to change without notice.

III. NAMES OF PARTS

A. External View

(PC420/430/FC220)

(PC400/FC200)

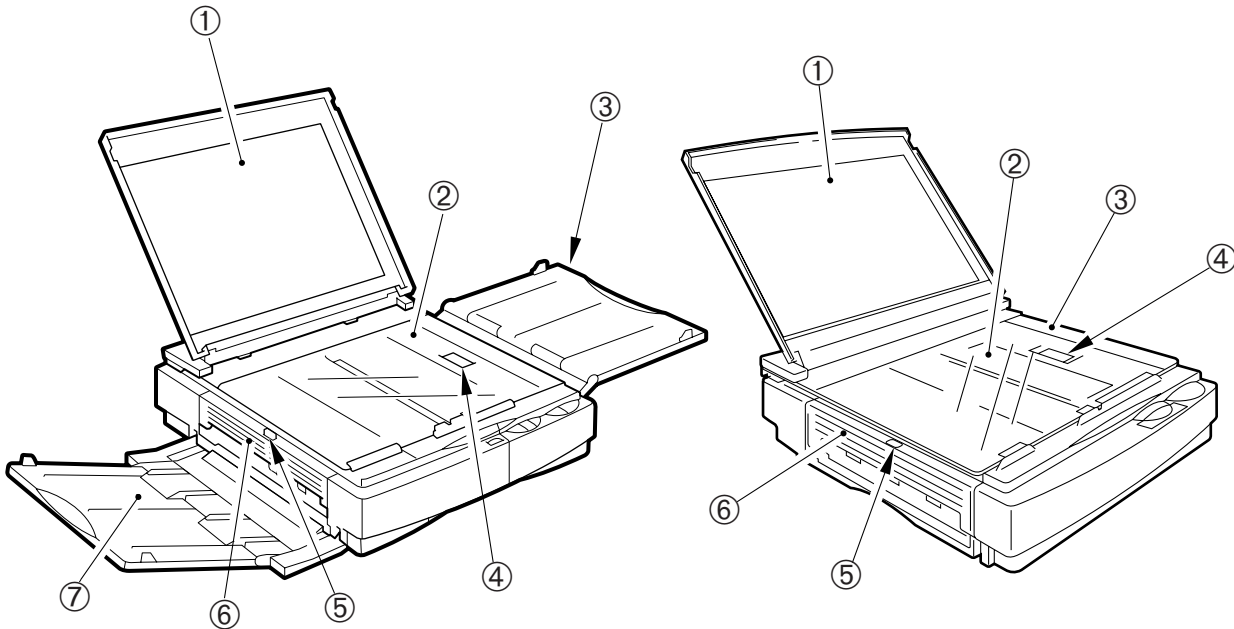

- ① Copyboard cover
- ② Copyboard glass
- ③ Pick-up tray
- ④ Open/Close button

- ⑤ Delivery assembly cover open/close button
- ⑥ Delivery assembly cover
- ⑦ Copy tray

Figure 1-301A

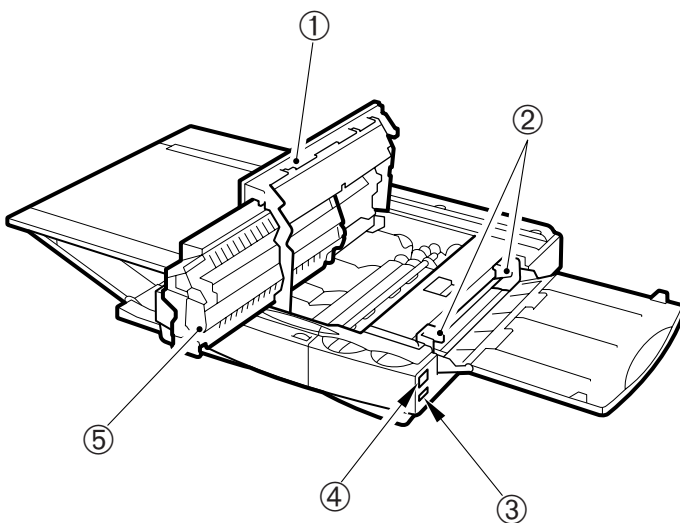

- ① Upper cover
- ② Pick-up guide
- ③ Density correction switch
- ④ Power switch
- ⑤ Cartridge

Figure 1-302A

B. Cross Section

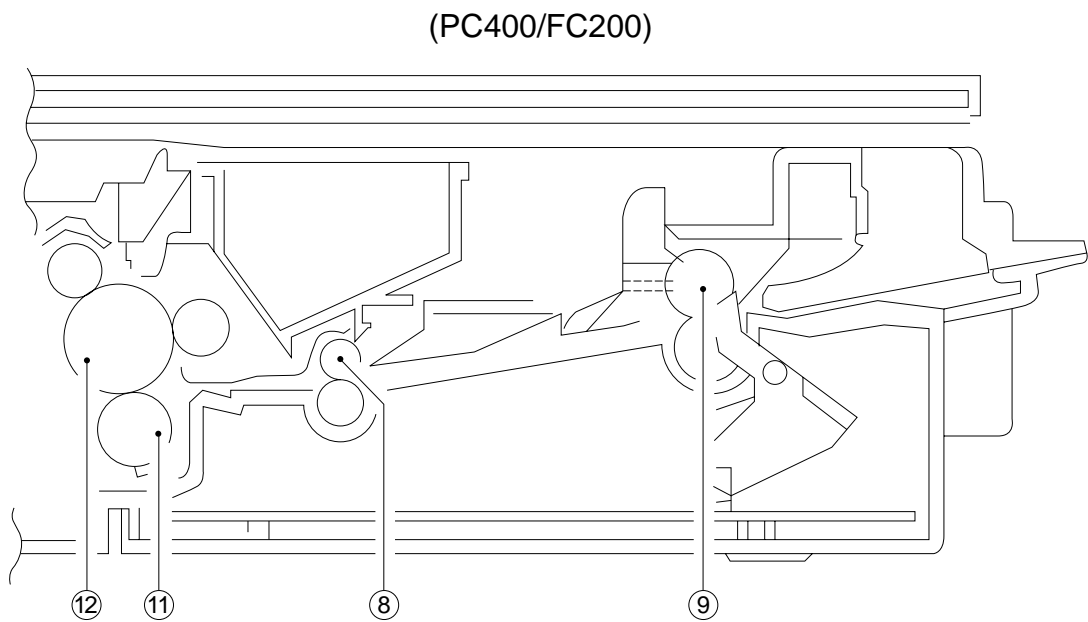
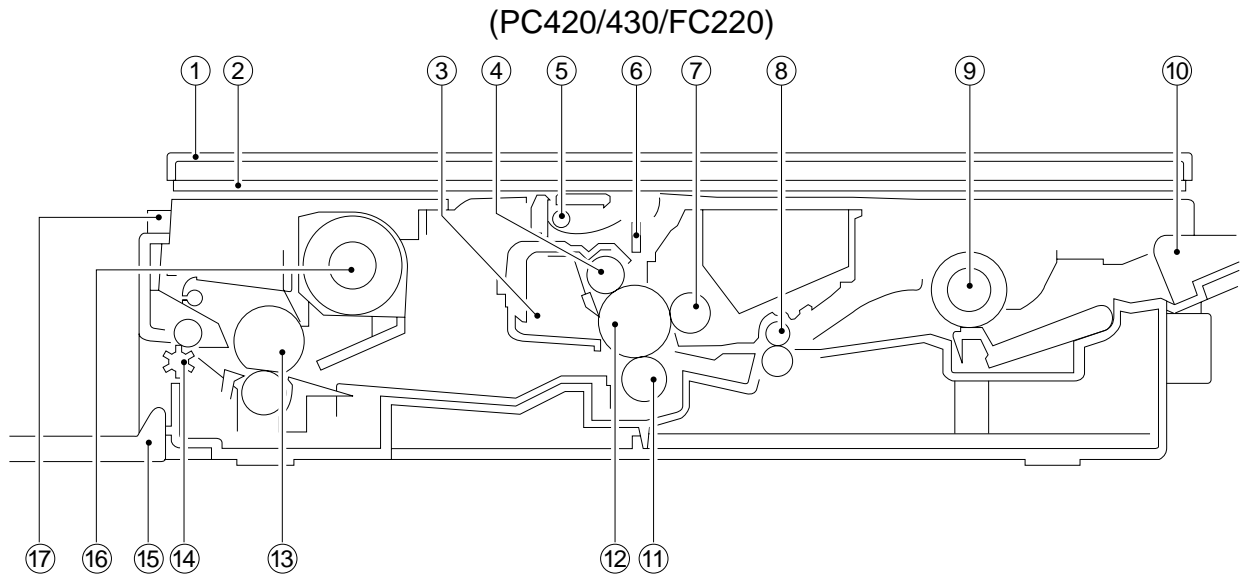

- | | |
|---------------------------|--|
| ① Copyboard cover | ⑩ Pick-up tray |
| ② Copyboard glass | ⑪ Transfer charging roller |
| ③ Cleaning assembly | ⑫ Photosensitive drum |
| ④ Primary charging roller | ⑬ Fixing assembly |
| ⑤ Scanning lamp | ⑭ Delivery roller |
| ⑥ Lens array | ⑮ Delivery tray |
| ⑦ Developing cylinder | ⑯ Heat exhaust fan |
| ⑧ Registration roller | ⑰ Delivery assembly cover
open/close button |
| ⑨ Pick-up roller | |

Figure 1-301B

IV. OPERATION

A. Control Panel

1. PC420/430/FC220

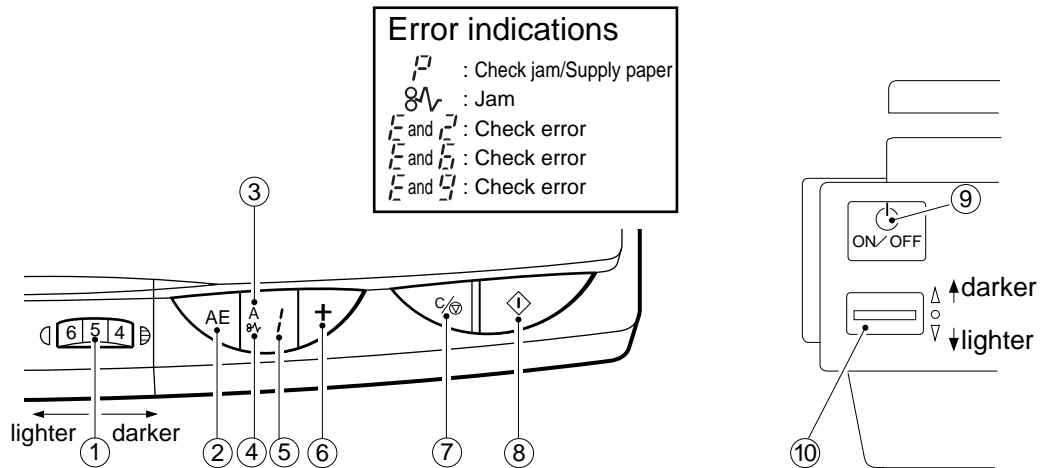

Figure 1-401A

- ① Density Control Dial
- ② AE key
 - Press it to select/deselect AE (automatic exposure) mode.
- ③ AE Indicator
 - 'A' goes ON when AE mode is selected.
 - 'A' goes OFF when AE mode is deselected.
- ④ Jam Indicator
 - Flashes when paper jams inside the copier.
- ⑤ Copy Count Indicator
 - Displays the number of copies entered by pressing the Copy Count Set key.
 - The count decreases for each copy made; the initial number is displayed after the last copy has been made.
 - 'P' is displayed to indicate pick-up failure or absence of paper; 'E' is displayed in response to an error found by self diagnosis.
- ⑥ Copy Count Set Key
 - Each press on the key increases the copy count (up to 9).
 - A press while '9' is displayed causes 'P' to appear, indicating all sheets on the pick-up tray will be used for continuous copying.
- ⑦ Clear/Stop Key
 - During continuous copying, the key serves as a Copy Stop key; the operation stops after finishing the ongoing copy.
 - During standby, the key serves as a Clear key, setting the copy count to '0'.
- ⑧ Copy Start Key
- ⑨ Power Switch
- ⑩ Density Correction Switch
 - Switches copy density among three settings (top for darker, bottom for lighter).
 - The density is switched by varying the developing bias.

2. PC400/FC200

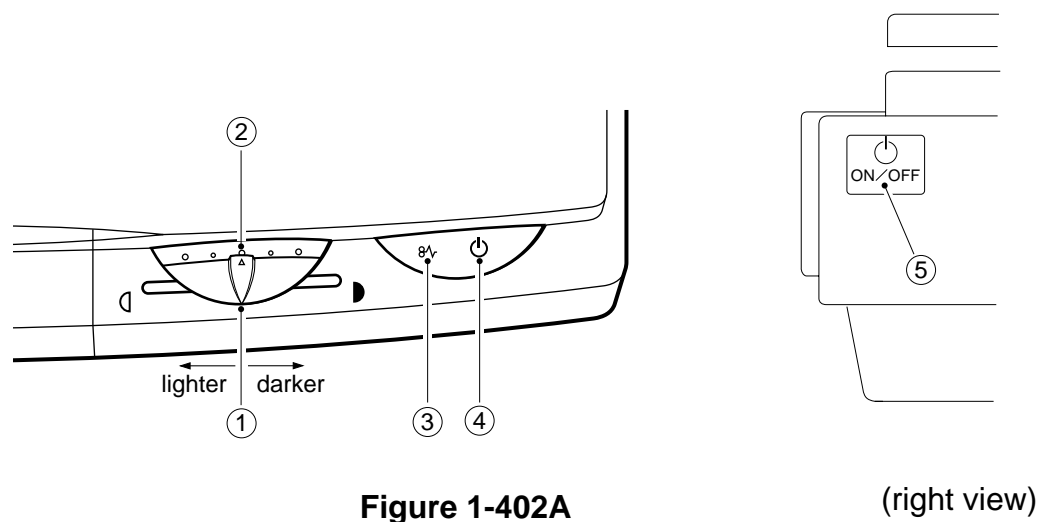

Figure 1-402A

(right view)

- ① Density Control Lever
- ② Density Indicator
- ③ Jam Indicator
 - Flashes when paper jams inside the copier.
 - Goes and remains ON when an error (self diagnosis) occurs in the copier.
- ④ Main Indicator
 - Remains ON when copying is ready.
- ⑤ Power Switch

B. Making Copies

- 1) Switch the copier ON.
 - If necessary, wait until the intensity of the scanning lamp reaches the specified value.
 - The wait time is about 0 second.
 - The copier will shut itself off in about 5 minutes if left alone without key operation.
- 2) Lift the copyboard cover, and place a document face down, along the size index.
 - Place the document so that its center is at ← on the size index (Figure 1-401B); then, close the copyboard cover.

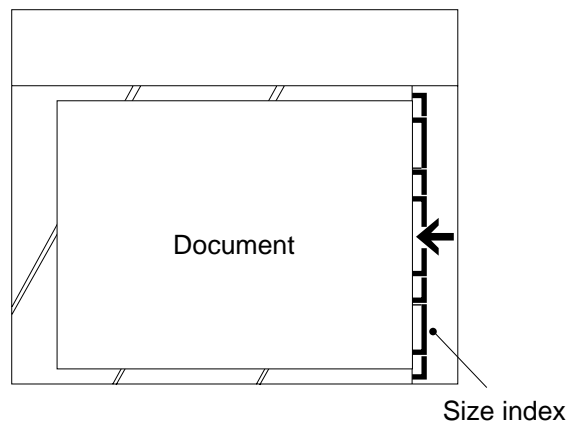

Figure 1-401B

- 3) Adjust the copy density to suit the document.
- 4) Slide the pick-up guide to suit the size of copy paper.
- 5) Set copy paper on the pick-up tray.

PC420/430/FC220

Place a stack of copy paper of a size suited to the document on the pick-up tray; make sure the edges of the sheets are flush.

- The stack may be 5 mm (about 50 sheets of plain paper).

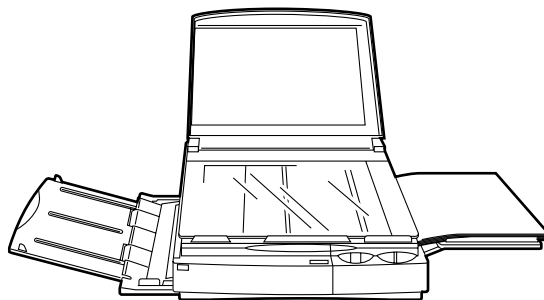

Figure 1-402B

- 6) Set the copy count.

PC420/430/FC220

Set the number of copies to make (1 to 9 or F) using the + key, and check the Copy Count indicator.

- 7) Press the Copy Start key.

PC420/430/FC220

- To stop continuous copying, press the Clear/Stop key; the copier finishes the ongoing copy and stops. The copy count displays the initial count.

Copying on OHP Film

- Set one sheet of film on the pick-up tray for each copy.
 - Depending on the environment of the site, a press on the Copy Start key may not pull the film inside the copier; if this is the case, perform the following:
- 1) Place copy paper under the film; stagger the sheet and film so that the leading edge of the film is about 1 cm behind that of the paper.

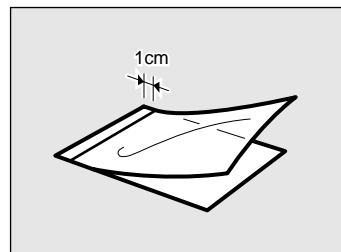

Figure 1-403B

- 2) Hold the trailing edge of the copy paper, and set the sheet and film on the pick-up tray.
- 3) While holding the trailing edge of the copy paper, press the Copy Start key. Remove the paper when the film begins to move into the copier; the paper will no longer serve its purpose.

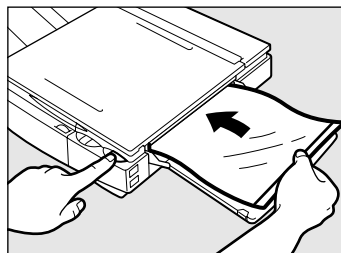

Figure 1-404B

Note:

Take away each OHP film delivered to the copy tray.

Manual Feeding

PC400/FC200

- 1) Set a document on the copyboard.
- 2) Adjust the Density Control lever to suit the document.
- 3) Slide the pick-up guide to suit the size of copy paper.
- 4) Insert copy paper along the pick-up guide.
 - The copier starts copying operation automatically as soon as it detects paper.
 - To continue copying, insert the next paper when the copyboard starts to return.

Making Two-Sided Copies

- 1) Turn over the copy while maintaining its feeding direction.
 - Make sure that the paper is not moist or curled.
 - Use paper of 64 to 128 g/m² when making two-sided copies.
 - Do not process each side more than twice.

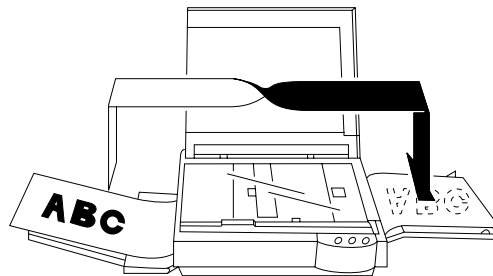

Figure 1-405B

Making Overlay Copies

You can make two- or three-colored copies by replacing the cartridge.

- Use paper of 64 to 128 g/m² when making overlay copies.
- Do not process each side more than three times.

C. Jam Indicator

The Jam indicator starts to flash when paper jams inside the copier.

- Take care not to tear the paper when removing it; otherwise, be sure to remove all pieces of paper.
- 1) Move the copyboard to the left until it stops.
 - 2) Press the open/close button, and open the top cover.
 - 3) Remove the jam.
 - If the jam is in the pick-up or fixing assembly, hold the edge of the paper with both hands, and pull it out slowly through the opening of the top cover.
 - If the jam is in the delivery assembly, press the delivery assembly open/close button to open the delivery cover; then, detach the paper from the delivery cover, and pull it slowly in the direction of delivery.
 - 4) Close the top cover and delivery cover; then, move the copyboard to the center.
 - To resume copying, switch the copier ON, set the desired copy count, and set the copy density.

D. Add Paper Indicator

PC420/430/FC220

'P' flashes if you try to make a copy when the pick-up tray has run out of paper.

- 1) Check the pick-up tray for copy paper.
- 2) If no paper is on the tray, place paper.
If a stack of paper is on the tray, remove it first, then place it back after putting its edges flush.
- 3) Press the Copy Start key.
 - 'P' goes OFF, and the remaining number of copies are made.

E. Replacing the Cartridge

1. Time to Replace the Cartridge

When the cartridge is running out of toner, copies tend to show white lines or vertical white spots (Figure 1-401E).

Preface

Thank you for purchasing this Canon copier, its functions and operation. Please read this manual carefully in order to familiarize yourself with its capabilities and functions. After you have read this manual, you will be able to use the copier more effectively.

Canon copier. This manual describes the method of use. It is important to read this manual carefully before using the copier with its capabilities. After you have read this manual, you will be able to use the copier more effectively.

▲ CAUTION:

In this manual, CAUTION is indicated by a triangle symbol. It indicates a procedure or a point to be particularly careful of.

CAUTIONS with this manual. It is important to read this manual carefully before using the copier with its capabilities. After you have read this manual, you will be able to use the copier more effectively.

Figure 1-401E

If white lines or spots appear on copies, replace the cartridge as follows:

- 1) Remove the cartridge from the copier, and rotate it several times as shown in Figure 1-402E.

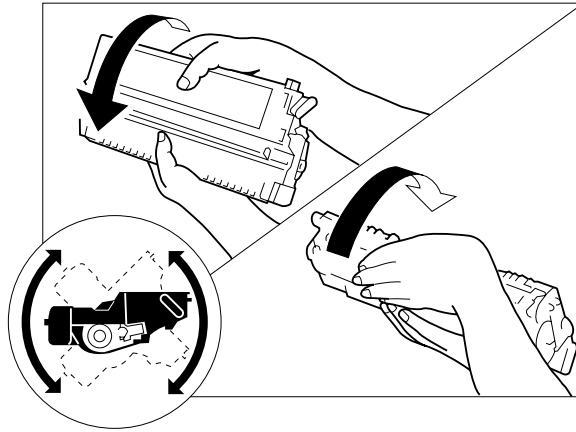

Figure 1-402E

- 2) Set the cartridge back in the copier, and make a copy.
 - a. If the output returns to normal,
 - The cartridge may be used further; advise the user, however, to obtain a spare cartridge.
 - b. If the output fails to return to normal,
 - Replace the cartridge as described below.

2. Replacing the Cartridge

- 1) Move the copyboard to the left until it stops; then, press the open/close button to open the top cover.
- 2) Slide the cartridge out of the copier.
- 3) Hold the cartridge with the Warning label facing up, and rotate it about 90 degrees in both directions.

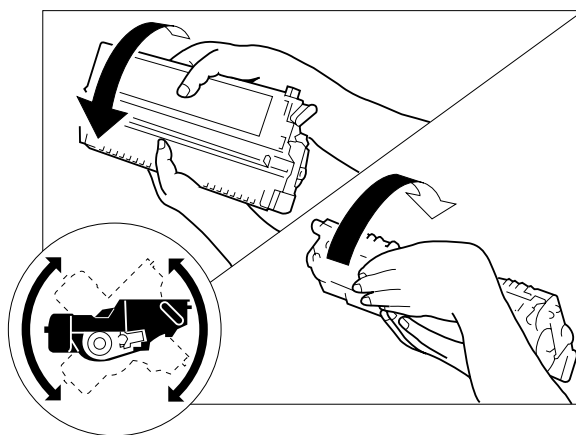

Figure 1-403E

- 4) Detach the tip of the seal attached to the cartridge, and pull it straight out to the front; about 50 cm.

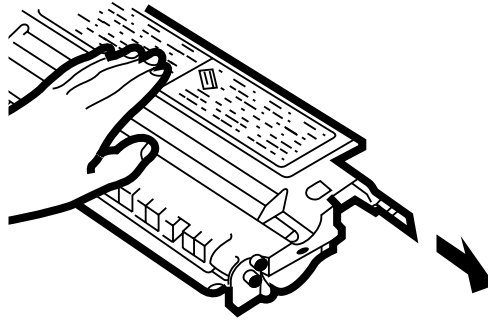

Figure 1-404E

- 5) Hold the cartridge with its Warning label facing the left, and insert it in the copier with care until it butts against the rear.

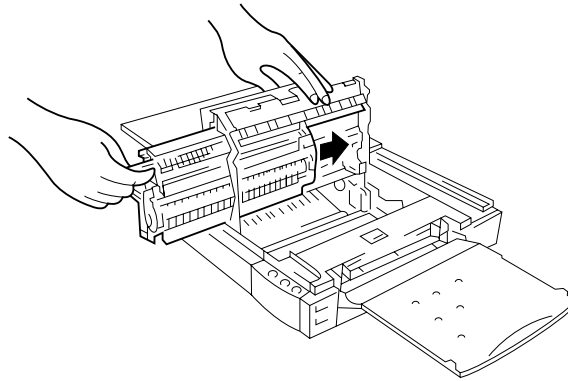

Figure 1-405E

- 6) Close the top cover, and return the copyboard to the center.

Note:

You can replace the black toner cartridge with any color cartridge the same way.

F. Changing the Density

PC420/430/FC220

You have a choice of three settings for automatic density adjustment mode (AE); switch the density if the copy is too dark or too light.

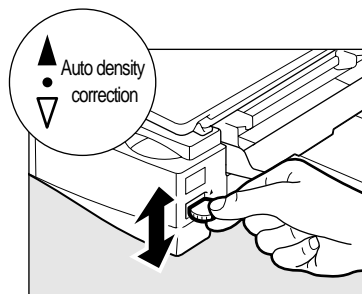
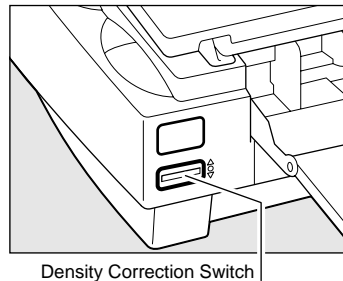

Figure 1-401F

Note:

You can also switch the density among three settings in manual density adjustment mode.

G. Cleaning

Advise the user to clean the following if the copies are soiled.

1. Copyboard Glass/Copyboard Cover

Wipe the part with a moist cloth; then, dry wipe it.

If dirt cannot be removed, wipe the part using mild detergent; then, dry wipe it.

2. Lens Array

- 1) Move the copyboard to the left until it stops.
- 2) Put a cotton wad in the lens array groove, and move it back and forth lightly.

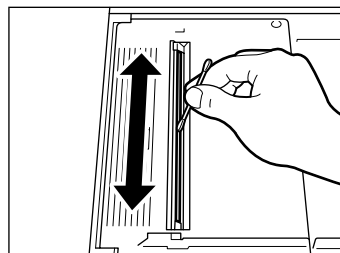
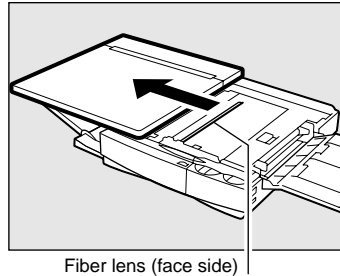

Figure 1-401G

- 3) Open the upper cover, and remove the cartridge.
- 4) Put a flat-tipped cotton wad in the lens array (rear) groove, and move it back and forth.

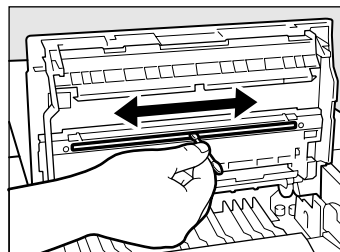

Figure 1-402G

3. Pick-Up Roller

- 1) Open the top cover.
- 2) Dry wipe the pick-up roller while rotating it in pick-up direction with a cloth.

Note:

Do not make copies until the pick-up roller has completely dried.

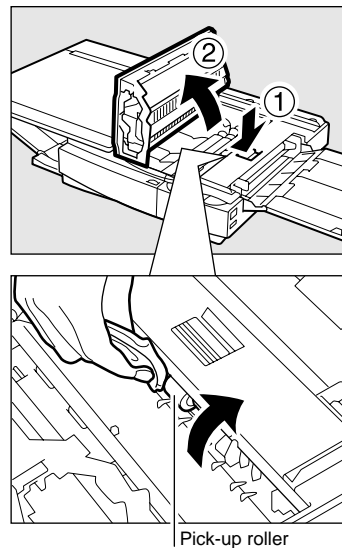

Figure 1-403G

H. When Not Using the Copier for a Long Time

Advise the user to perform the following if she/he does not have any plan to use the copier for a long time.

- 1) Disconnect the power plug.
- 2) Place the copier in a dust-free, sunlight-free place.

V. IMAGE FORMATION

A. Outline

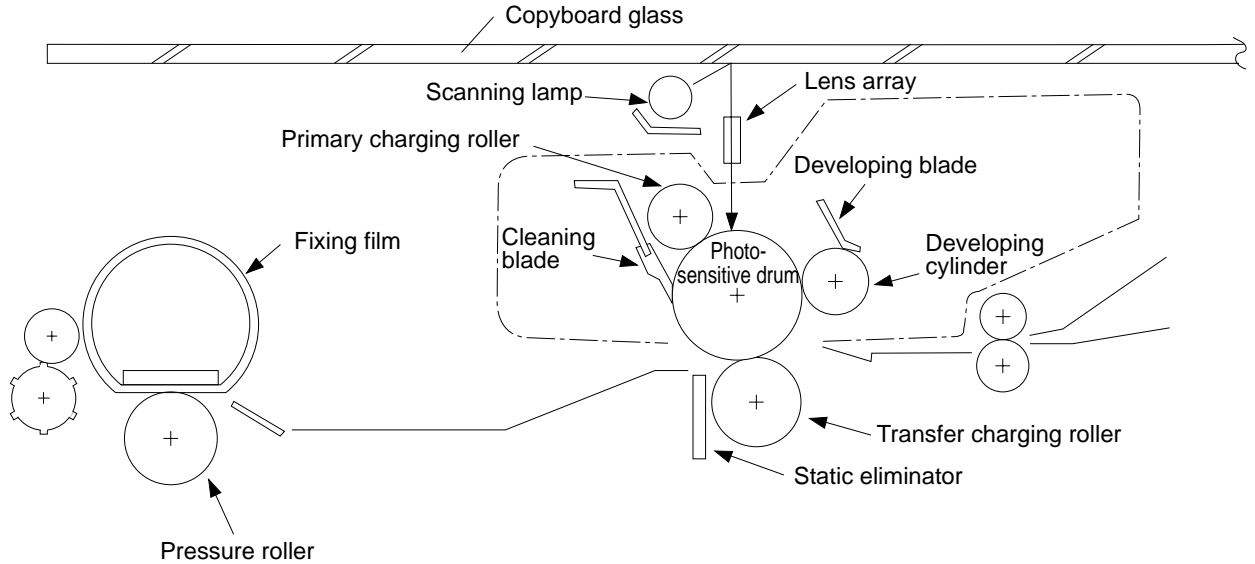

Figure 1-501A

The copier is an indirect photoreprographic system constructed as shown in Figure 1-501A.

The image formation process consists of seven steps as discussed below.

- Step 1 : Primary charging (negative)
- Step 2 : Image exposure
- Step 3 : Development (AC and DC bias)
- Step 4 : Transfer (negative)
- Step 5 : Separation
- Step 6 : Fixing
- Step 7 : Drum cleaning

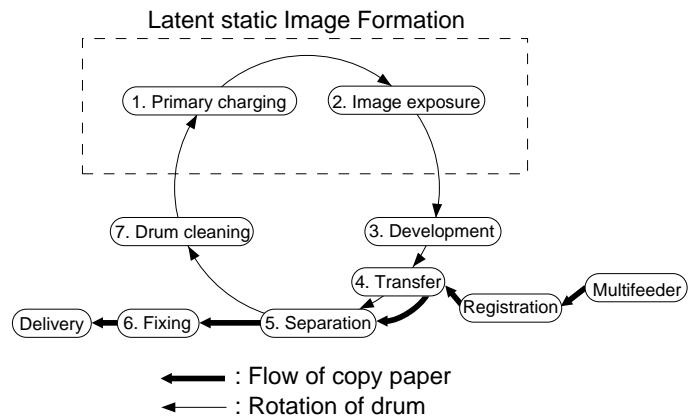

Figure 1-502A

The photosensitive drum has a layer construction: the photoconductive layer on the outside and the conductive aluminum base, inside.

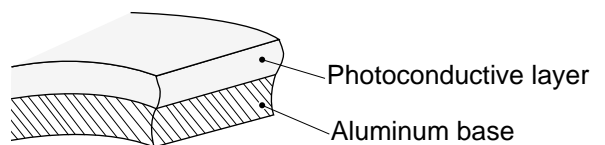

Figure 1-503A

CHAPTER 3

EXPOSURE SYSTEM

This chapter outlines the machine's copyboard drive and scanning lamp control systems in relation to mechanisms and functions, relationship between electrical and mechanical systems, and the timing of operation of respective parts.

I. EXPOSURE/COPYBOARD DRIVE SYSTEM	3-1	B. Operations	3-8
A. Outline of Exposure System ...	3-1	C. Controlling the Intensity of the Scanning Lamp (VR604)	3-8
B. Copyboard Drive System	3-1	III. MECHANICAL SYSTEM.....	3-9
II. Controlling the Scanning Lamp....	3-7	A. Scanning System.....	3-10
A. Outline	3-7	B. Copyboard Drive Assembly...	3-11

Blank Page

I. EXPOSURE/COPYBOARD DRIVE SYSTEM

A. Outline of Exposure System

While the copyboard is moving forward, the scanning lamp (LA1 through LA8) illuminates the document, and the reflected light is projected to the photosensitive drum through the lens array.

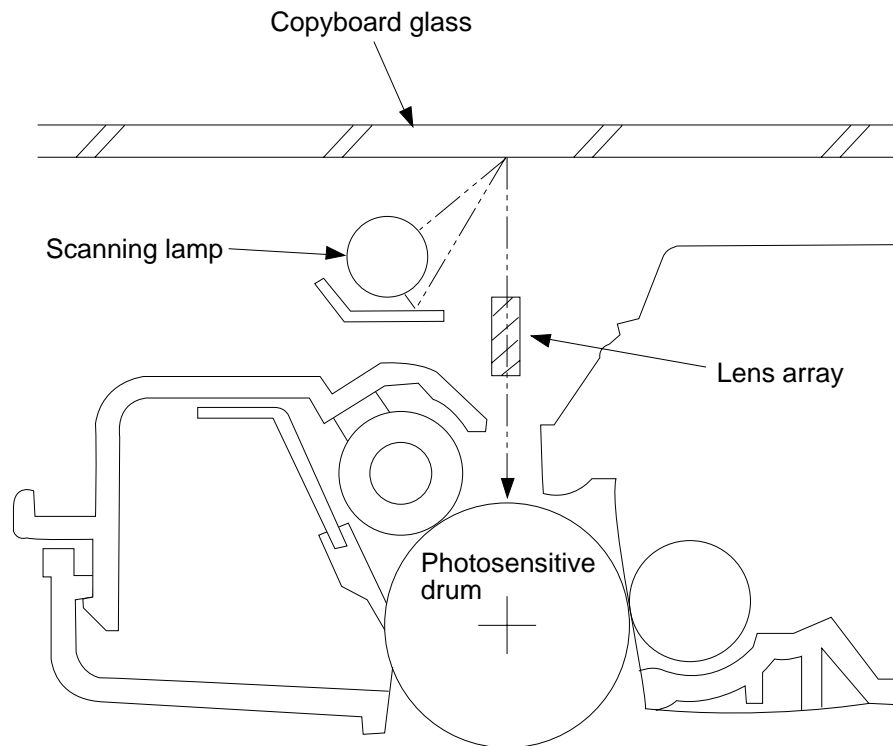

Figure 3-101A

B. Copyboard Drive System

1. Outline

The copyboard is moved forward or in reverse by transmitting the drive of the main motor (M1) to the copyboard drive gear (pinion). Figure 3-101B illustrates the movement of the copyboard.

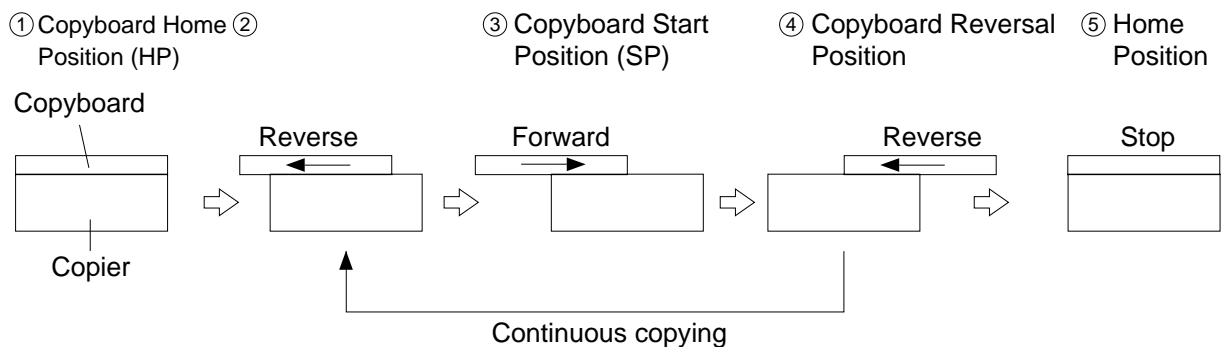

Figure 3-101B Front View

Copyboard position sensor (Q902)		Description	Copyboard position (cams)
Forward	Reverse		
/		<ul style="list-style-type: none"> • Copyboard is at the home position. • Copyboard solenoid goes ON in response to a press on the Copy Start key or insertion of copy paper. 	<p>(front view)</p>
		<ul style="list-style-type: none"> • Copyboard is at the start position. • Copyboard drive solenoid goes OFF. • Scanning lamp ON. 	
	/	<ul style="list-style-type: none"> • The copyboard drive solenoid goes ON about 0.5 second after the Copy Start key is pressed. • AE measurement starts. • Registration roller goes ON (by registration cam). 	
	/	<ul style="list-style-type: none"> • Copyboard is at the reversal position. • Copyboard drive solenoid goes OFF. • After a specific period, copyboard drive solenoid goes ON. • Pick-up solenoid goes ON (continuous copying). • Scanning lamp OFF. 	
/		<ul style="list-style-type: none"> • For the last copy, the copy board drive solenoid goes OFF at the copyboard home position. 	

Continuous copying

Table 3-101B

2. Controlling the Copyboard Drive

The copyboard is controlled for forward, reverse, and stop operations by the copyboard drive solenoid (SL2) and forward/ reverse switching mechanism.

A photosensor (Q902) is provided on the copyboard drive assembly to monitor the position of the copyboard; as the copyboard moves, the cam found under the copyboard pushes the copyboard sensor lever to turn the photosensor ON or OFF.

'E2' is displayed if the copyboard fails to complete its movement within a specific period of time.

In response to the signal from Q902, the DC controller controls the timing for paper transport and the movement (forward, reverse, stop) of the copyboard; see Table 3-101B.

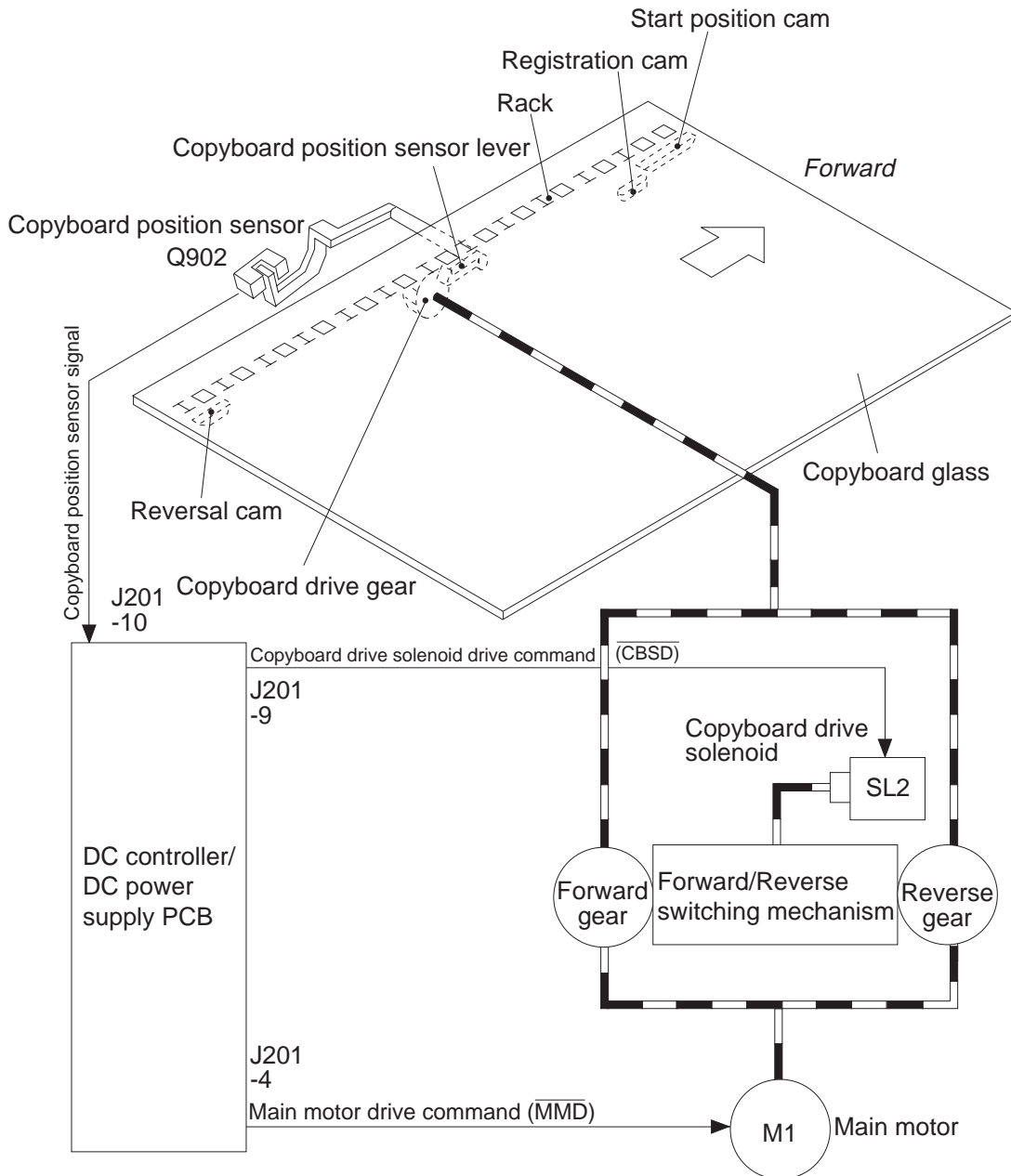

Figure 3-102B Front View

3. Mechanism of Copyboard Drive Assembly

The forward gear and reverse gear are rotating in the direction of the arrow (Figure 103B) while the main motor (M1) is operating.

The forward/reverse switching mechanism engages with either the forward gear or the reverse gear depending on the orientation of the copyboard position sensor lever and the state (ON/OFF) of the copyboard drive solenoid (SL2) operated by the start position cam or reversal cam; when not engaged, the mechanism is said to be free, and the copyboard can be moved by hand.

The above mechanism is used to move the copyboard forward and reverse or to stop it.

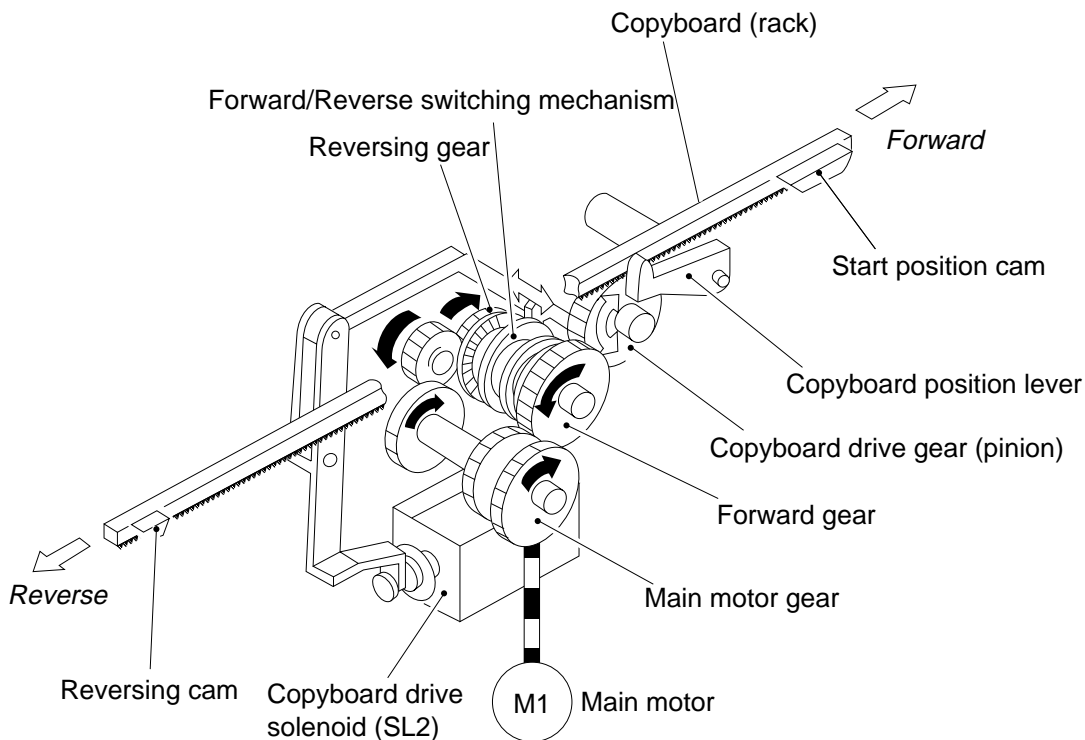

Figure 3-103B

		Copyboard position sensor lever	
		Down	Up
Copyboard drive solenoid (SL2)	ON	forward	reverse
	OFF	stop (free)	

Note:

- i. The direction (forward/reverse) is switched when the copyboard drive solenoid is OFF.
- ii. The direction of the drive is maintained while the copyboard drive solenoid is ON.

Table 3-102B

a. Stopping the Copyboard

Causing the copyboard drive solenoid (SL2) to go OFF frees both forward and reverse gears so that the copyboard remains stationary.

At the time, the copyboard may be moved to the right or left by hand.

b. Moving the Copyboard in Reverse

When SL2 goes ON while the main motor is operating, the forward/reverse switching mechanism engages with the reverse gear, and the reverse gear rotates in the direction of the arrow, causing the copyboard to move in reverse.

The copyboard moves in reverse about two times as fast as when it moves forward owing to the difference in the gear ratio.

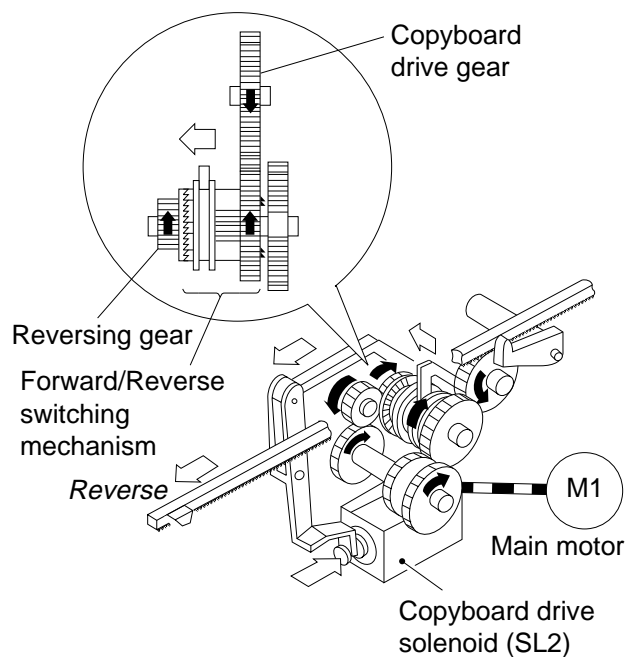

Figure 3-104B

c. Moving the Copyboard Forward

When the copyboard has moved in reverse and is positioned as shown in Figure 3-105B, the start position cam pushes down the copyboard position sensor lever. When SL2 goes ON in this position, the forward/reverse switching mechanism moves to the position shown in the figure, causing the forward/reverse switching mechanism to engage with the forward gear; as a result, the forward gear rotates in the direction of the arrow, moving the copyboard forward.

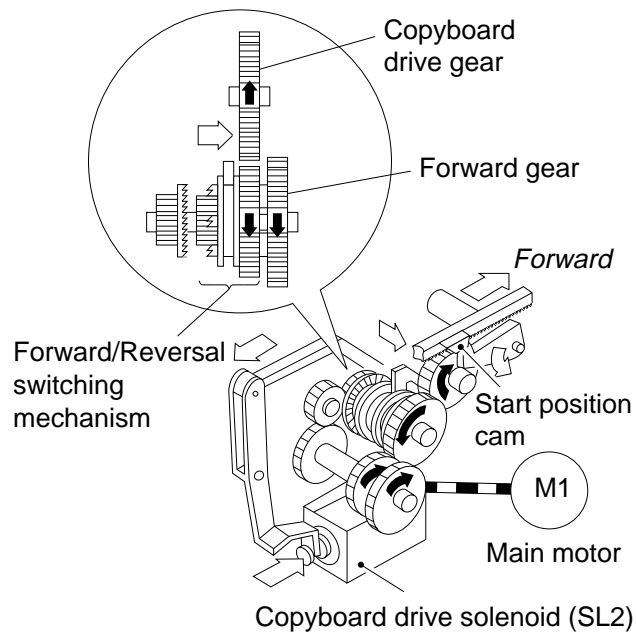

Figure 3-105B

II. Controlling the Scanning Lamp

A. Outline

Figure 3-201A shows the circuit that controls the scanning lamp (fuse lamp), and the circuit has the following functions:

- Turns the scanning lamp ON and OFF.
- Controls the intensity of the scanning lamp.

An intensity sensor (PD601) is provided to ensure that the original will be illuminated after the intensity of the scanning lamp has stabilized.

The intensity of the scanning lamp is checked by the lamp intensity detection signal (LID) to make sure that the intensity has reached the specified value.

In addition, a rush current protection circuit is provided to prevent rush current occurring when the lamp turns on.

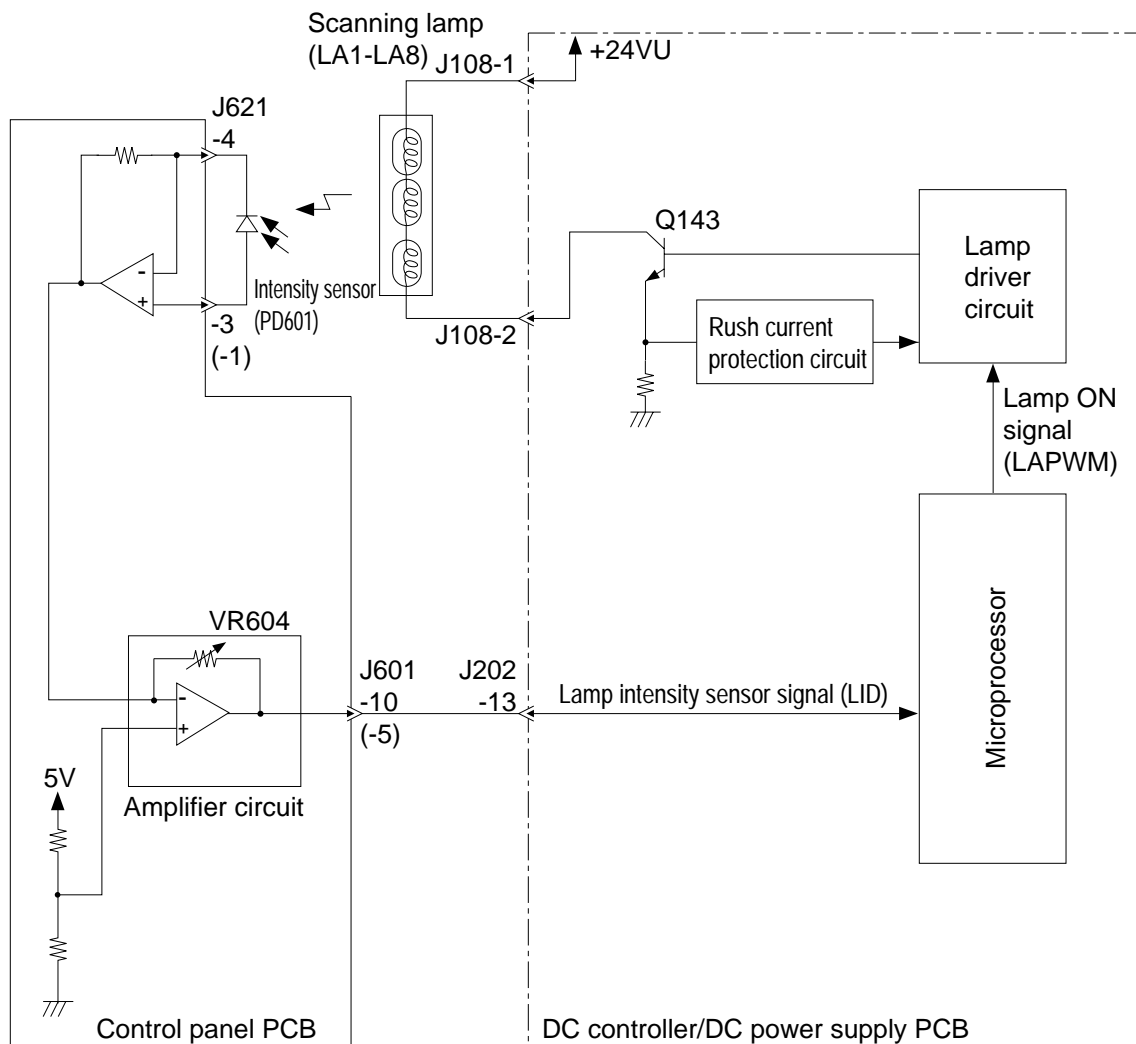

The number within parentheses represents the PC400/FC200.

Figure 3-201A

B. Operations

1. Turning the Scanning Lamp ON and OFF

- Square waves of the LAPWM command corresponding to the output of the amplifier circuit are generated to the lamp driver circuit. (Q143 ON)

→ Current flows into the filament of the lamp, causing the fluorescent lamp to go ON at high frequency.

2. Controlling the Intensity of the Scanning Lamp

- If the intensity of the lamp is low when the lamp goes ON,

→ Initial power of the intensity sensor PD601 is low.

→ Output voltage of the amplifier circuit is high.

→ Duty ratio (H) of the output of the microprocessor (LAPWM command) grows high.

→ Current flowing to the lamp increases.

- If the intensity of the lamp is high when the lamp goes ON,

→ Initial power of the intensity sensor PD601 is high.

→ Output voltage of the amplifier circuit is low.

→ Duty ratio (H) of the output of the microprocessor (LAPWM command) grows low.

→ Current flowing to the lamp decreases.

- If the microprocessor finds out that the scanning lamp has remained on for 2 min at such times as not prescribed, it activates the self diagnostic mechanism; the results are indicated by 'E6' for the PC420/430/FC220 and 'JAM' for the PC400/FC200.

C. Controlling the Intensity of the Scanning Lamp (VR604)

You must adjust the intensity of the lamp if you have replaced the scanning lamp unit, intensity sensor or control panel PCB; see p.10-6.

Note:

You must adjust the AE mechanism after adjusting the intensity.
(PC420/430/FC220)

III.MECHANICAL SYSTEM

Here, the copier is discussed in terms of its mechanical characteristics and operation and how to disassemble and assemble it.

Be sure to observe the following for disassembly/assembly work:

1. ▲ Disconnect the power cord for safety before disassembly or reassembly work.
2. Unless otherwise noted, reassembly is the reverse of disassembly.
3. Group the screws by type (length and diameter) and location.
4. One of the mounting screws used on the rear cover is provided with a washer to protect against static electricity. Be sure to keep the washer with the screw when mounting the cover.
5. The fixing screw for the grounding wire and varistors is fitted with a washer to ensure electric continuity; be sure to use the washer for reassembly.
6. If possible, avoid operating the machine with any of its parts removed.

A. Scanning System

1. Detaching the Scanning Lamp Unit

- 1) Detach the top cover assembly.
- 2) Disengage the two hooks ① and pins ②, and detach the lamp unit ③.

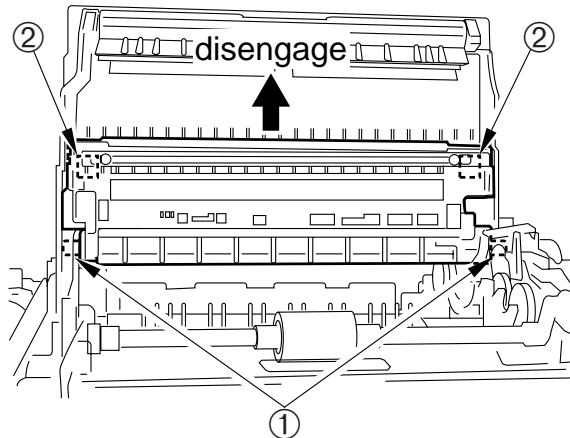

Figure 3-301A

Caution:

The scanning lamp is adjusted at the factory with high precision to ensure the best intensity of light; if necessary, replace it as part of the scanning lamp unit; see Figure 3-302A.

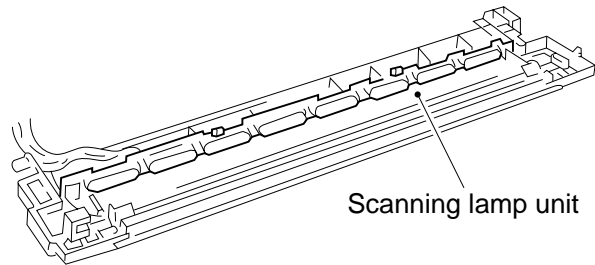

Figure 3-302A

B. Copyboard Drive Assembly

1. Detaching the Copyboard Drive Assembly

- 1) Take out the fixing assembly.
- 2) Remove the screw and remove the grounding wire ①; remove the screw, and remove the motor rotation detecting PCB ②; then, disconnect the four connectors ③.

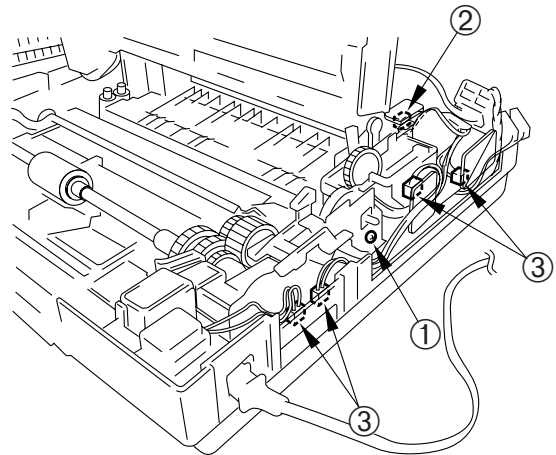

Figure 3-301B (rear view)

- 3) Remove the screw ④, and detach the cartridge support ⑤.

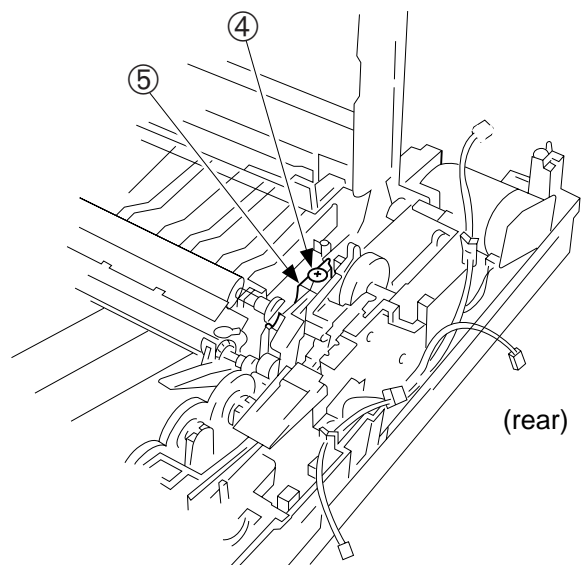

Figure 3-302B

Note:

Take extra care not to damage the teeth of the gear when lifting the copyboard drive assembly.

- 4) Remove the four screws (⑤, M4X8, yellow; ⑥, M3X6, white), and detach the copyboard drive assembly ⑦ as if to lift it.

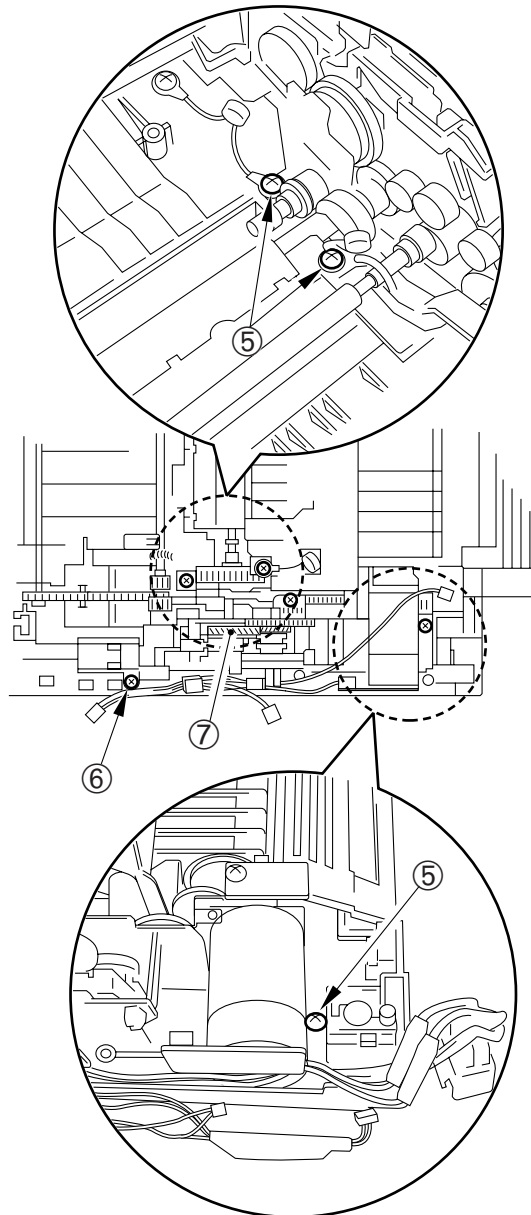

Figure 3-303B

CHAPTER 2

BASIC OPERATION

This chapter outlines the machine's basic mechanisms and functions, relationship between electrical and mechanical systems, and the timing of operation of respective parts.

I. BASIC OPERATION	2-1	D. Main Motor Control Circuit	2-5
A. Outline	2-1	E. Inputs to DC Controller	2-6
B. Outline of Electrical Circuit.....	2-2	F. Outputs from DC Controller	2-8
C. Basic Sequence of Operations (A4, 2 copies).....	2-3		

Blank Page

I. BASIC OPERATION

A. Outline

The copier can be divided into four functional blocks: pick-up/feeding, exposure, image formation, and control blocks.

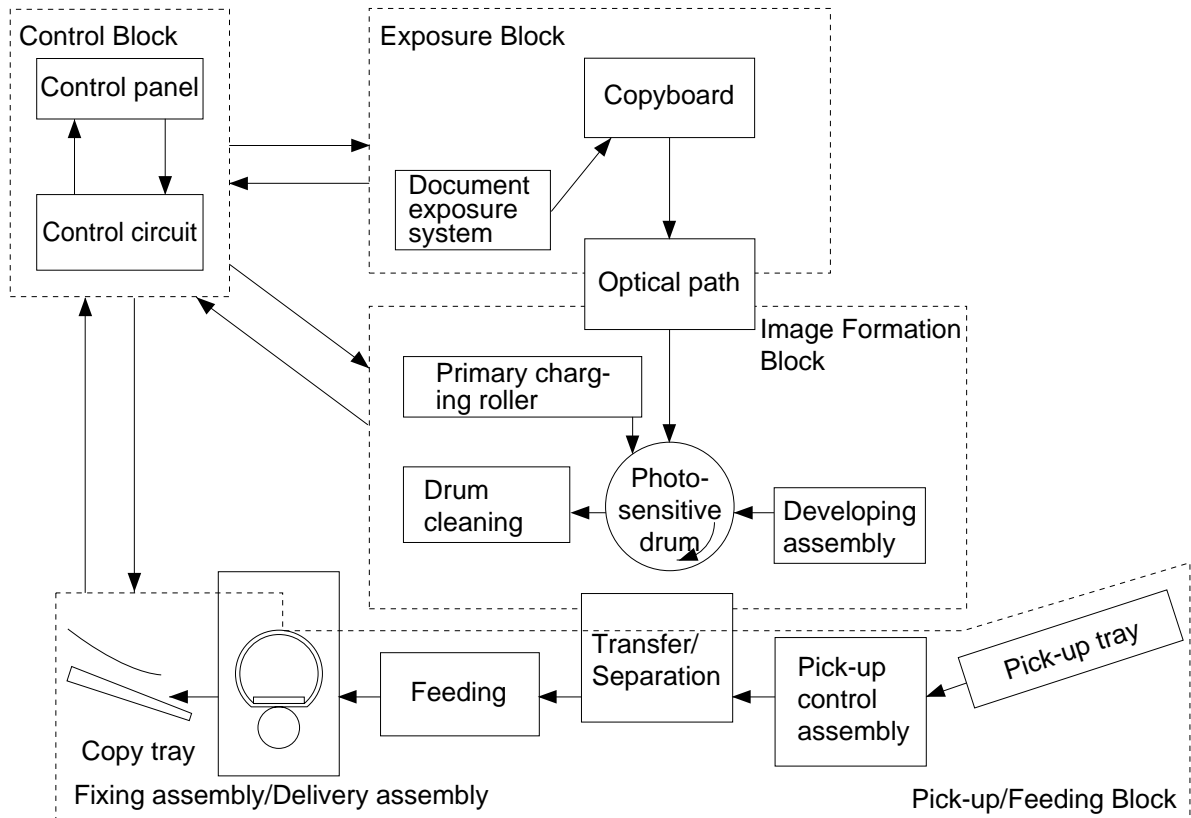

Figure 2-101A

B. Outline of Electrical Circuit

The copier's main electrical mechanisms are controlled by the microprocessor on the DC controller/DC power supply PCB. According to the program stored in advance, the microprocessor reads input signals from the control keys, and generates signals to drive such loads as motors, solenoids, and lamps, as necessary.

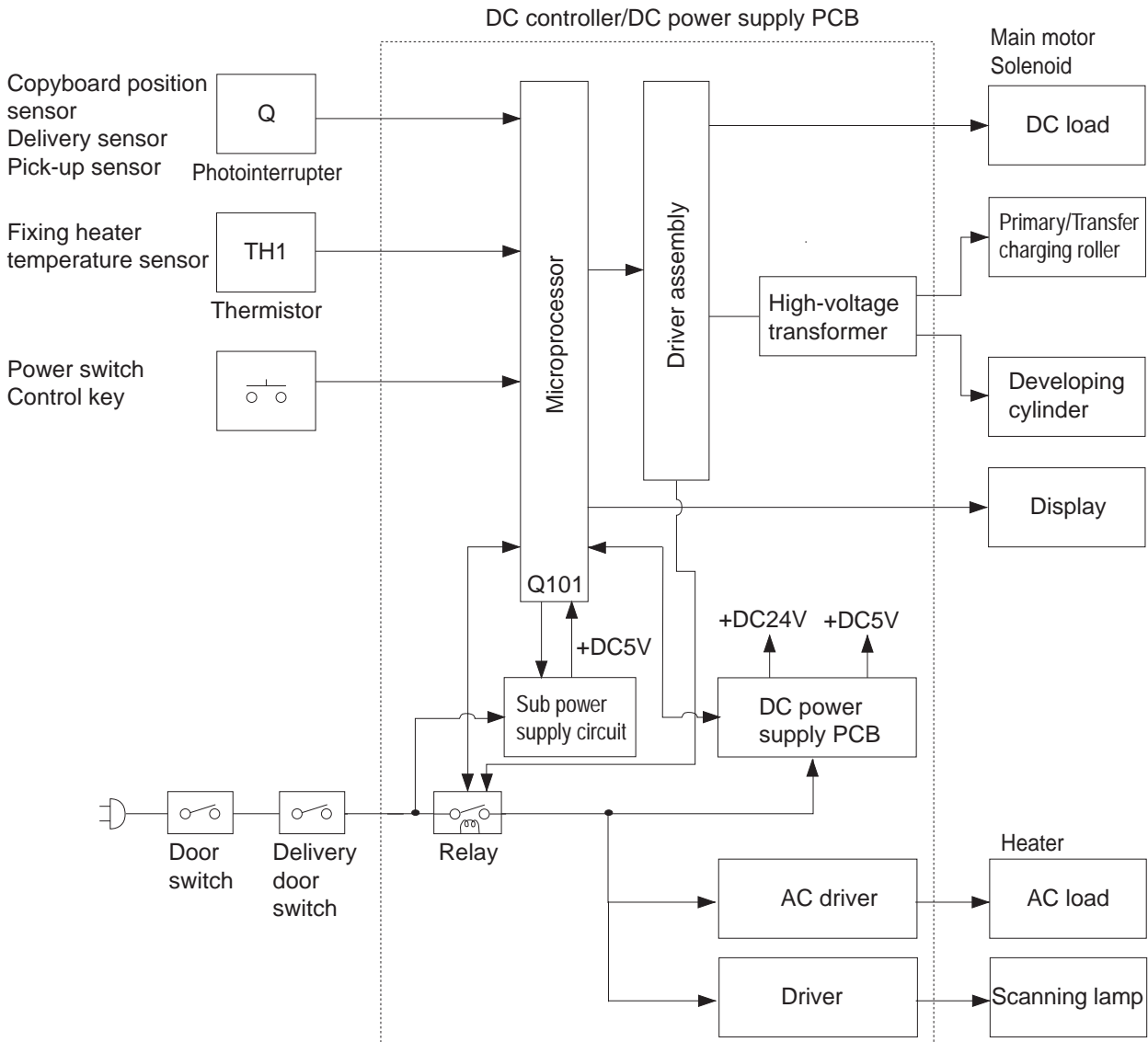
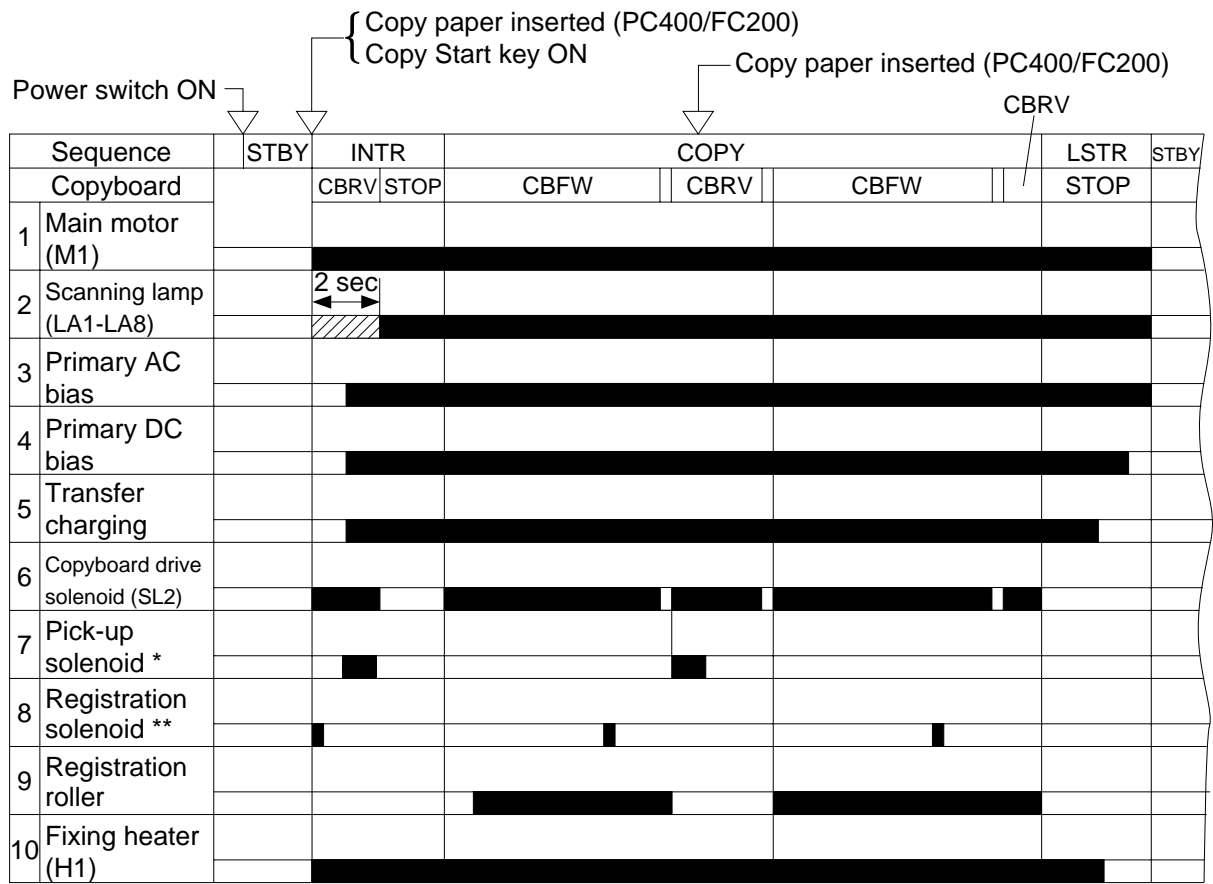

Figure 2-101B

C. Basic Sequence of Operations (A4, 2 copies)



*PC420/430/FC220

**PC400/FC200

Figure 2-101C

Period		Description	Remarks
STBY (Standby)	Between when the copier is switched ON and when the Copy Start key is pressed. Between when LSTR is over and when the Copy Start key is pressed.	Waits for a press on the Copy Start key.	
INTR (Initial Rotation)	For about 6 sec after STBY is over.	Executes pick-up. Removes residual charge from the photosensitive drum and stabilizes the drum sensitivity in preparation for copying operation.	The copyboard moves from the home position to the start position.
COPY	CBFW (Copyboard Forward)	While the copyboard is moving forward (about 10 sec).	The scanning lamp illuminates the document, and the reflected optical image is projected to the photosensitive drum through the lens array.
	CBRV (Copyboard Reverse)	While the copyboard is moving in reverse (about 4 sec).	Returns the copyboard to the start position in preparation for the next copy; if last copy, the copyboard is returned to the home position.
LSTR (Last Rotation)	After CBRV for the last copy is over until 3 sec after the copy paper has moved past the delivery sensor.	Discharges the last copy.	

Table 2-101C

D. Main Motor Control Circuit

1. Outline

Figure 2-101D shows the circuit that controls the main motor (M1), and the circuit has the following functions:

- a. turns the main motor ON and OFF.
- b. controls the main motor speed (constant)

The main motor (M1) is a DC motor and is equipped with a motor rotation sensor (Q901) to serve as a clock pulse generator. Clock pulses (MMCLK) corresponding to the revolution of the motor are generated while the motor is rotating. The speed control circuit controls the speed of the motor with reference to these clock pulses.

2. Operation

The drive circuit on the DC controller/DC power supply PCB causes the main motor drive command (MMD) to go '0' in response to instructions from the microprocessor, thereby causing the main motor to rotate at a specific speed.

3. Overcurrent Sensor

When the overcurrent sensor circuit detects an overload in the main motor (M1), the speed controller circuit exerts control so that the rotation of the motor is slowed down.

If the revolution of the main motor falls below a specific revolution, however, an error associated with 'E2' can occur.

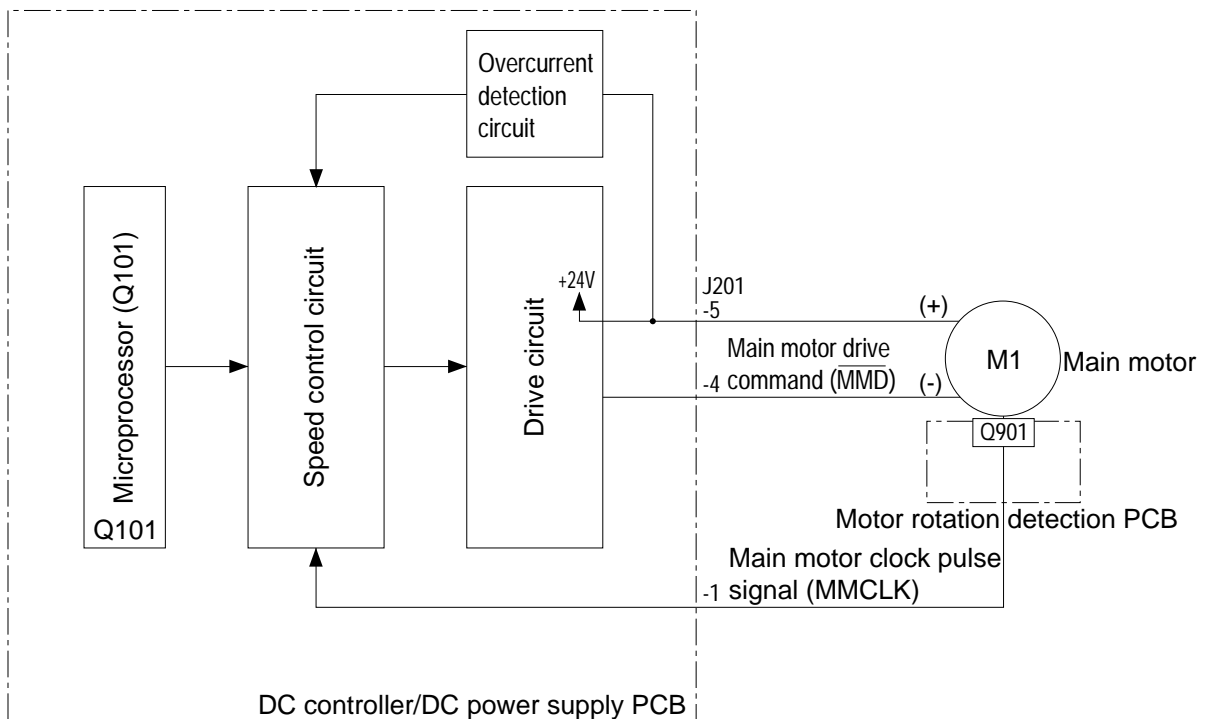

Figure 2-101D

E. Inputs to DC Controller

1. Inputs to DC Controller (1/2)

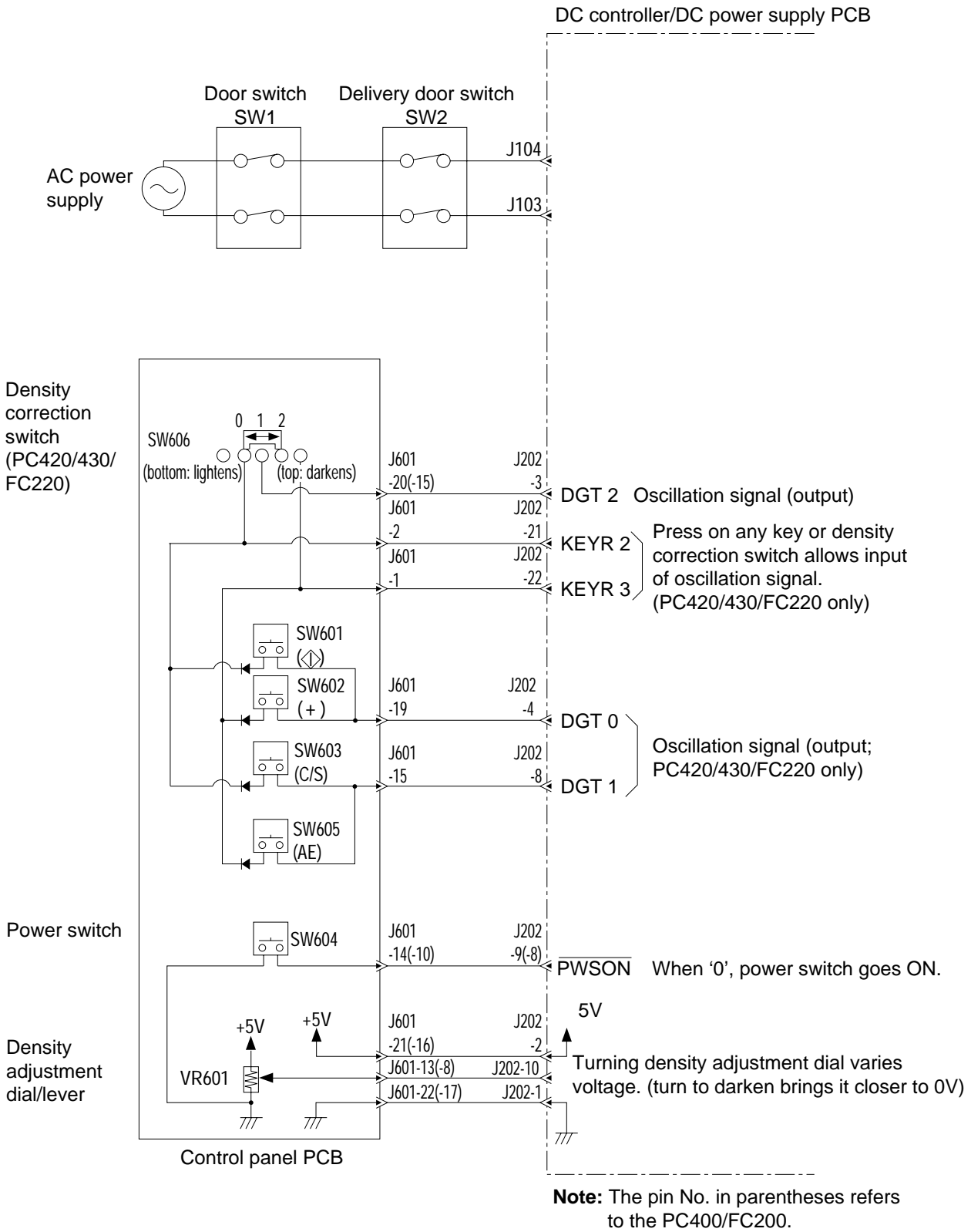
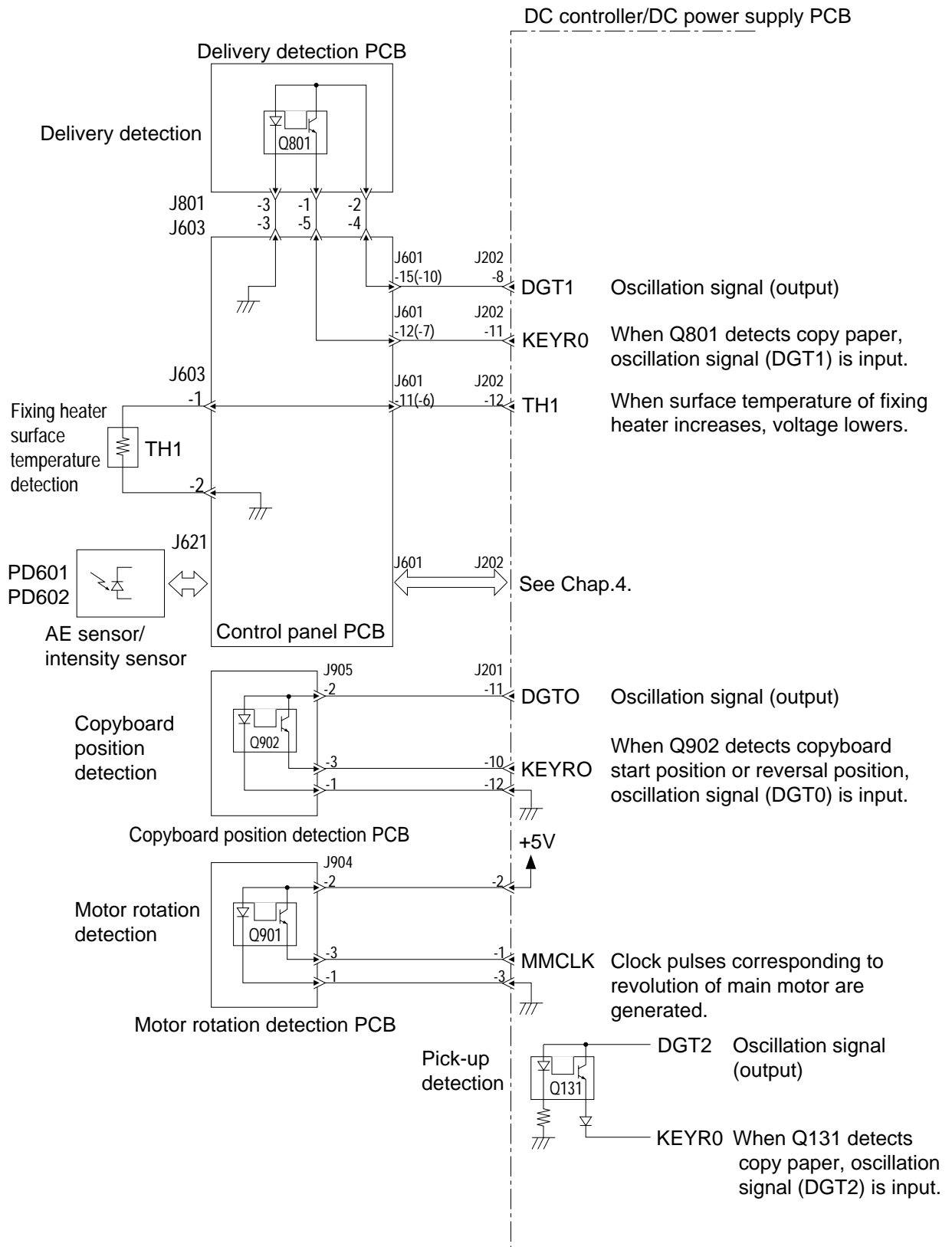

Figure 2-101E

2. Inputs to DC Controller (2/2)



Note: The pin No. in parentheses refers to the PC400/FC200.

Figure 2-102E

F. Outputs from DC Controller

1. Outputs from DC Controller (1/2)

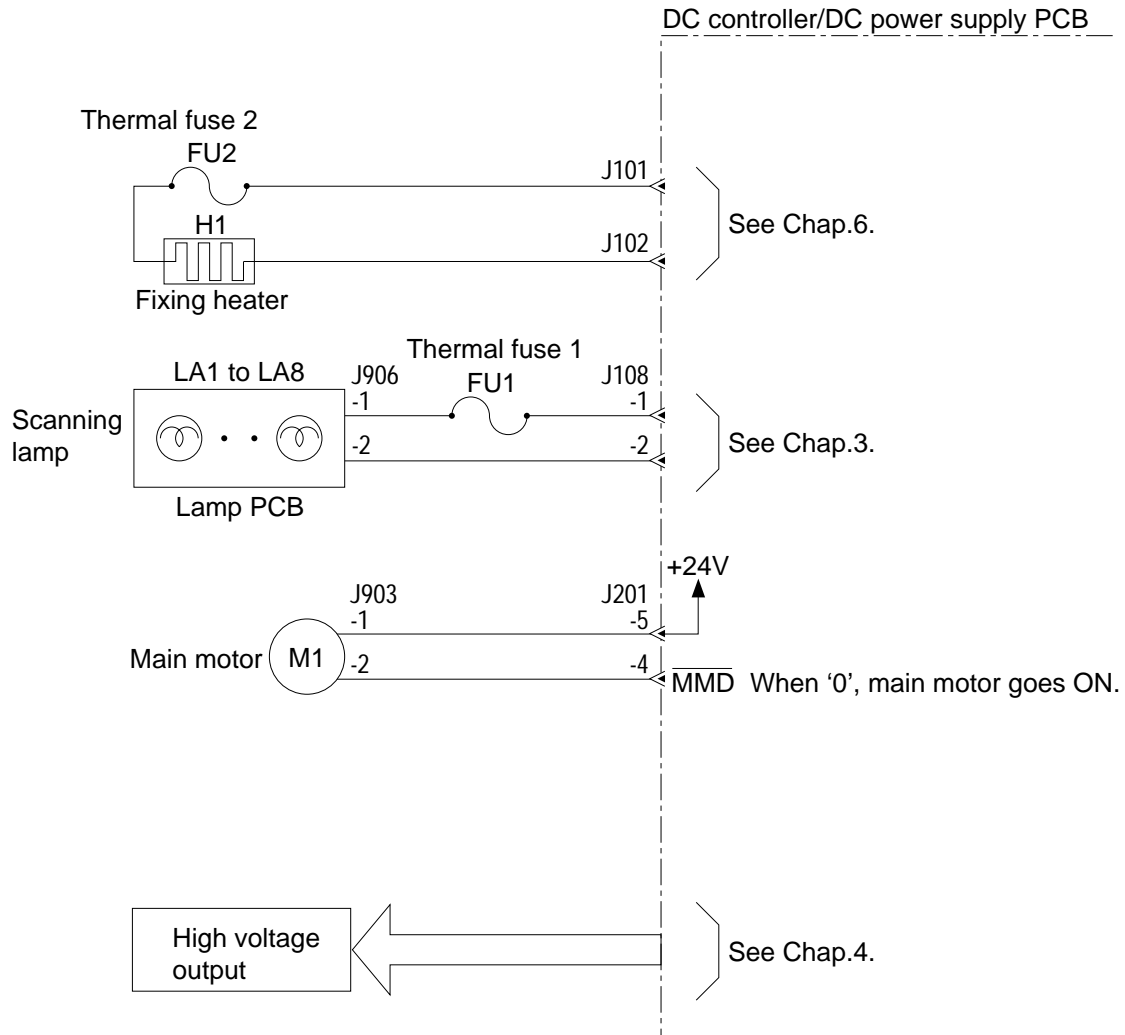

Figure 2-101F

2. Outputs from DC Controller (2/2)

a. PC420/430/FC220

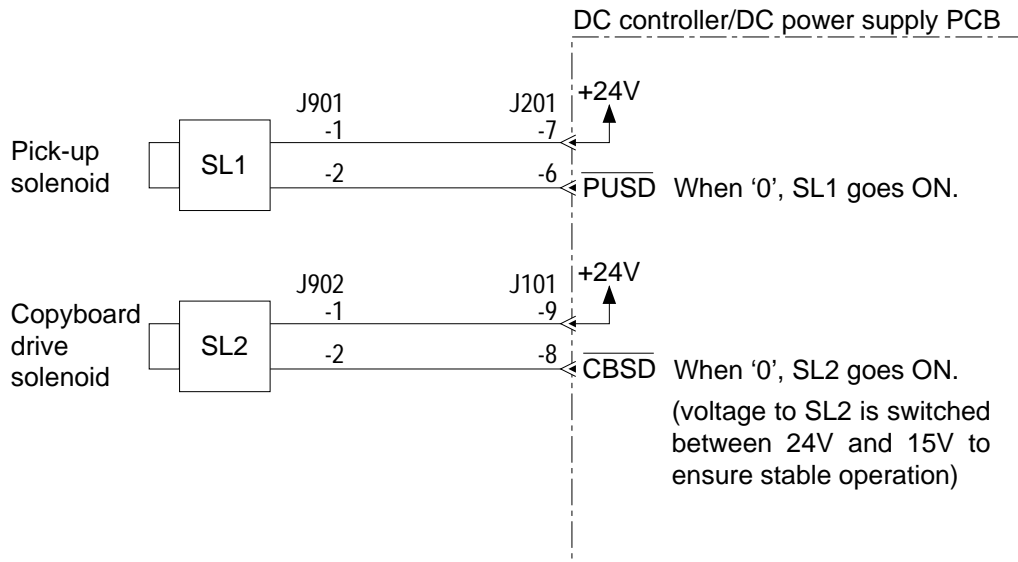

Figure 2-102F

b. PC400/FC200

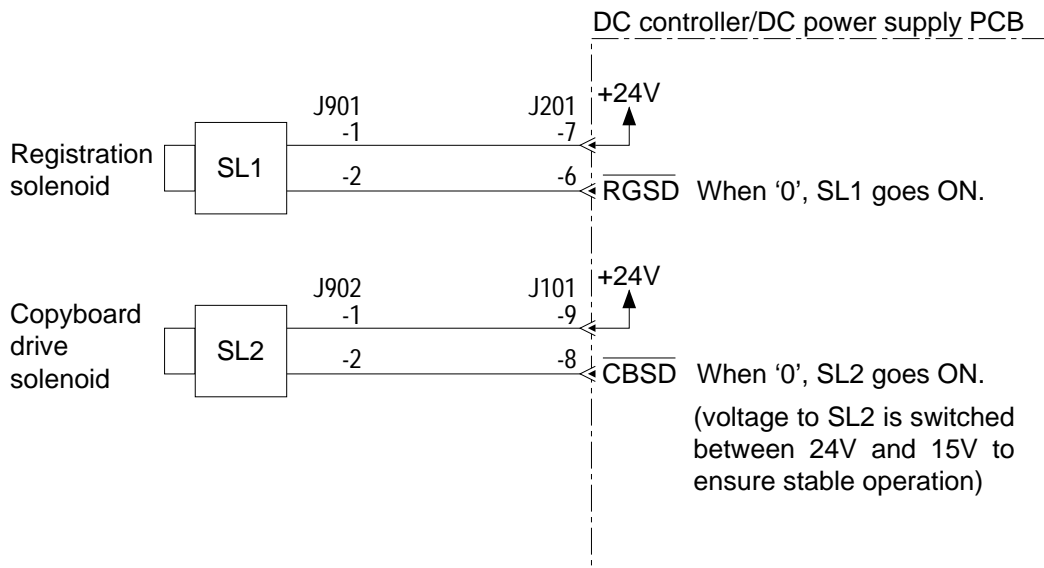

Figure 2-103F

CHAPTER 4

IMAGE FORMATION SYSTEM

This chapter outlines the machine's image formation system in relation to mechanisms and functions, relationship between electrical and mechanical systems, and the timing of operation of respective parts.

I. PROCESS DESCRIPTION.....4-1	F. Document Density Measurement (AE; PC420/430/FC220).....4-14
A. Outline4-1	II. CHARGING, DEVELOPING, AND CLEANING SYSTEMS4-17
B. Sequence of Image Formation Operations (A4, 2 copies)4-2	A. Cartridge4-17
C. Primary Charging Control Circuit4-3	III. MECHANICAL SYSTEM.....4-18
D. Controlling Developing Bias....4-6	A. Photosensitive Drum.....4-19
E. Transfer Charging Control Circuit4-10	B. Transfer Charging Roller.....4-20

Blank Page

I. PROCESS DESCRIPTION

A. Outline

The copier's image formation system has the following functions:

- Controls the scanning lamp.
- Controls the primary charging.
- Controls the transfer charging.
- Controls the developing bias.

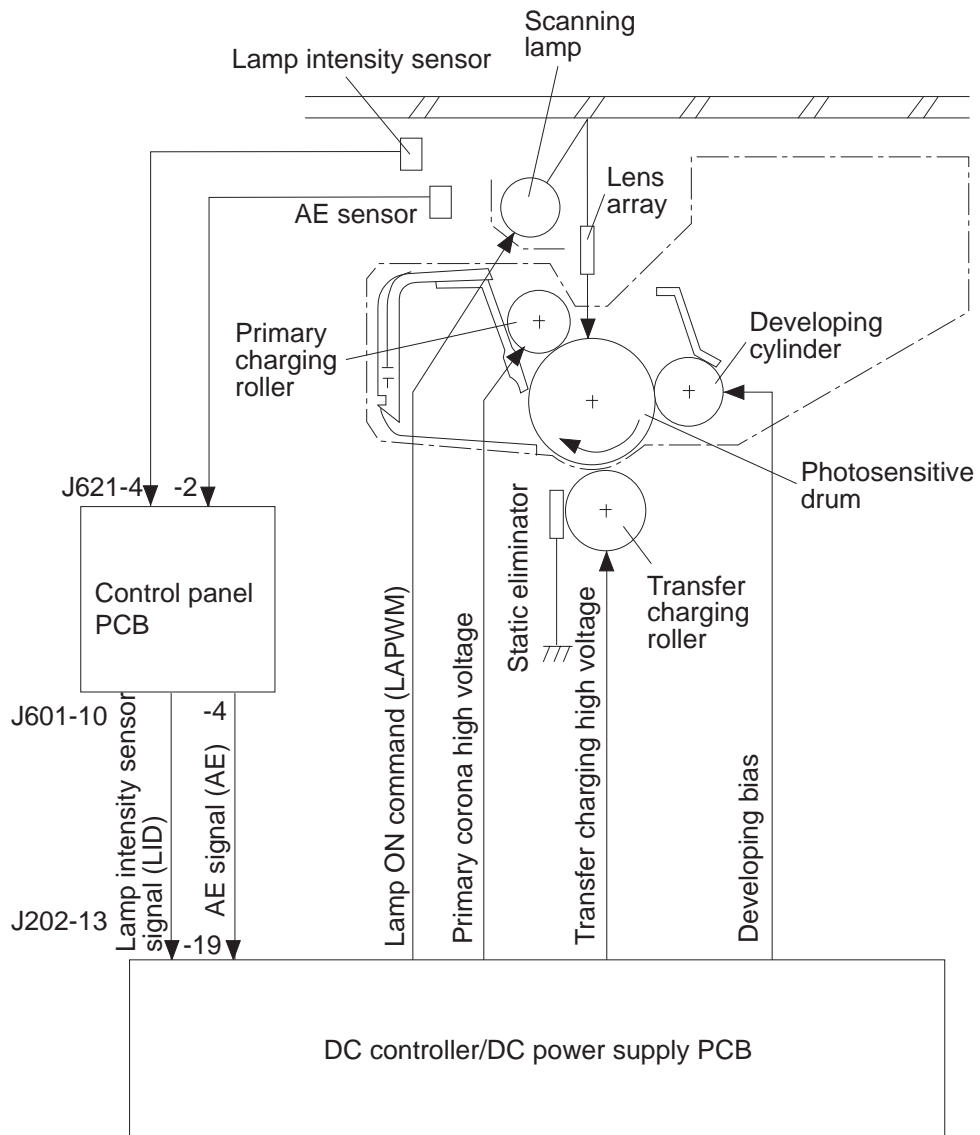

Note : The AE sensor is provided for the PC420/430/FC220 only.

Figure 4-101A

B. Sequence of Image Formation Operations (A4, 2 copies)

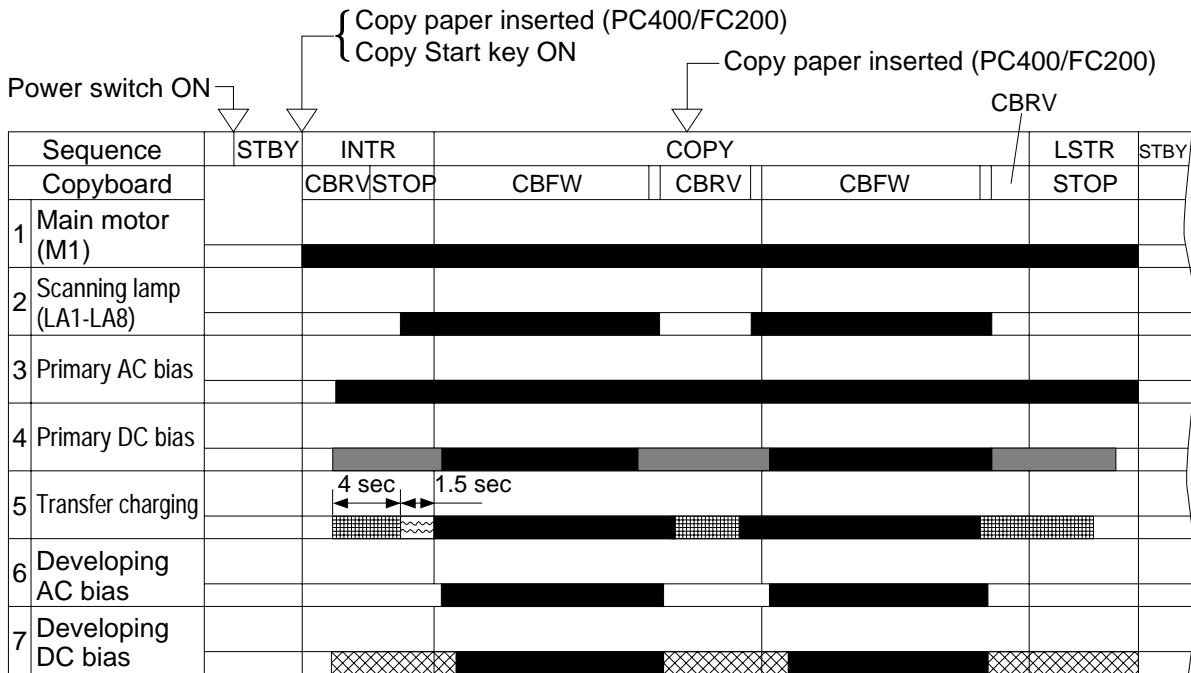

Scanning lamp **■** : ON

Primary DC bias **■** : -230V
■ : -625V

Developing DC bias **■** : -400V
■ : -120V to -560V
(variable according to density control dial/lever, AE)

Transfer charging **■** : Cleaning mode
■ : Measurement mode
■ : Transfer

Figure 4-401B

C. Primary Charging Control Circuit

1. Outline

Figure 4-101C shows the circuit that controls the primary charging, and the circuit has the following functions:

- Turns the DC bias ON and OFF.
- Turns the AC bias ON and OFF.
- Controls the DC bias voltage (constant).
- Controls the AC bias current (constant).

A DC bias (-625 V/-230 V) and an AC bias are applied to the primary charging roller to maintain the surface potential of the photosensitive drum uniform.

During document exposure (-625 V) and non-exposure periods (-230 V) DC bias is switched by the DC bias high output command (HVPHO).

The DC bias and AC bias are turned ON and OFF by the DC bias ON command (HVPDC) and AC bias ON command (HVPAC), respectively.

Reference:

Unless the document is being illuminated, the DC bias is switched to -230V to prevent adhesion of toner on the photosensitive drum.

2. Operations

a. HVPDC=1, HVPHO=1 (copying)

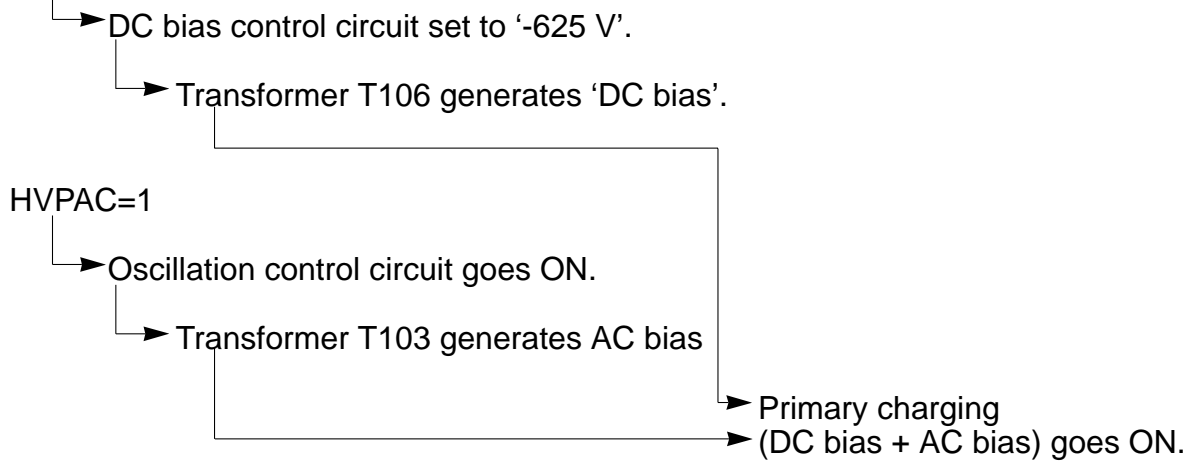

b. HVPDC=1, HVPHO=0 (document not exposed)

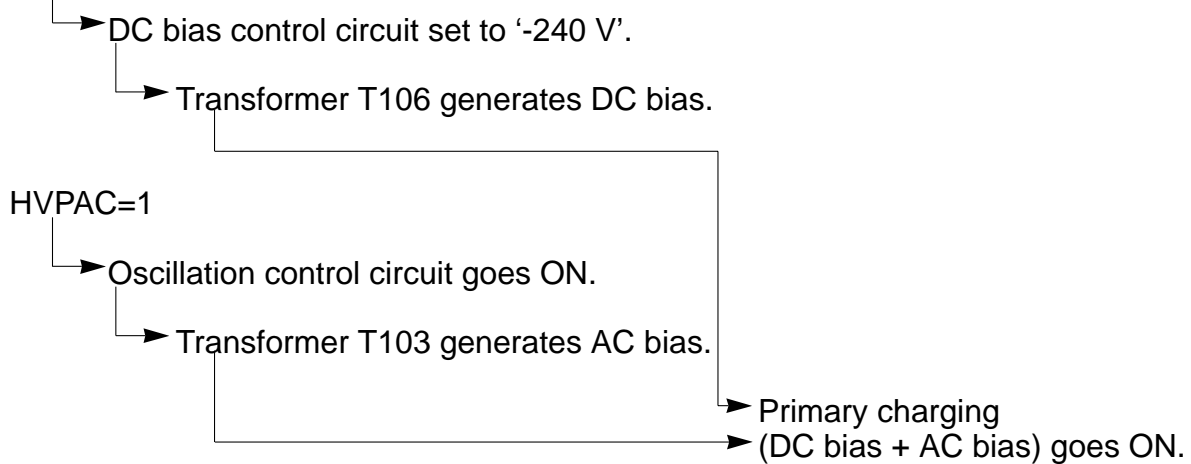

c. HVPDC=0, HVPHO=0 (standby)

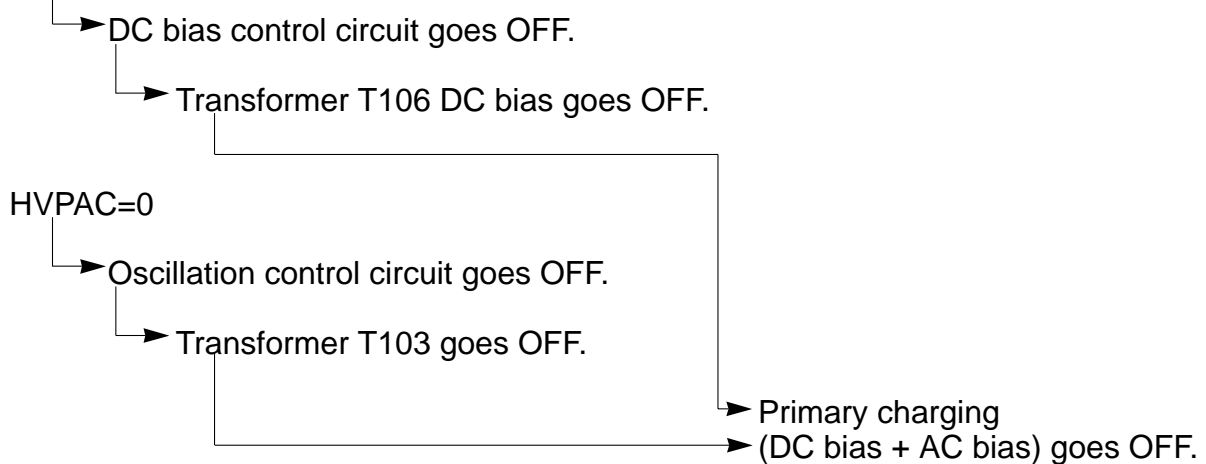

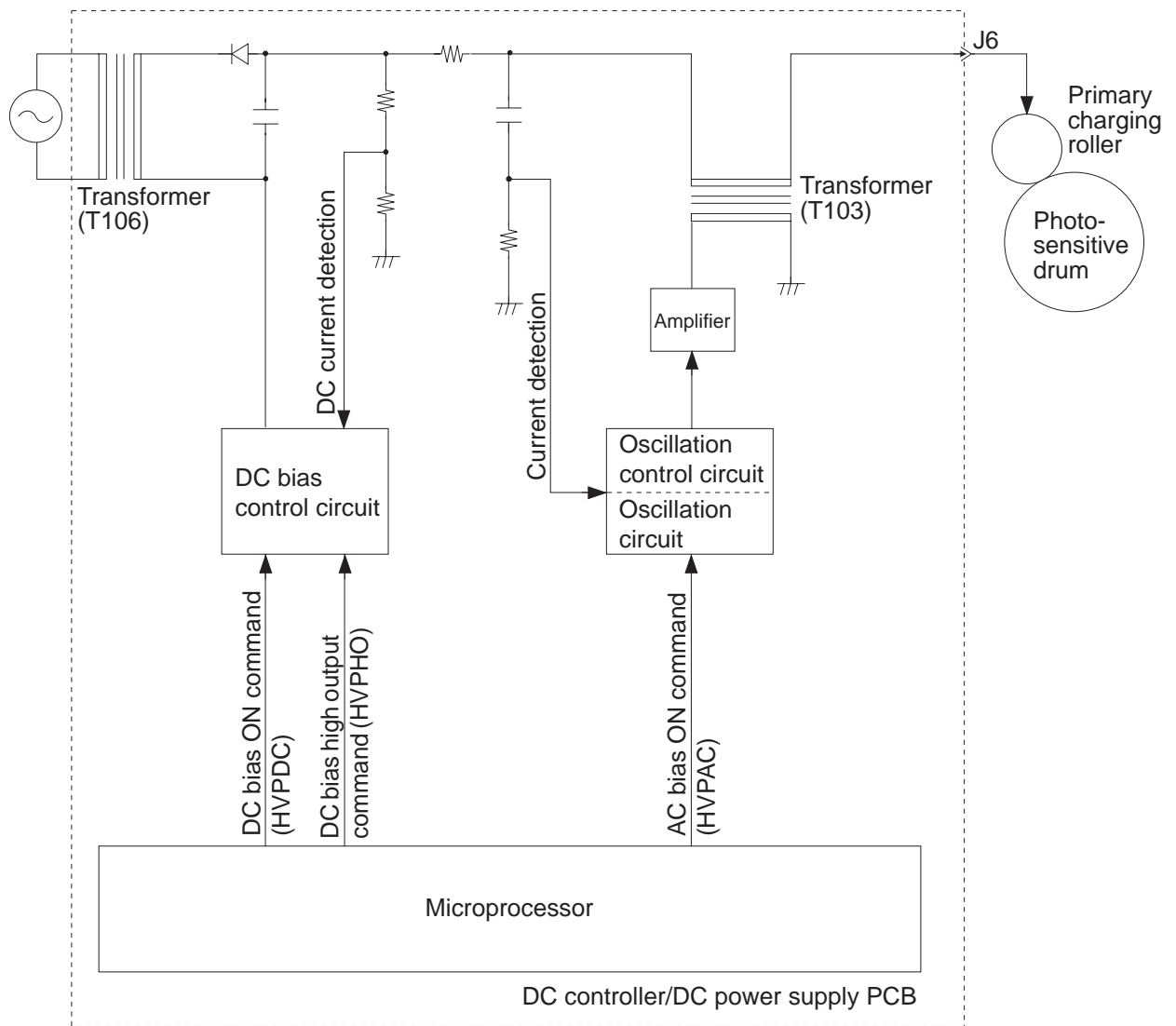

Figure 4-101C

D. Controlling Developing Bias

1. Outline

Both AC bias and DC bias are applied to the developing cylinder during copying operation.

When the photosensitive drum is rotating except during development, about -400 V is applied to the developing cylinder regardless of the settings made by the density control dial/lever, thereby preventing adhesion of excess toner on the surface of the photosensitive drum.

The copier controls the copy density by varying the voltage of the DC component of the developing bias (-120 to -560 V) based on the following:

- Setting made by the density control dial/lever (manual density control).
- Output of the AE sensor (automatic density control; PC420/430/FC220).
- Setting made by the density correction switch (SW606; PC420/430/FC220).

The density correction switch (SW606) on the control panel PCB allows three settings by the user. Advise the user to change the setting if the copies tend to be foggy because of shifts in the sensitivity of the photosensitive drum. SW606 is valid for manual density control as well.

Figure 4-101D,102D shows the changes in the DC component of the developing bias caused by the density control dial/lever in manual density control mode; Figure 4-103D, on the other hand, shows changes in the DC component of the developing bias caused by different document densities in automatic density adjustment mode (AE).

Note:

The copier does not change the developing bias between black toner and color toner. This is because the color toner used by the copier is a single-component agent, which allows the use of the same developing bias as for the black toner for development.

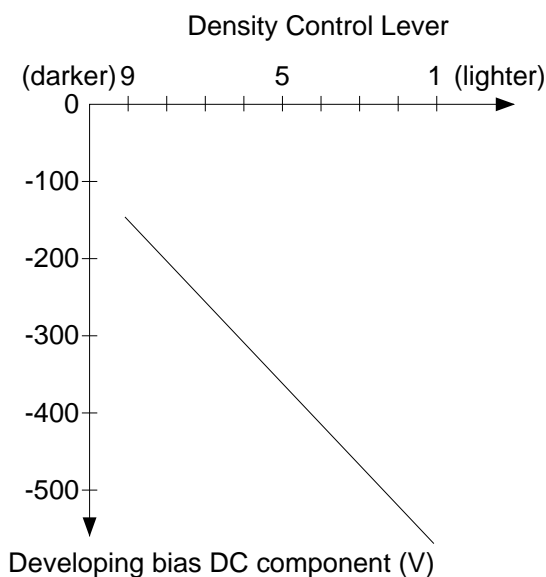

Figure 4-101D
Manual Density Control (PC400/FC200)

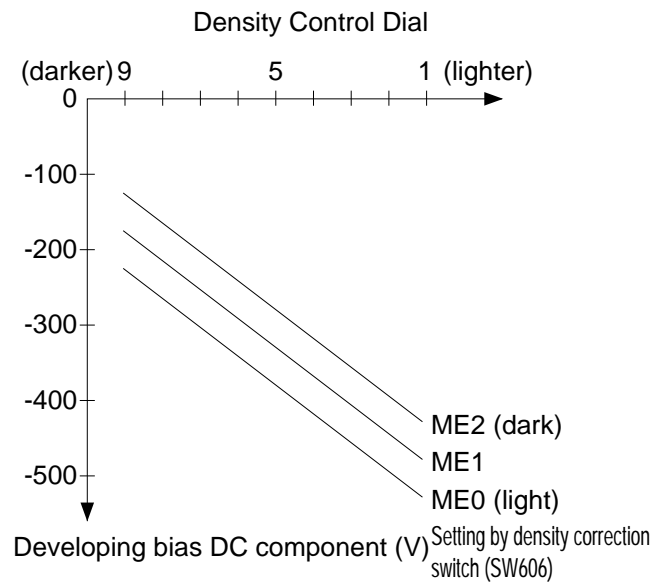

Figure 4-102D
Manual Density Control (PC420/430/FC220)

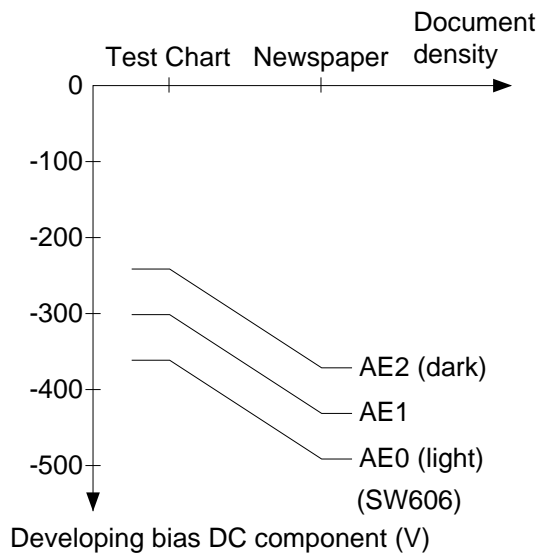

Figure 4-103D
Automatic Density Control (PC420/430/FC220)

2. Operations

Figure 4-104D shows the circuit that controls the developing bias, and the circuit has the following functions:

- Turns the developing bias AC component ON and OFF.
- Turns the developing bias DC component ON and OFF.
- Controls the voltage level of the DC bias according to the settings made by the copy density dial/lever.

a. Turning the Developing Bias AC Component ON and OFF

- ACBTP=0 (pulse output OFF)

└─▶ T104 goes OFF.

The above condition deprives the developing cylinder of the AC bias.

- ACBTP=1 (pulse output ON)

└─▶ T104 goes ON.

The above condition raises the AC bias output using the high-voltage transformer (T104) and sends it to the developing cylinder.

b. Turning the DC Bias ON and OFF and Controlling the Voltage Level

The DC bias is turned ON and OFF by the DC bias control command (DCBPWM).

The microprocessor checks the DC voltage when the DC bias is ON so as to keep it to the specified voltage.

a) DCBPWM=0 (DC bias OFF)

└─▶ Q146 goes ON.

└─▶ DC bias goes OFF.

b) DCBPWM=1 (DC bias ON)

└─▶ Q146 goes OFF.

└─▶ DC bias goes ON.

The voltage level of the DC bias is controlled by varying the pulse width of the DC bias control command (DCBPWM).

While the photosensitive drum is rotating except during development, about -400 V is applied to the developing cylinder.

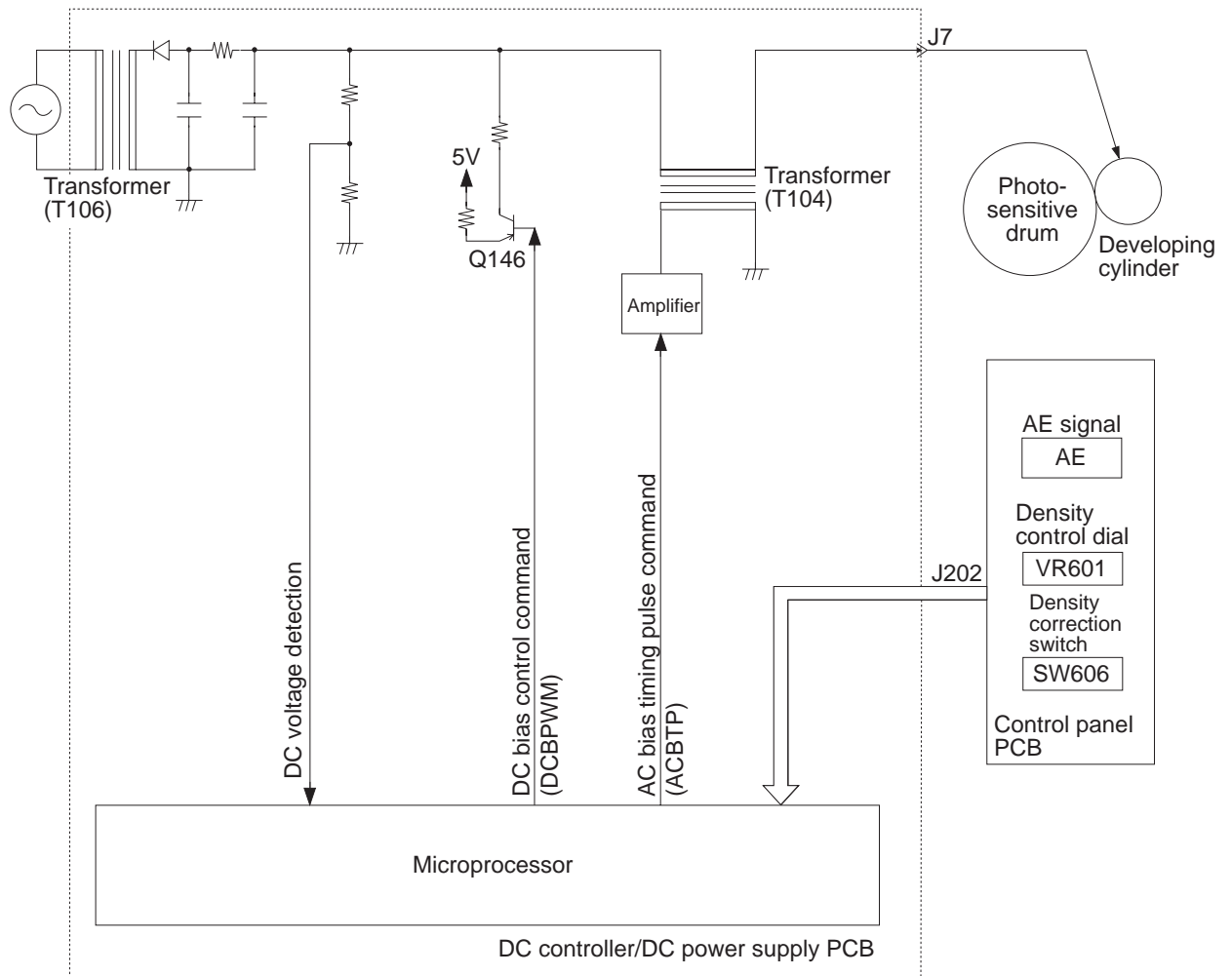

Figure 4-104D

E. Transfer Charging Control Circuit

1. Outline

Figure 4-101E shows the circuit that controls transfer charging, and the circuit has the following functions:

- Controls the constant current in measurement mode.
- Controls the constant voltage of the DC bias.
- Switches the polarities of the DC bias (cleaning mode).

The internal resistance of the transfer corona roller tends to vary from one roller to another or because of changes in the environment.

The copier sends constant current to the transfer charging roller so that the microprocessor can check the changes in terms of voltage (measurement mode).

Based on the measured voltage, the microprocessor corrects the DC bias.

Further, the copier is equipped with a cleaning mechanism (cleaning mode) that prevents adhesion of toner to the transfer charging roller.

In cleaning mode while the drum is rotating, except during transfer, a DC bias is applied to the transfer charging roller with a reversed polarity, thereby returning the toner to the photosensitive drum.

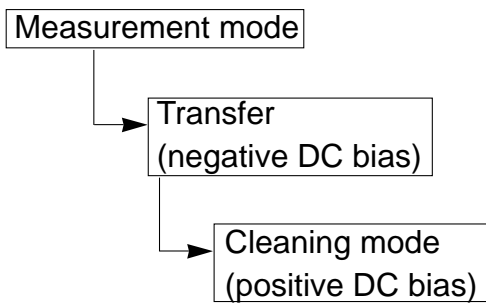

2. Operations

a. Operations in Measurement Mode

HVTDC=1, DCTPWM=0

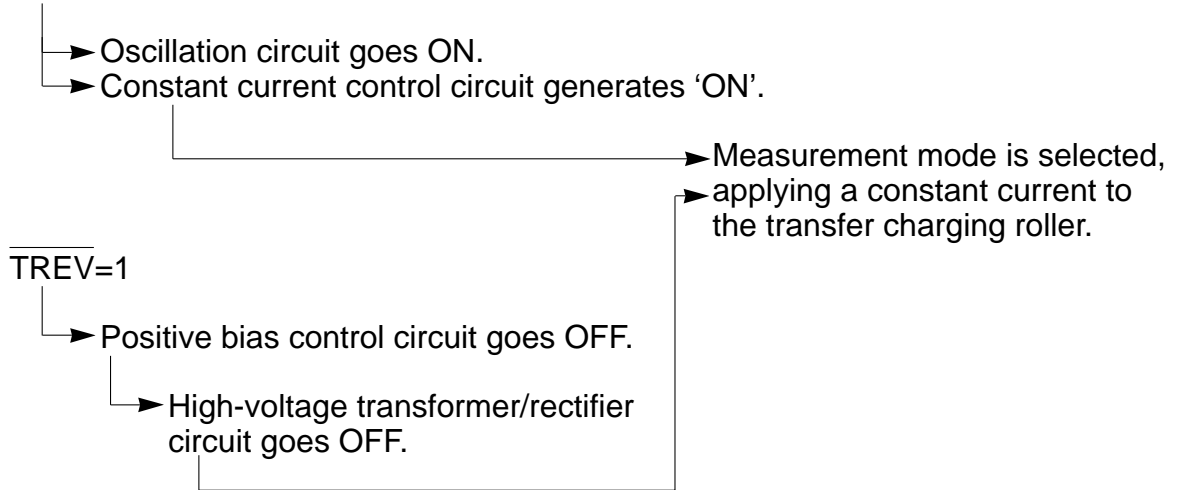

In measurement mode, the current is monitored by the current sensor circuit so that the constant current control circuit can control it to a constant current.

Further, the microprocessor monitors the internal resistance of the transfer charging roller in terms of voltage using the auxiliary winding of the transformer (T107).

b. Operations during Copying

HVTDC=1, DCTPWM=1

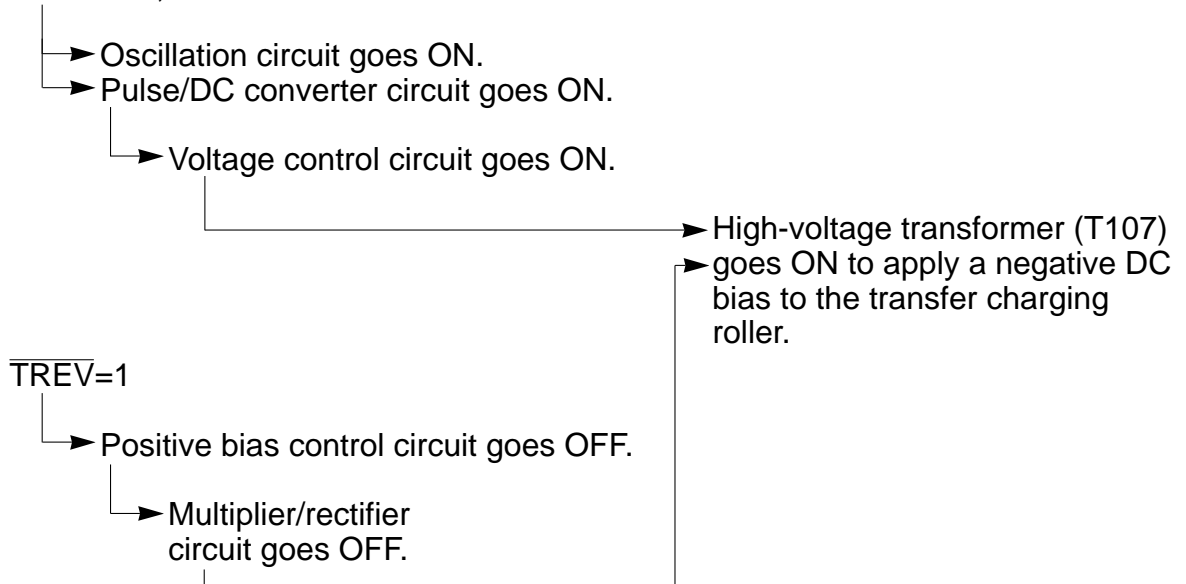

The microprocessor varies the pulse width of the transfer DC bias control command (DCTPWM) according to the internal resistance of the transfer charging roller affected by the surrounding environment, thereby controlling the negative DC bias.

If an overcurrent occurs in the output side of the transformer (T107) because of changes in the environment, the current limiter circuit exerts control so that no current larger than the specified value will flow.

c. Operations in Cleaning Mode

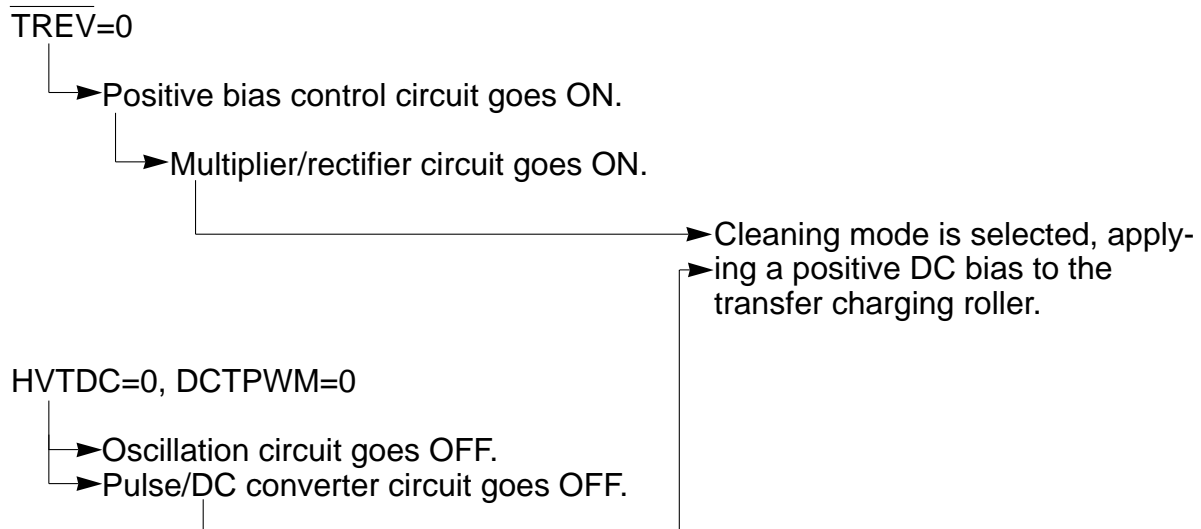

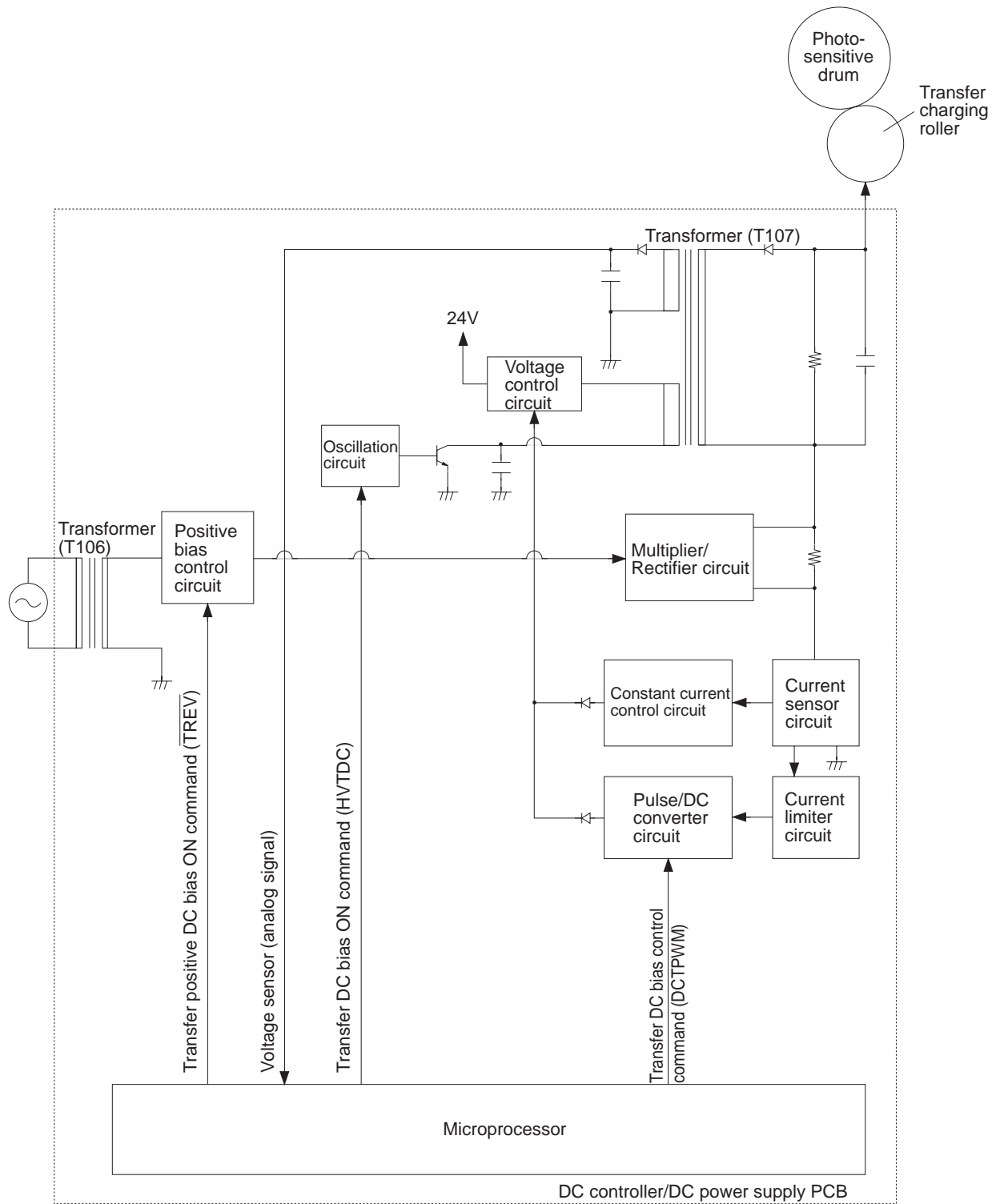

Figure 4-101E

F. Document Density Measurement (AE; PC420/430/FC220)

1. Outline

The copier is equipped with an automatic density control (AE) mechanism that controls the DC component of the developing bias. The copier's AE mechanism does not execute an AE scan, but instead measures the document density during image exposure.

2. Operations

Document measurement is started while the copyboard is moving forward; i.e., when the leading edge of the document begins to be exposed (copyboard position sensor Q902 goes OFF).

At the time, the photodiode (PD602) checks the reflected light.

The output of the photodiode (PD602) is amplified, and sent to the microprocessor as AE signals.

<AE Measurement Timing Chart>

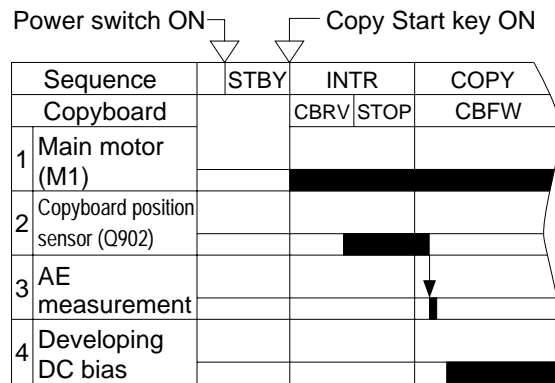

Figure 4-101F

The microprocessor takes measurements of the AE signals four times every 1.5 mm, and generates the developing DC bias control command (DCBPWM) to suit the average document density. See Figure 4-102F for the points at which the document density is measured in relation to the copyboard glass.

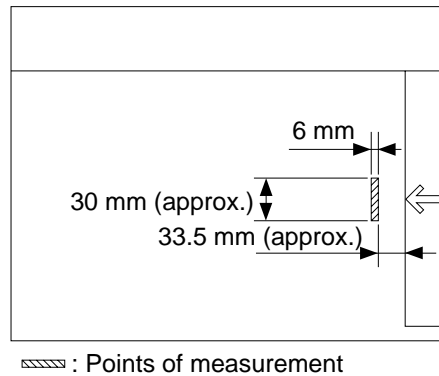

Figure 4-102F

3. Adjusting the AE Mechanism (VR602, VR603)

You must adjust the AE mechanism if you have replaced the scanning lamp unit, control panel PCB, or intensity/AE sensor; see p.10-8.

Note:

Adjust the AE mechanism only after adjusting the intensity of the scanning lamp.

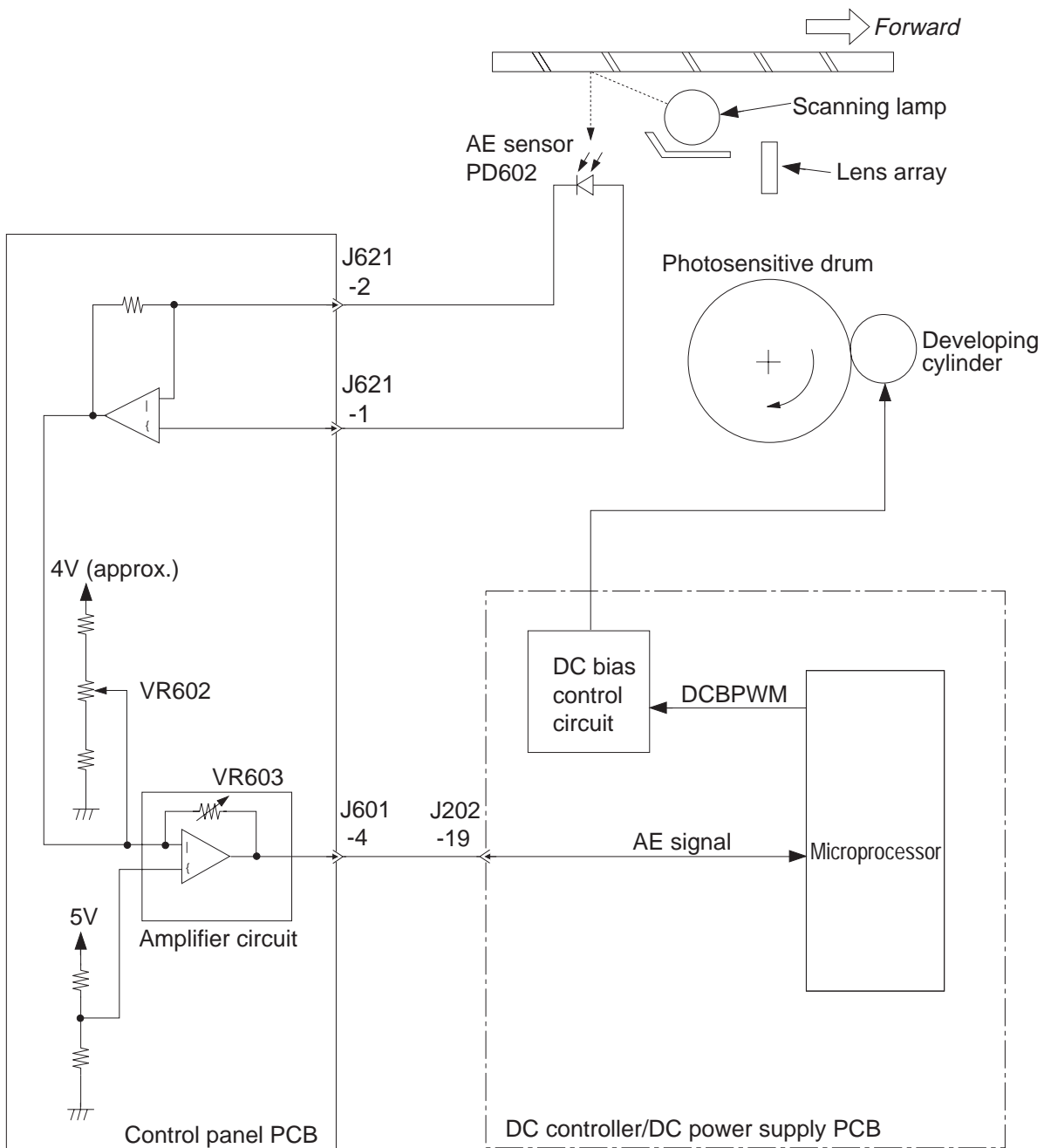

Figure 4-103F

II. CHARGING, DEVELOPING, AND CLEANING SYSTEMS

A. Cartridge

1. Outline

The copier is a cartridge type, in that its photosensitive drum, primary charging roller, developing assembly, and cleaner are designed as a single entity.

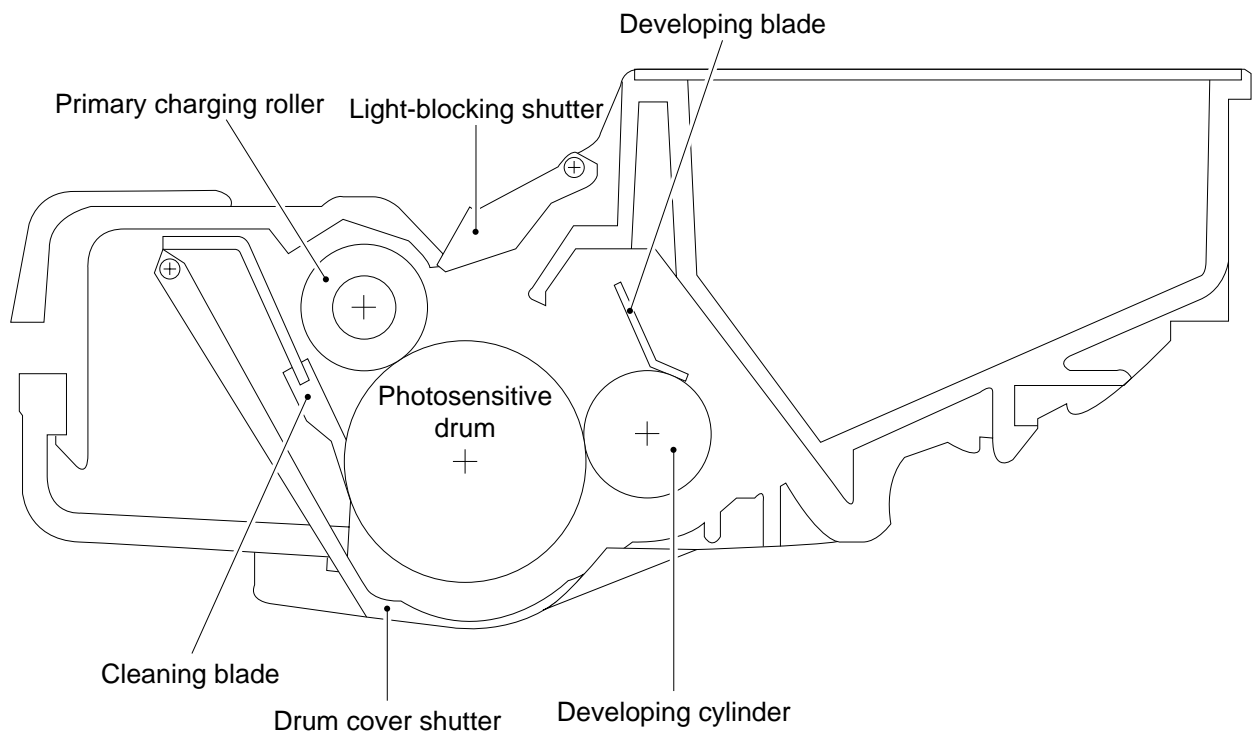

Figure 4-201A

a. Drum Cover Shutter

The photosensitive drum is susceptible to light; if exposed to strong light, it will develop residual memory, causing white spots or black lines on the copies. To avoid such problems, you must not open the drum cover shutter unless it is absolutely necessary. The drum cover shutter is designed to open when the cartridge is inserted into the copier and the copier's top unit is closed.

b. Light-Blocking Shutter

The absence of a cartridge inside the copier allows light to enter the inside of the copier from the opening created for exposure. The light-blocking shutter is provided to protect the photosensitive drum against intrusion of such light.

III.MECHANICAL SYSTEM

Here, the copier is discussed in terms of its mechanical characteristics and operation and how to disassemble and assemble it.

Be sure to observe the following for disassembly/assembly work:

1. ▲ Disconnect the power cord for safety before disassembly or reassembly work.
2. Unless otherwise noted, reassembly is the reverse of disassembly.
3. Group the screws by type (length and diameter) and location.
4. One of the mounting screws used on the rear cover is provided with a washer to protect against static electricity. Be sure to keep the washer with the screw when mounting the cover.
5. The fixing screw for the grounding wire and varistors is fitted with a washer to ensure electric continuity; be sure to use the washer for reassembly.
6. If possible, avoid operating the machine with any of its parts removed.

A. Photosensitive Drum

1. Cleaning the Drum

Caution:

As a rule, do not touch or clean the photosensitive drum.

- 1) Open the top cover, and take out the cartridge.
- 2) Put the cartridge upside down, and open the drum shutter.
- 3) Clean the surface of the drum using a flannel cloth coated with toner.

Caution:

1. You must rotate the drum in the direction it rotates for making copies; otherwise, the leaf spring used to apply developing biases to the developing cylinder may cause faulty contact.
2. Use a flannel cloth; do not use paper, lint-free or otherwise.
3. Work quickly to protect the drum from light.

Reference:

The drum would recover to more or less its normal condition if left alone for five minutes in a dark place after exposure to an intensity of 1500 lux (about 5 minutes under general lighting). However, you must try to avoid any exposure at all cost. (The rays of the sun have intensities ranging between about 10000 and 30000 lux.)

B. Transfer Charging Roller

1. Cleaning the Transfer Charging Roller

- 1) Open the top cover, and take out the cartridge.
- 2) Wipe off the dirt from the transfer charging roller lightly using lint-free paper.

Caution:

1. Do not use water or solvent.
2. Do not touch the roller; make sure the roller is free of solvent or oil.

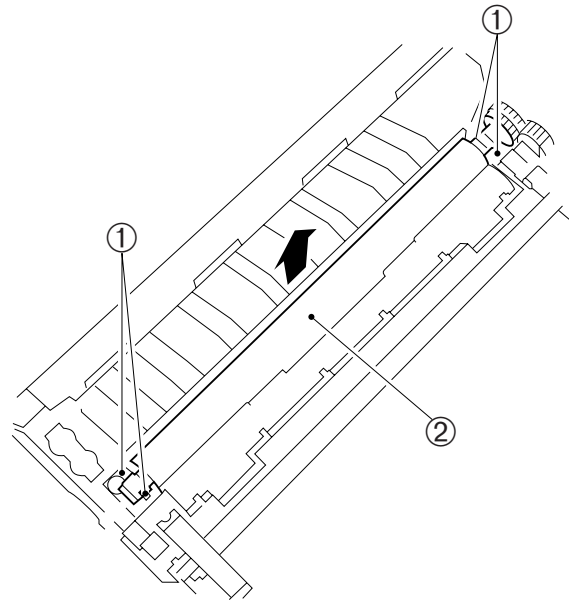

Figure 4-301B

2. Detaching the Transfer Charging Roller

- 1) Open the top cover, and take out the cartridge.
- 2) Free the tabs ① of the base plate, and take out the transfer charging roller ② by pulling it up together with its bushings; at this time, remove the spring as well.

Caution:

Make sure that the spring is fitted over the boss in the center of the hook when attaching the transfer charging roller; see Figure 4-302B.

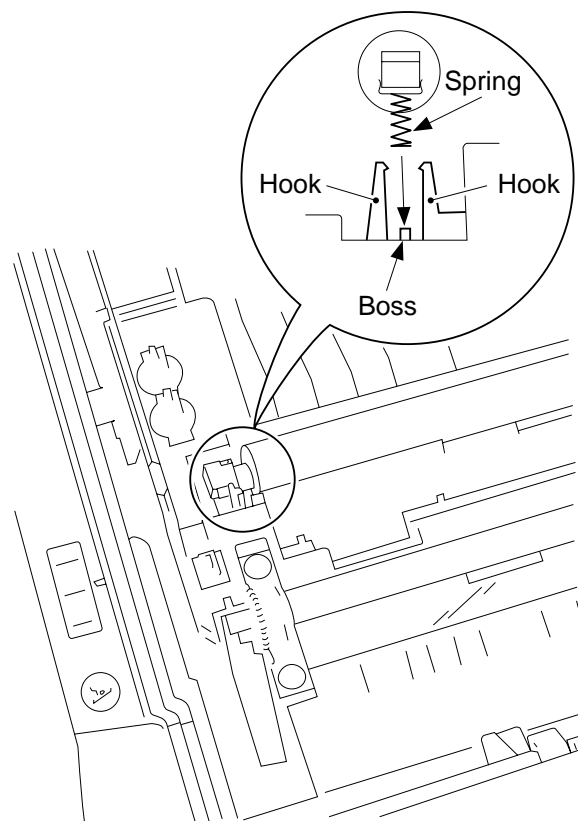

Figure 4-302B

CHAPTER 5

PICK-UP/FEEDING SYSTEM

This chapter outlines the machine's pick-up/feeding system in relation to mechanisms and functions, relationship between electrical and mechanical systems, and the timing of operation of respective parts.

I.	OUTLINE	5-1		
II.	CONTROLLING THE PICK-UP ROLLER.....	5-2		
	A. PC420/430/FC220	5-2		
	B. PC400/FC200	5-3		
III.	CONTROLLING THE REGISTRATION ROLLER	5-4		
	A. Outline	5-4		
	B. Pick-Up/Feeding Timing Chart (A4, 2 copies).....	5-5		
IV.	CHECKING FOR JAMS.....	5-6		
	A. Delivery Delay Jam.....	5-6		
	B. Delivery Stationary Jam.....	5-7		
			C. Pick-Up Delay Jam (PC420/430/FC220).....	5-8
			D. Pick-Up Stationary Jam	5-9
			E. Paper is present at the pick-up or delivery sensor at time of power- on or when the Copy Start key is pressed.	5-9
			V. MECHANICAL SYSTEM.....	5-10
			A. Pick-Up Roller Assembly.....	5-11
			B. Registration Roller Assembly	5-14
			C. Removing the Separation Pad	5-15

Blank Page

I. OUTLINE

The pick-up roller starts to rotate when the Copy Start key is pressed in the case of the PC420/430/FC220 and when paper is inserted, i.e., in response to the activation of the pick-up sensor (Q131), in the case of the PC400/FC200.

The copy paper is controlled by the registration roller so that its leading edge matches that of the image on the photosensitive drum; the paper is then moved to the transfer, separation, and fixing assemblies before it reaches the copy tray.

The delivery of copy paper is monitored by the delivery sensor (Q801); if copy paper fails to reach or move past the sensor, the copier identifies the condition as a jam and flashes 'Jam' on the control panel.

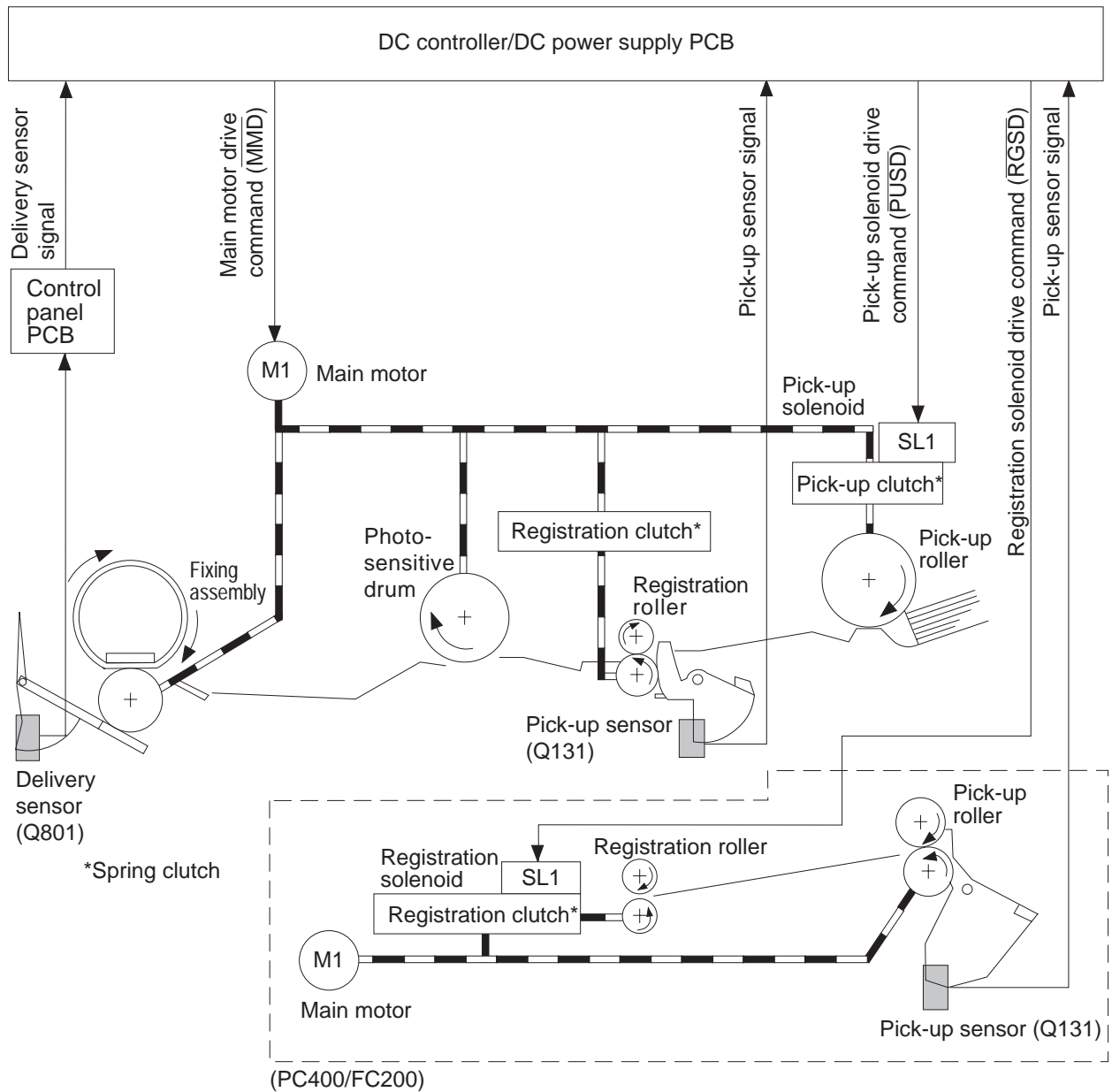

Figure 5-101

II. CONTROLLING THE PICK-UP ROLLER

A. PC420/430/FC220

The pick-up roller is controlled by a spring clutch, control ring, and pick-up solenoid (SL1).

When the pick-up solenoid goes ON, the claw moves away from the control ring, allowing the drive from the main motor (M1) to be transmitted, causing the pick-up roller to make a single rotation.

At the time, copy paper is picked up and butted against the registration roller, forming an arch.

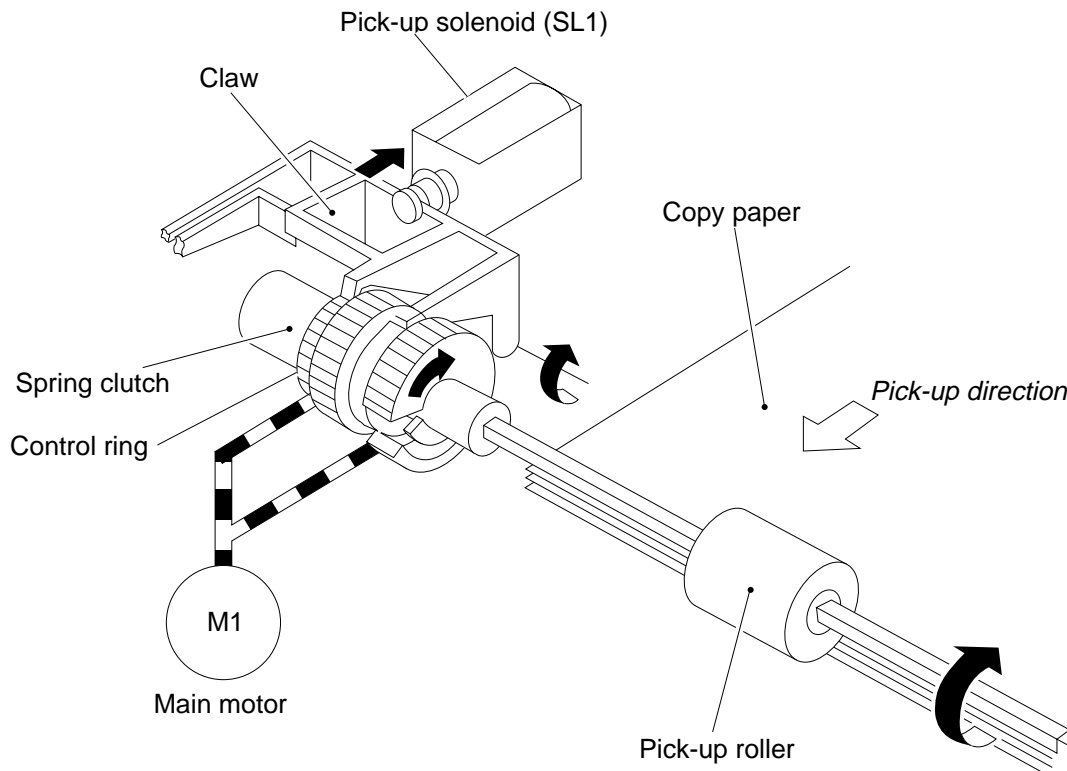

Figure 5-201A

B. PC400/FC200

When the pick-up sensor (Q131) detects copy paper, the main motor (M1) goes ON, causing the pick-up roller to rotate by its drive.

The pick-up roller keeps rotating as long as the main motor remains ON.

The condition causes the copy paper to butt against the registration roller.

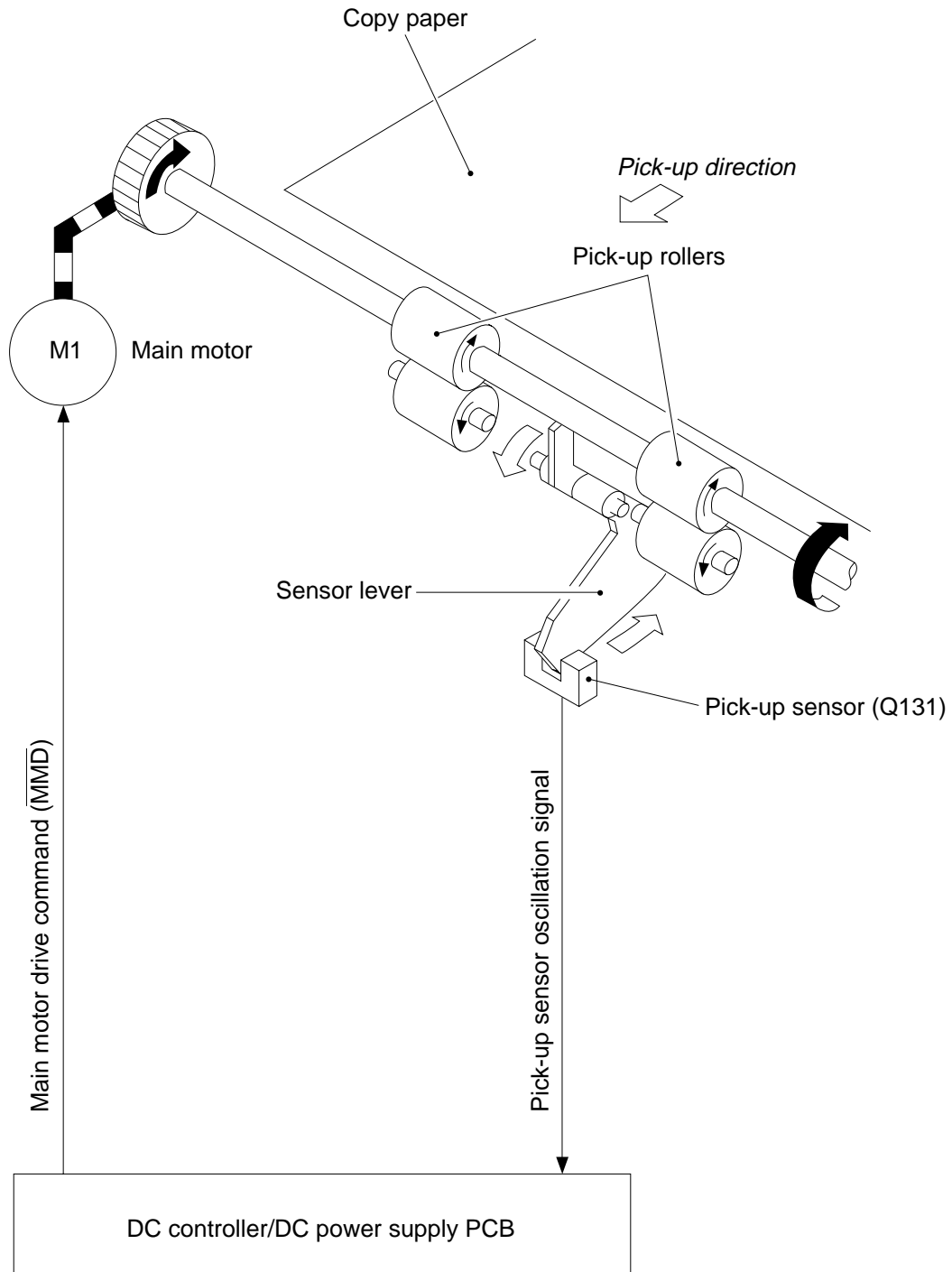

Figure 5-201B

III. CONTROLLING THE REGISTRATION ROLLER

A. Outline

The registration roller rotates when the registration cam found under the copyboard glass pushes the lever* while the copyboard is moving forward; see Table 3-2 and Figure 3-28.

* Frees the claw that holds the control ring.

The registration roller stops when the pick-up solenoid (PC420/430/FC220) or the registration solenoid (PC400/FC200) goes ON to set the claw to the control ring.

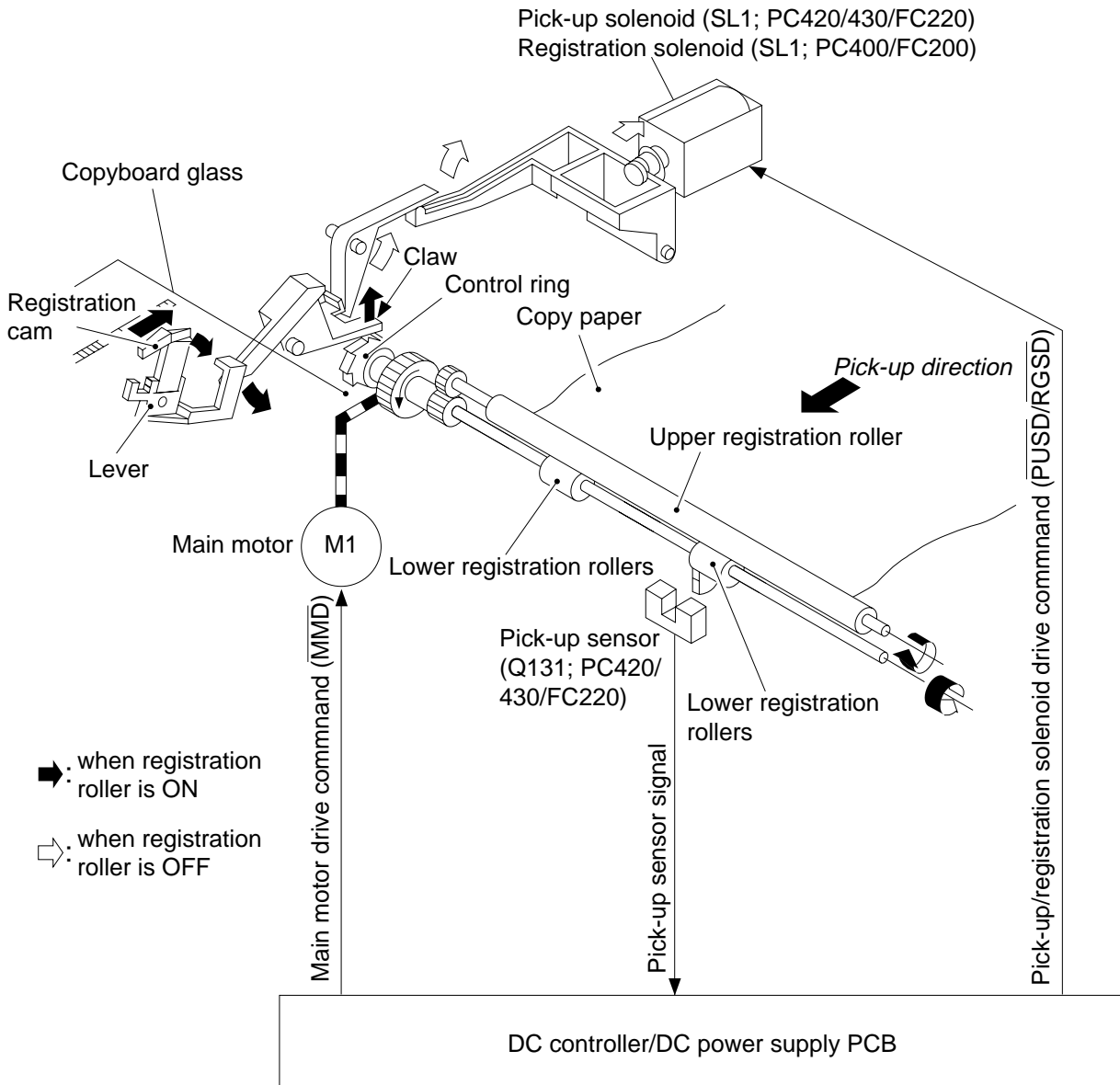

Figure 5-301A

B. Pick-Up/Feeding Timing Chart (A4, 2 copies)

a. PC420/430/FC220

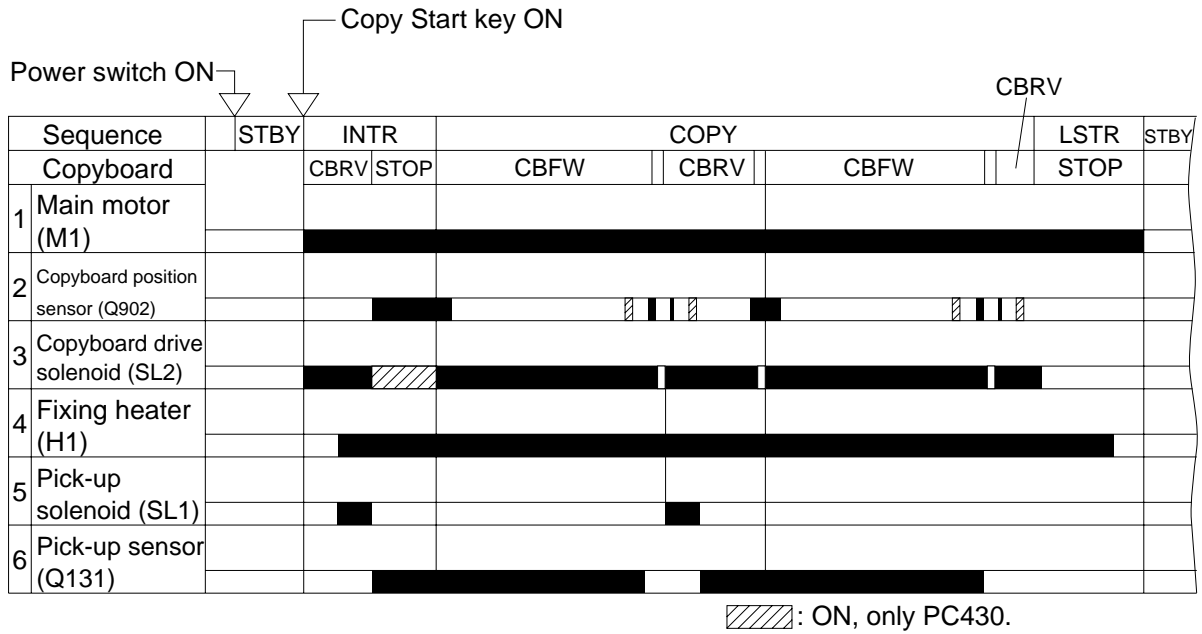

Figure 5-301B

b. PC400/FC200

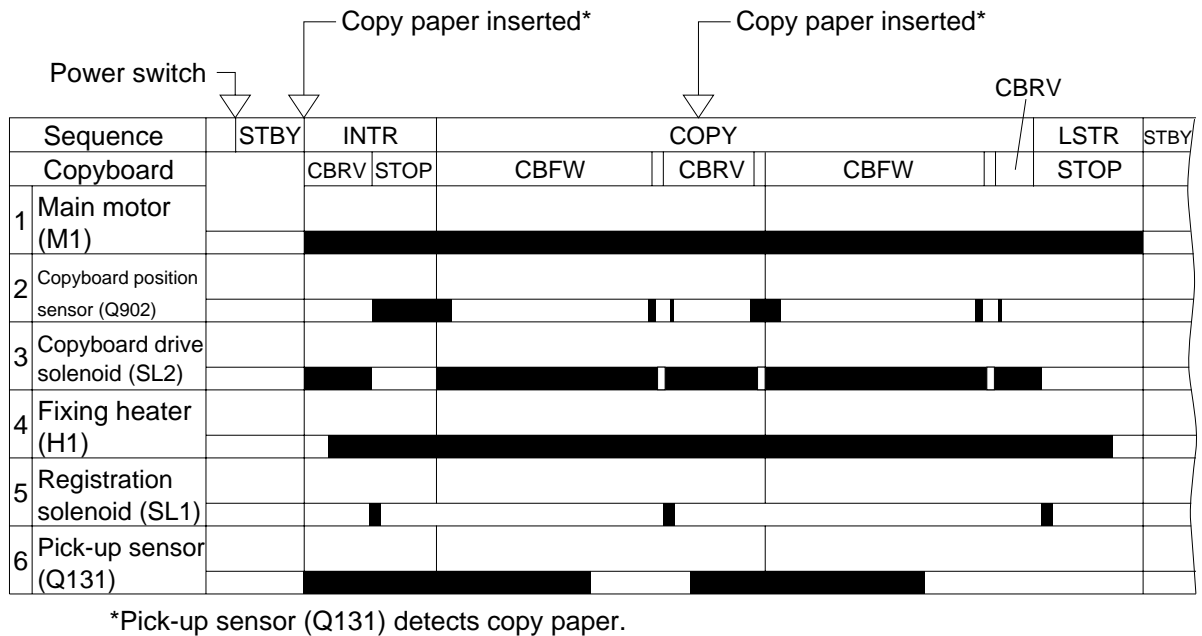

Figure 5-302B

IV. CHECKING FOR JAMS

The copier has a pick-up sensor (Q131) and a delivery sensor (Q801) to check if the paper is moving properly inside it.

Jams are identified by the presence of paper in the pick-up or delivery assembly at such times as preprogrammed in the microprocessor.

When the microprocessor identifies a jam, it immediately causes the main motor to go OFF and indicates the presence of a jam.

The microprocessor identifies the following conditions as jams.

A. Delivery Delay Jam

The copy paper does not reach the delivery sensor within a specific period of time.

1. PC420/430/FC220

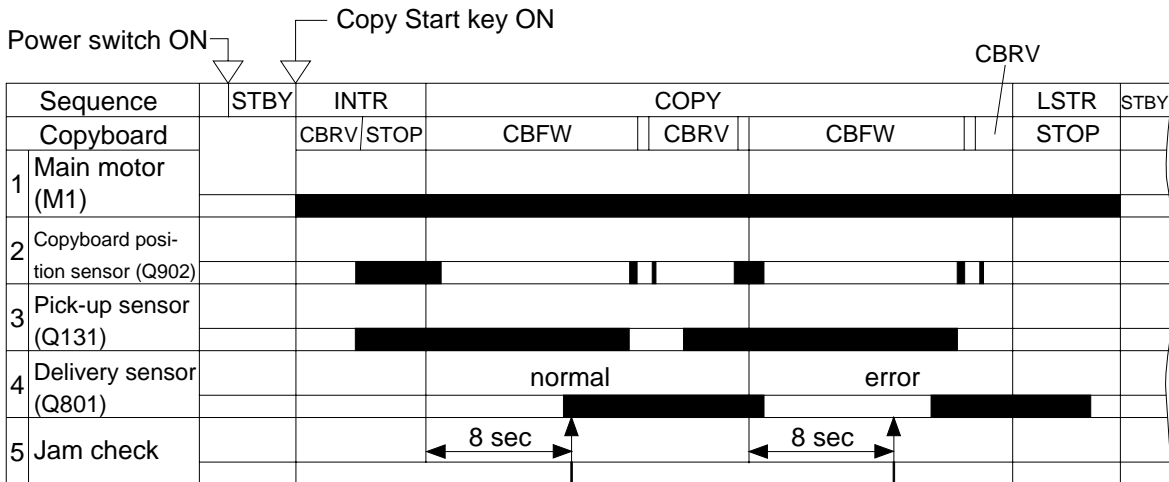

Figure 5-401A (A4)

2. PC400/FC200

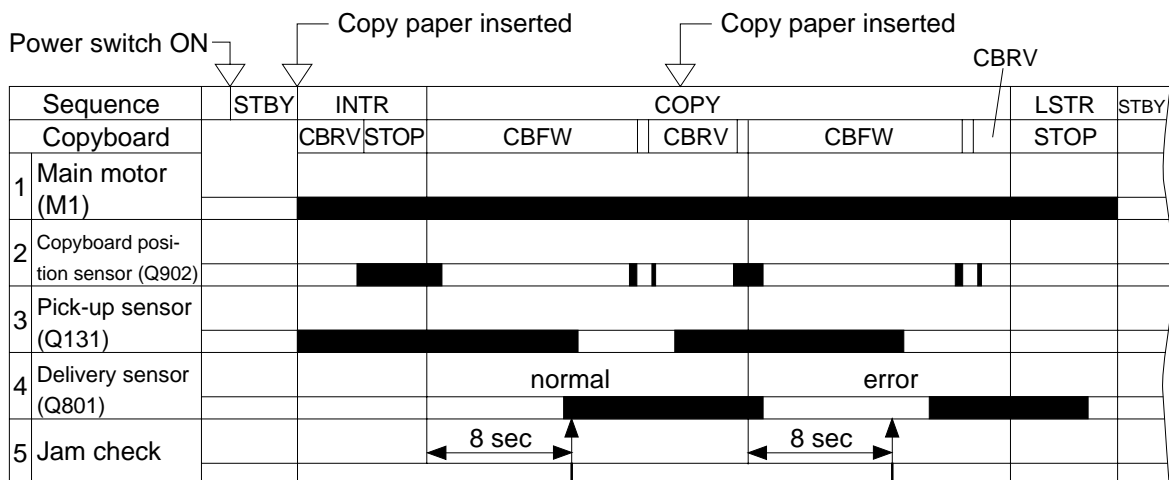

Figure 5-402A (A4)

B. Delivery Stationary Jam

The copy paper does not move past the delivery sensor within a specific period of time.

1. PC420/430/FC220

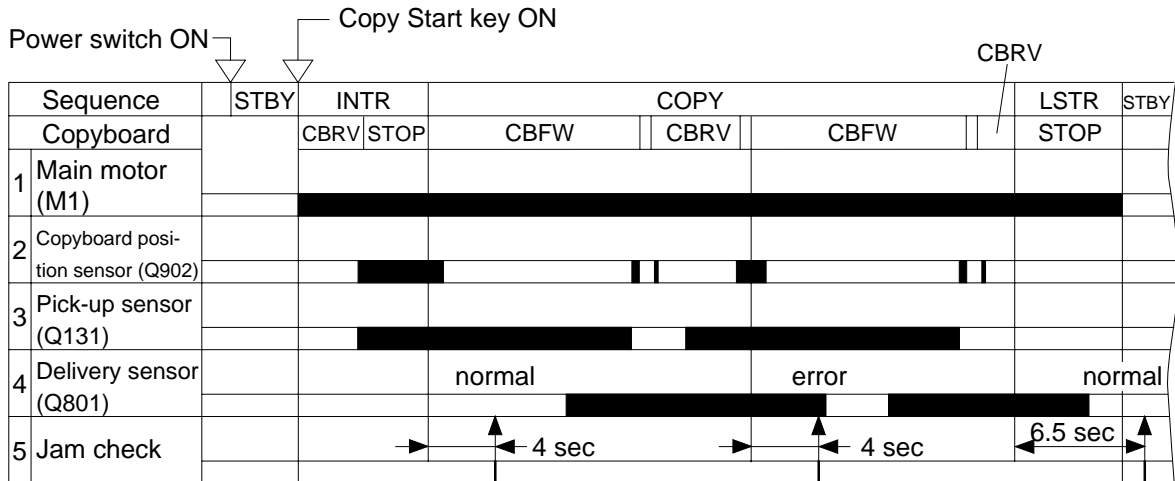

Figure 5-401B (A4)

2. PC400/FC200

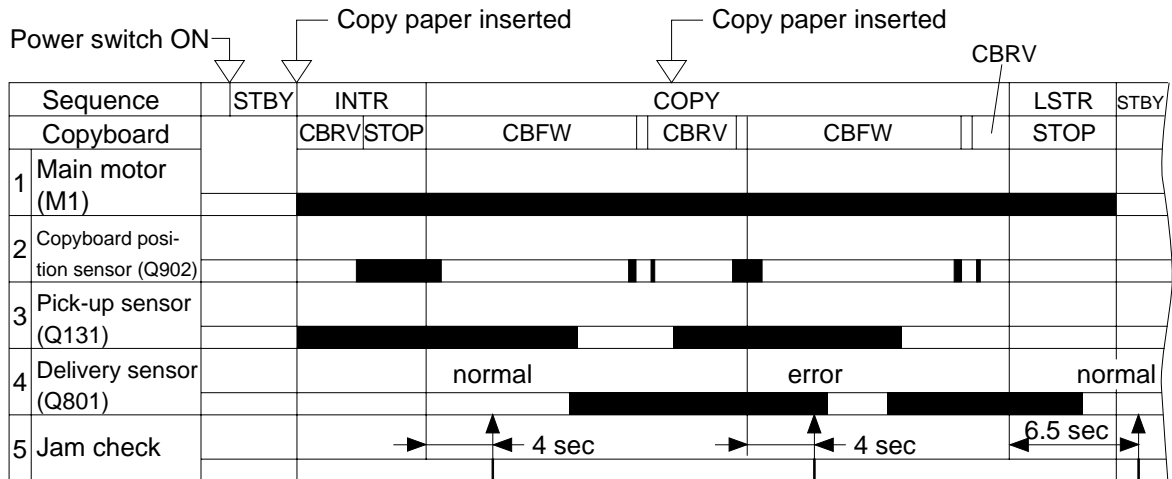
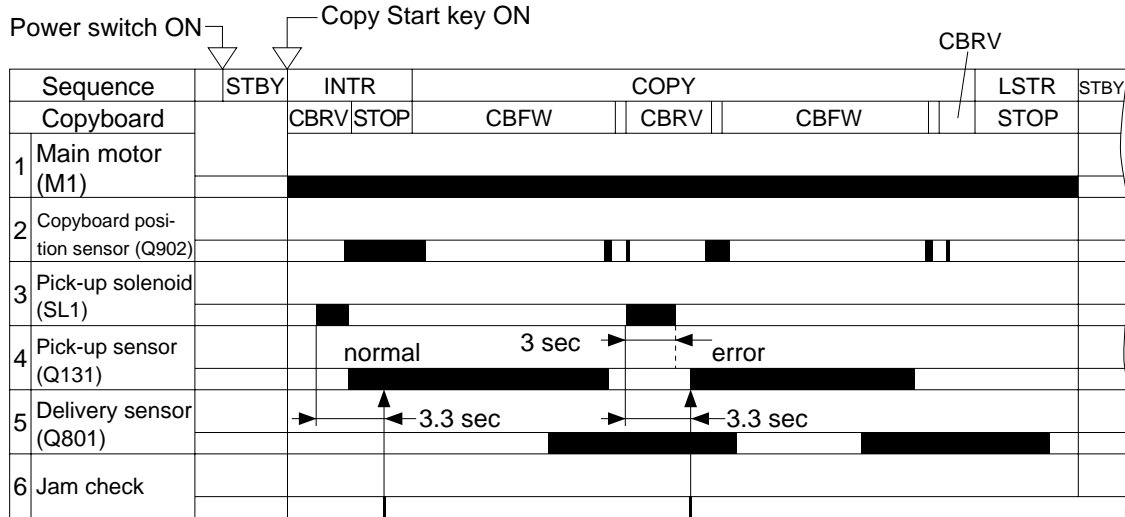

Figure 5-402B (A4)

C. Pick-Up Delay Jam (PC420/430/FC220)

The copy paper does not reach the pick-up sensor within a specific period of time.



Note: A jam is identified if the pick-up sensor is ON 0.2 sec after the pick-up solenoid has gone OFF.

Figure 5-401C

D. Pick-Up Stationary Jam

The copy paper does not move past the pick-up sensor within a specific period of time.

1. PC420/430/FC220

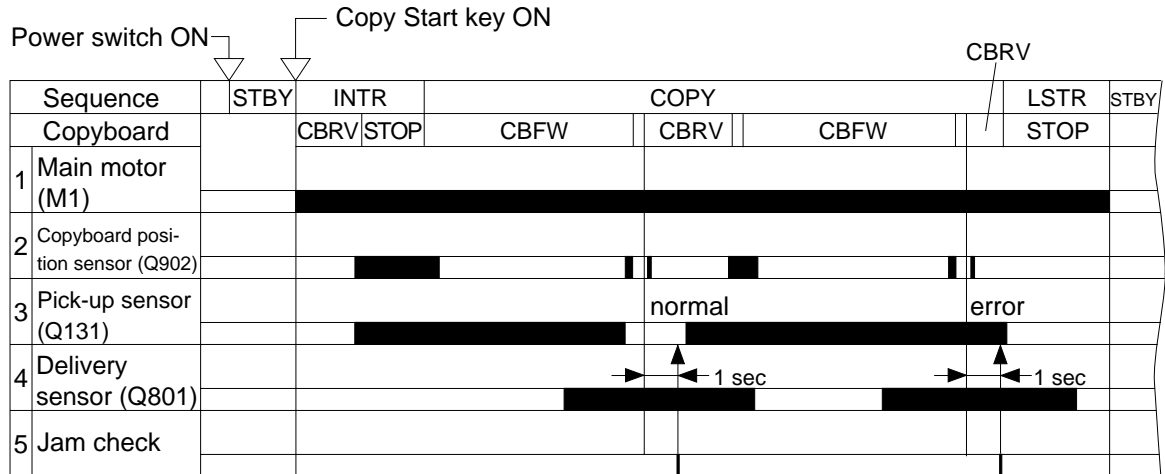

Figure 5-401D (A4)

2. PC400/FC200

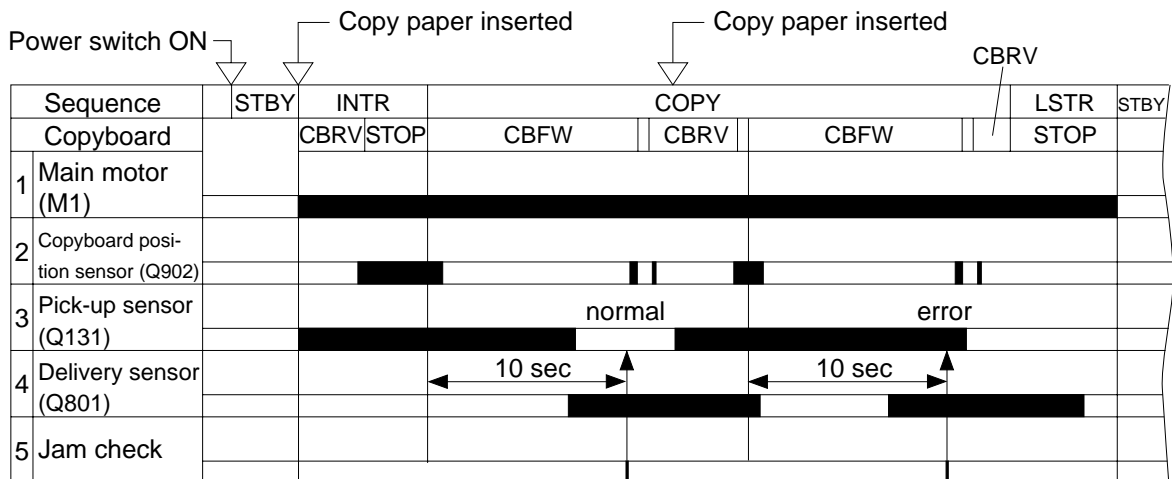

Figure 5-402D (A4)

E. Paper is present at the pick-up or delivery sensor at time of power-on or when the Copy Start key is pressed.

V. MECHANICAL SYSTEM

Here, the copier is discussed in terms of its mechanical characteristics and operation and how to disassemble and assemble it.

Be sure to observe the following for disassembly/assembly work:

1. ▲ Disconnect the power cord for safety before disassembly or reassembly work.
2. Unless otherwise noted, reassembly is the reverse of disassembly.
3. Group the screws by type (length and diameter) and location.
4. One of the mounting screws used on the rear cover is provided with a washer to protect against static electricity. Be sure to keep the washer with the screw when mounting the cover.
5. The fixing screw for the grounding wire and varistors is fitted with a washer to ensure electric continuity; be sure to use the washer for reassembly.
6. If possible, avoid operating the machine with any of its parts removed.

A. Pick-Up Roller Assembly

1. Detaching the Pick-Up Roller

a. PC420/430/FC220

- 1) Detach the body cover.
- 2) Disengage the hook ①, and detach the solenoid ②.

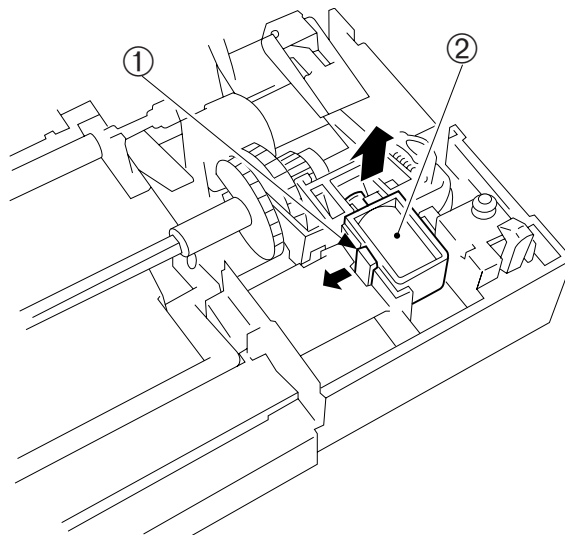

Figure 5-501A (right rear view)

- 3) Remove the spring ③, and detach the claw ④ of the control ring by pulling it up.

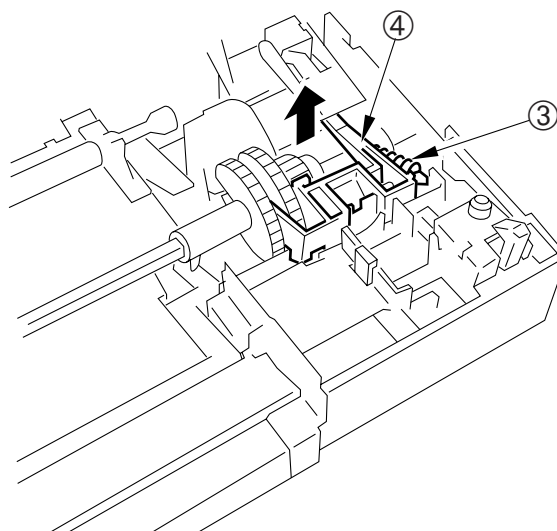

Figure 5-502A

- 4) Bend the holding plate ⑤, and detach the pick-up roller bushing ⑥ by pulling it to the front.

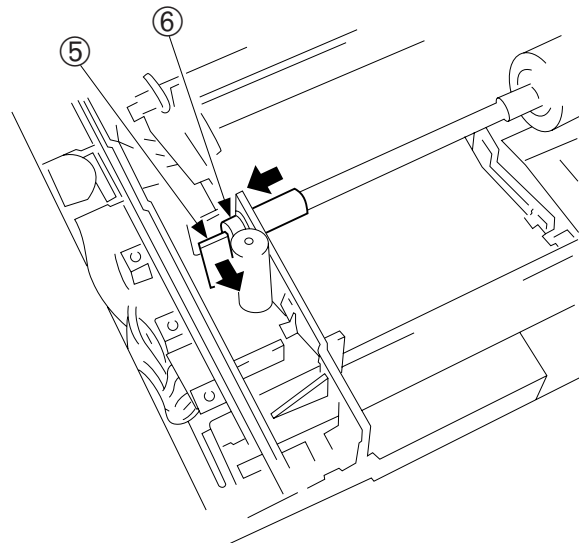

Figure 5-503A

- 5) Move the pick-up roller assembly ⑦ to the front, and detach it from the rear.

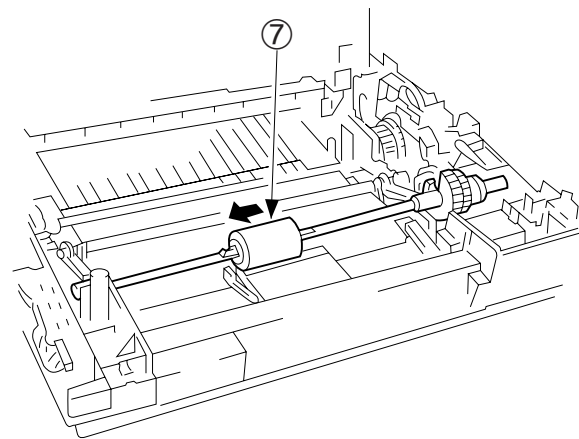

Figure 5-504A

- 6) Disengage the hook ⑧, and detach the pick-up roller ⑩ from the pick-up roller shaft ⑨.

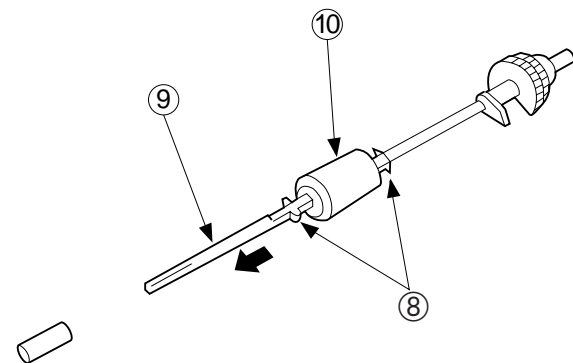

Figure 5-505A

- b. PC400/FC200
- 1) Detach the body cover.
 - 2) Bend the pick-up roller support ①, and detach the pick-up roller ② from the rear by pulling it to the front.

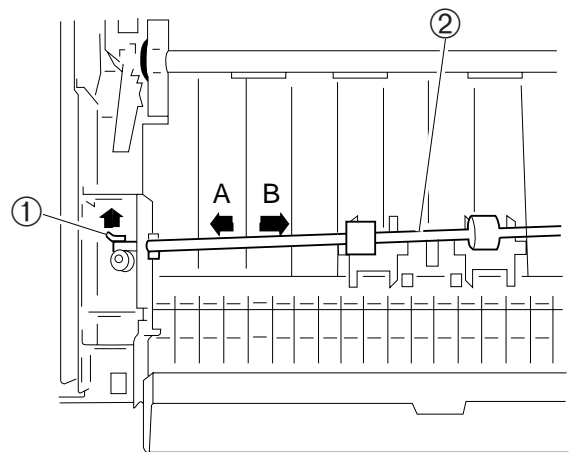

Figure 5-506A

B. Registration Roller Assembly

1. Detaching the Registration Roller Assembly

- 1) Detach the copyboard drive assembly.
- 2) Remove the two screws (M4X10; black) ①, and detach the registration roller assembly ② while lifting its front slightly and as if to move it to the front.

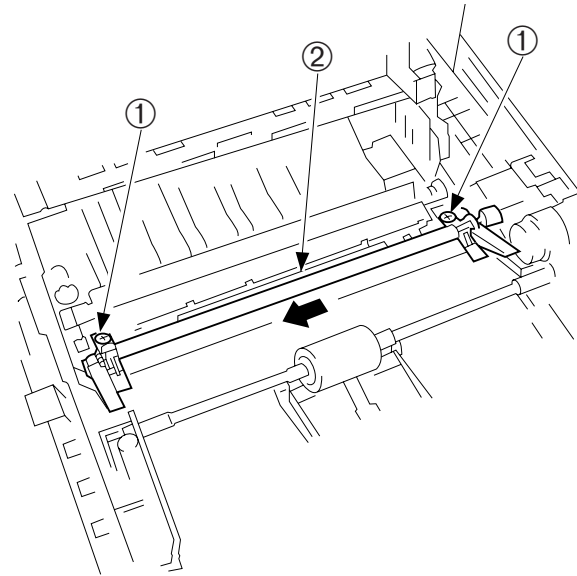

Figure 5-501B

Note:

When installing the registration roller assembly to the copier, be sure that the sheet shown in Figure 5-502B is between the upper and lower registration rollers.

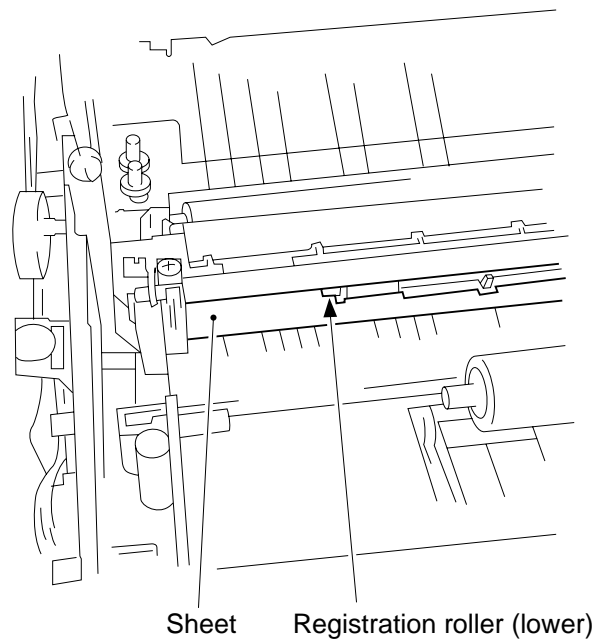

Figure 5-502B

C. Removing the Separation Pad

- 1) Remove the pick-up roller assembly
①.

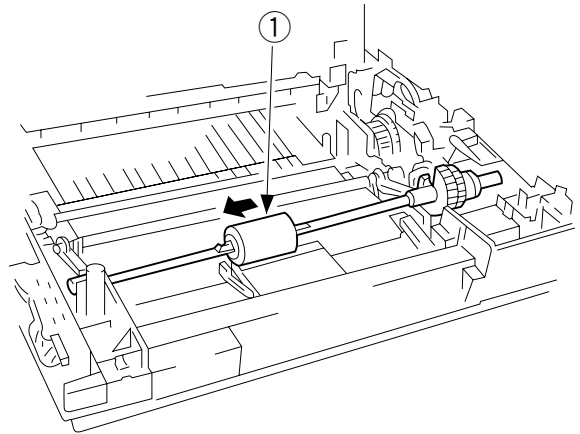

Figure 5-501C

- 2) Open up the feeding guide ②, and remove the separation guide ③.

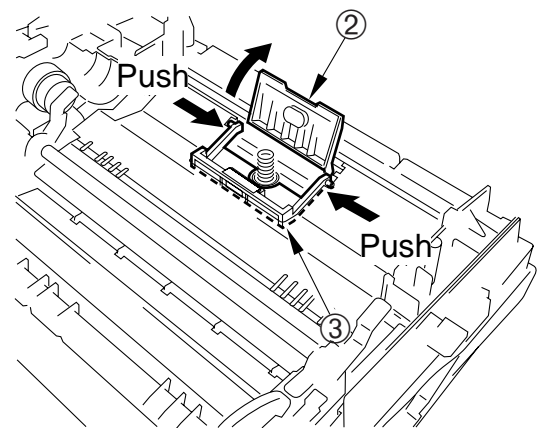

Figure 5-502C

CHAPTER 6

FIXING SYSTEM

This chapter outlines the machine's fixing system in relation to mechanisms and functions, relationship between electrical and mechanical systems, and the timing of operation of respective parts.

I. OUTLINE OF OPERATIONS.....6-1	C. Controlling the Supply Power to the Fixing Heater6-3
A. Outline6-1	D. Protection Mechanisms6-5
B. Controlling the Fixing Heater Temperature.....6-3	II. MECHANICAL SYSTEM.....6-6
	A. Fixing Assembly.....6-7

Blank Page

I. OUTLINE OF OPERATIONS

A. Outline

The pressure roller in the fixing assembly is driven by the main motor (M1).

The rotation of the pressure roller causes the fixing film to rotate.

Some sections of the underside of the fixing film is heated by the fixing heater.

The temperature of the fixing heater is monitored by the thermistor (TH1), and the readings are sent to the microprocessor on the DC controller/DC power supply circuit in the form of the fixing heater temperature sensor signal (TH1).

Based on the signal, the microprocessor of the DC controller/DC power supply circuit controls the temperature of the fixing heater by the fixing heater drive command (HTRD).

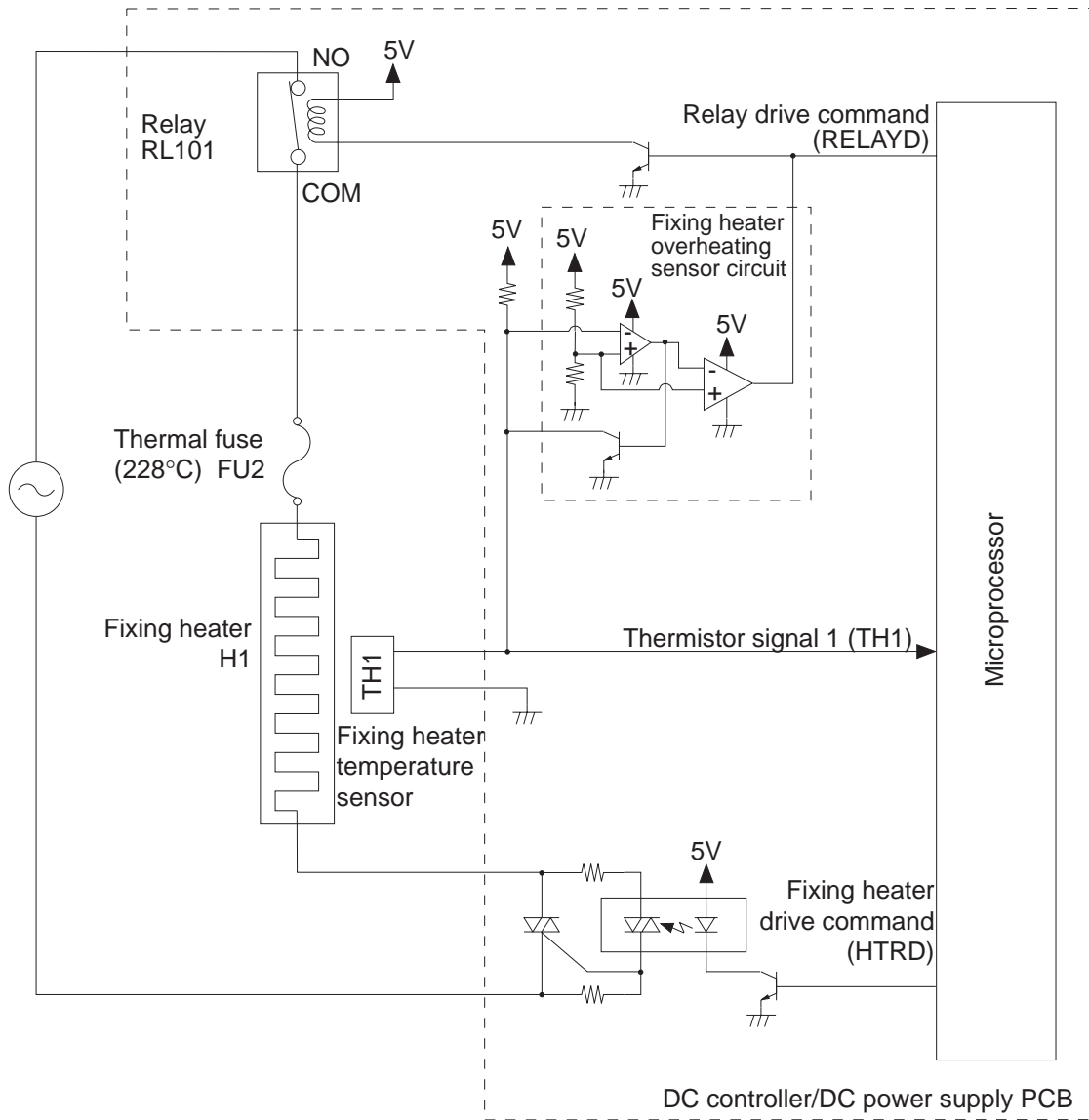

Figure 6-101A

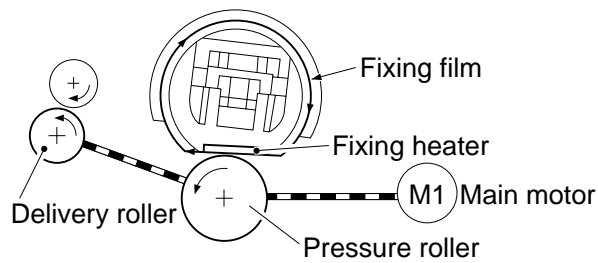

Figure 6-102A

B. Controlling the Fixing Heater Temperature

The target temperature for the fixing heater is controlled to four settings (155°, 165°, 175°, 185°C) by the microprocessor based on the following conditions:

- a. Temperature of the fixing heater at time of power-on (185°C if 90°C or less; 165°C if otherwise)
- b. Temperature of the fixing heater at time of copy-start (185°C if 90°C or less; as needed to suit the number of copies made if otherwise)
- c. Number of copies made:
 - 185°C if copy
 - 175°C if for 2 to 4 copies
 - 165°C if for 5 to 15 copies
 - 185°C if for 16 copies or more

C. Controlling the Supply Power to the Fixing Heater

The temperature of the fixing heater (H1) is controlled by controlling the power supplied to the fixing heater.

The power to the fixing heater is controlled by a phase power control method.

The microprocessor on the DC controller/DC power supply circuit takes on the zero-cross signal (ZXDP) from the zero-cross signal generator circuit as a sync signal to identify the AC input voltage in relation to the reference voltage signal (VPEAK) from the reference voltage sensor circuit.

Using the reading, the microprocessor controls the fixing heater drive command (HTRD) power to attain the specific target temperature for the fixing heater, in other words exerting phase control on the supply power to the fixing heater.

Further, 'E9' is indicated on the control panel if the zero cross signal (ZXDP) falls below a specific value because of an error in the frequency of the power supply.

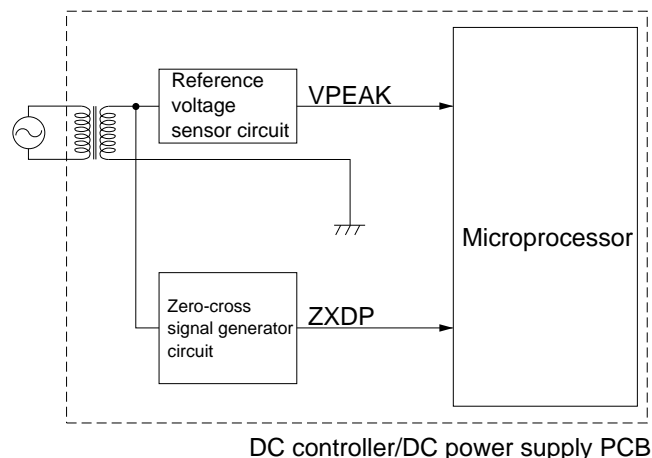

Figure 6-101C

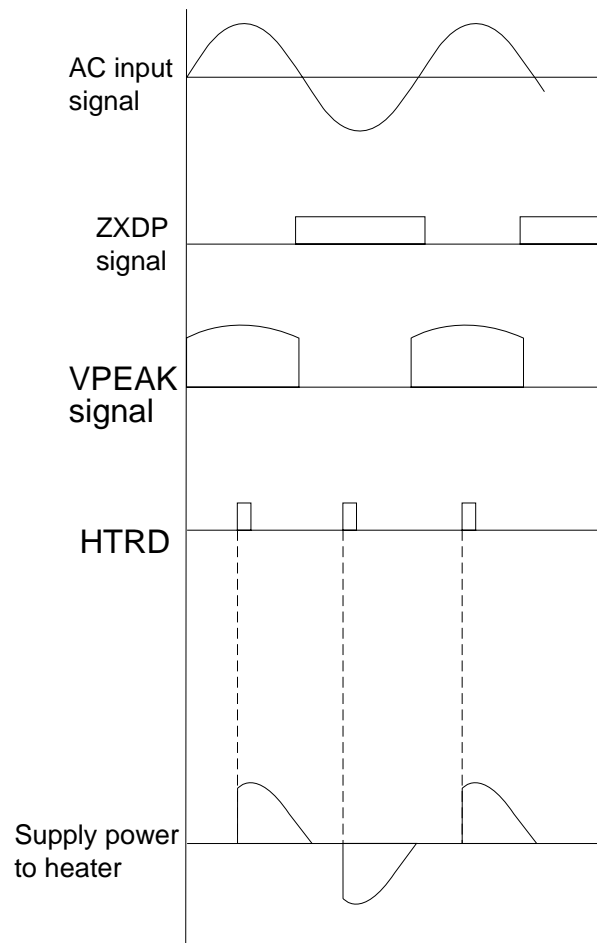

Figure 6-102C

D. Protection Mechanisms

The copier is equipped with the following protection mechanisms to prevent malfunction of the fixing heater.

- 1. The microprocessor monitors the voltage of TH1, and displays 'E0' (PC420/430/FC220)/ 'Jam' (PC400/FC200) and turns the power off upon detection of any of the following conditions:**
 - i. The temperature of the fixing heater does not reach 80°C 2.5 sec. after copying starts.
 - ii. The temperature of the fixing heater does not reach 150°C within 7.5 sec. after copying starts.
 - iii. The temperature of the fixing heater drops to 135°C or less after it has reached 150°C.
 - iv. The temperature of the fixing heater rises in excess of 215°C.
 - v. The maximum power (400 W) is detected for 5 sec. continuously after the temperature of the fixing heater has reached 150°C.
- 2. TH1 registers 234°C as the temperature of the fixing heater; as a result, the fixing heater error temperature detection circuit causes RELAYD to go '0' and the relay (RL101) to go OFF, thereby cutting the power to the fixing heater.**
- 3. The thermal fuse (FU2) blows after it has reached 228°C and a specific time has passed to cut off the power to the fixing heater.**

II. MECHANICAL SYSTEM

Here, the copier is discussed in terms of its mechanical characteristics and operation and how to disassemble and assemble it.

Be sure to observe the following for disassembly/assembly work:

1. ▲ Disconnect the power cord for safety before disassembly or reassembly work.
2. Unless otherwise noted, reassembly is the reverse of disassembly.
3. Group the screws by type (length and diameter) and location.
4. One of the mounting screws used on the rear cover is provided with a washer to protect against static electricity. Be sure to keep the washer with the screw when mounting the cover.
5. The fixing screw for the grounding wire and varistors is fitted with a washer to ensure electric continuity; be sure to use the washer for reassembly.
6. If possible, avoid operating the machine with any of its parts removed.

A. Fixing Assembly

1. Construction

Note:

1. The fixing film is made of special material; do not touch it or leave dust on it.
2. The pressure exerted by the lower roller is controlled by the pressure spring built into the bushing.
3. The copier does not have an adjustment mechanism for roller pressure.

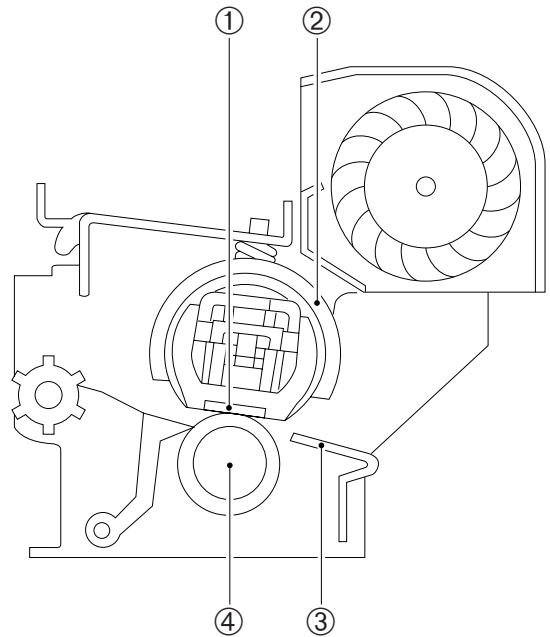

- | | |
|-----------------|----------------------------------|
| ① Fixing heater | ④ Pressure roller (lower roller) |
| ② Fixing film | |
| ③ Inlet guide | |

Figure 6-201A

2. Detaching the Fixing Assembly

- 1) Detach the body cover.
- 2) Disconnect the three connectors ①.

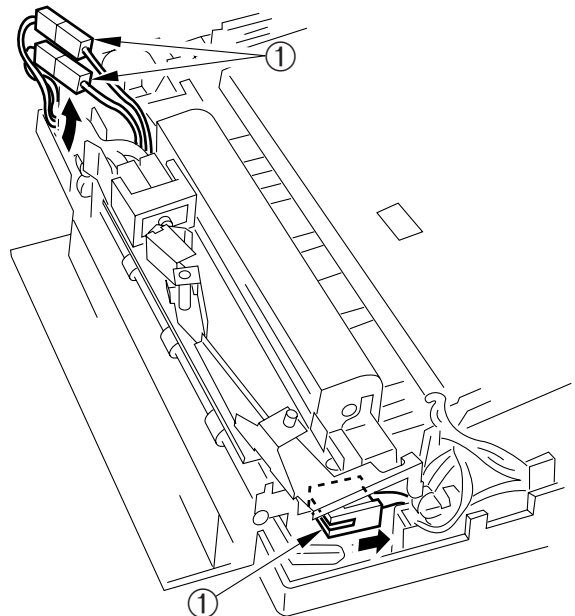

Figure 6-202A

- 3) While lifting the hook ②, slide the delivery door switch ③ to the front to remove.

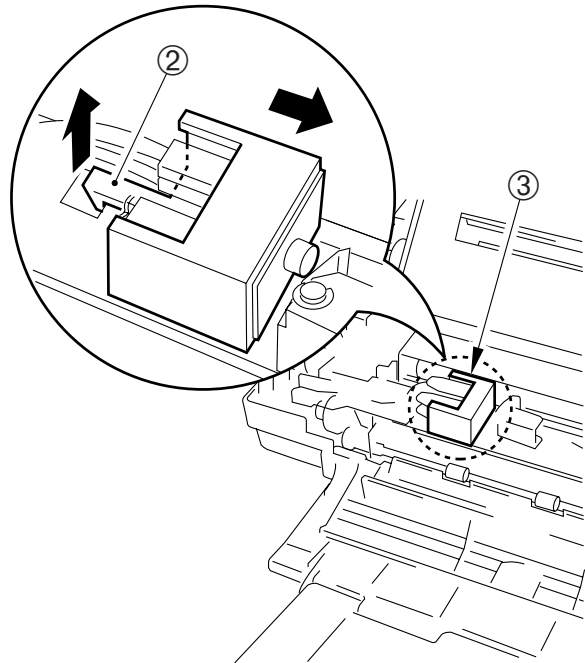

Figure 6-203A

- 4) Detach the drive belt ④.

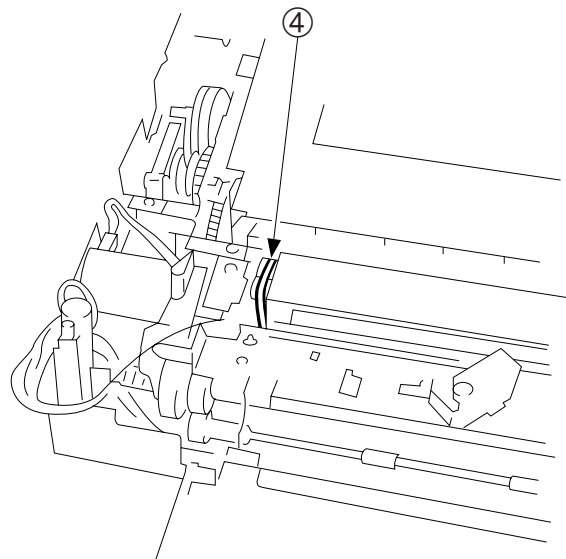

Figure 6-204A

- 5) Remove the two screws (M4X8; yellow) ⑤, and turn the fixing assembly ⑥ slightly in the direction of the arrow to remove.

Caution:

1. You cannot replace the fixing film or fixing heater; do not disassemble them.
2. Do not forget to attach the drive belt of the heat exhaust fan to the pulley when attaching the fixing assembly.

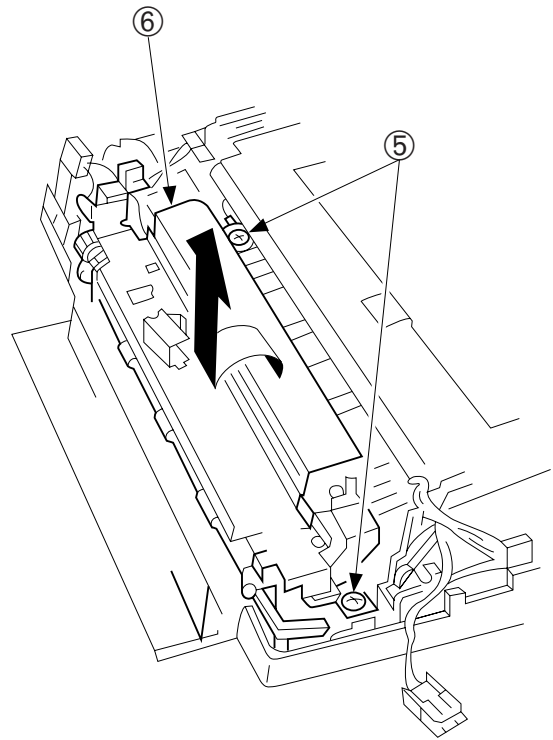

Figure 6-205A

3. Removing the Fixing Upper Unit

- 1) Remove the fixing assembly.
- 2) Remove the harness ①, and remove the hook ②; then, remove the harness holder ③.

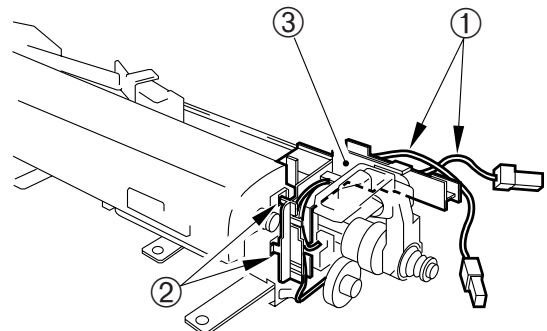

Figure 6-206A

- 3) Remove the two hooks ④, and remove the drive releasing arm ⑤.

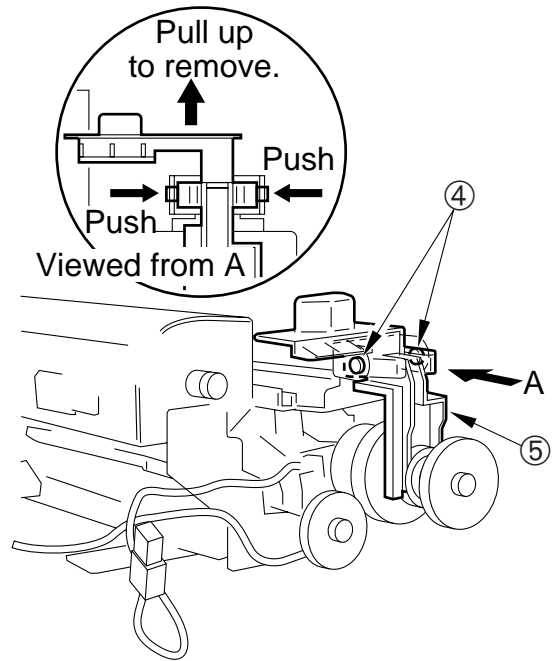

Figure 6-207A

- 4) Remove the two screws ③, and remove the heat exhaust fan ④.

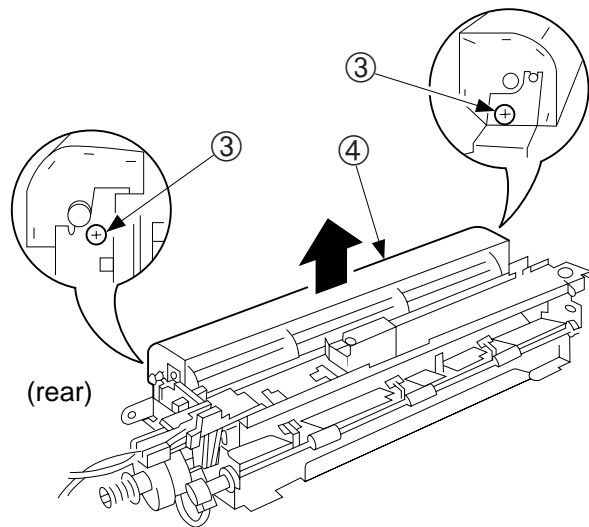

Figure 6-208A

- 5) Remove the two screws ⑦, and turn the upper stay ⑧ in the direction of the arrow to remove.

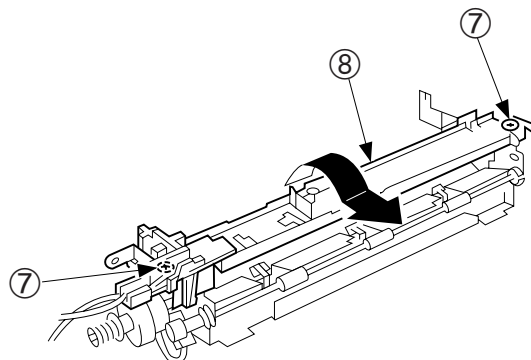

Figure 6-209A

- 6) Disconnect the connector ⑨, and remove the fixing upper unit ⑩.

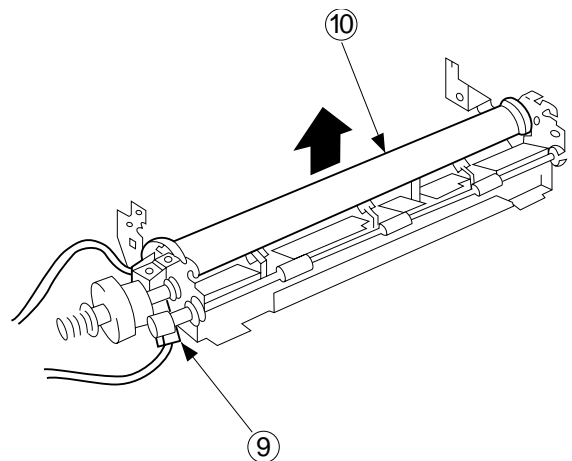

Figure 6-210A

4. Detaching the Pressure Roller

- 1) Detach the fixing upper unit.

Note:

Take care not to damage the pressure roller by the separation claw or inlet guide when detaching it.

- 2) Detach the pressure roller ① as if to lift it.

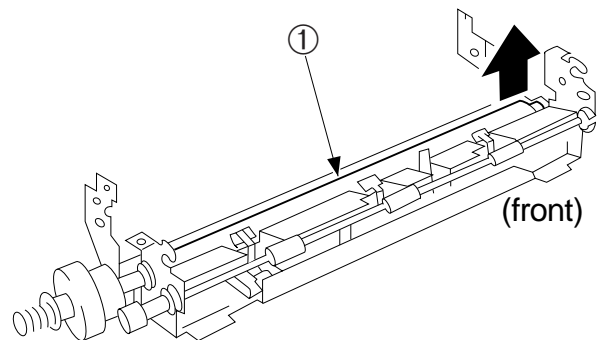

Figure 6-211A

CHAPTER 7

EXTERNALS/AUXILIARY MECHANISMS

This chapter outlines the machine's auxiliary system in relation to mechanisms and functions, relationship between electrical and mechanical systems, and the timing of operation of respective parts.

I. POWER SUPPLY	7-1	A. External Covers	7-4
A. Outline	7-1	B. Copyboard Assembly	7-9
B. Power Supply PCB	7-2	C. DC Controller/DC Power Supply PCB	7-11
C. Protection Mechanism for Power Supply Circuit	7-2	D. Control Panel PCB	7-14
II. MECHANICAL SYSTEM	7-3		

Blank Page

I. POWER SUPPLY

A. Outline

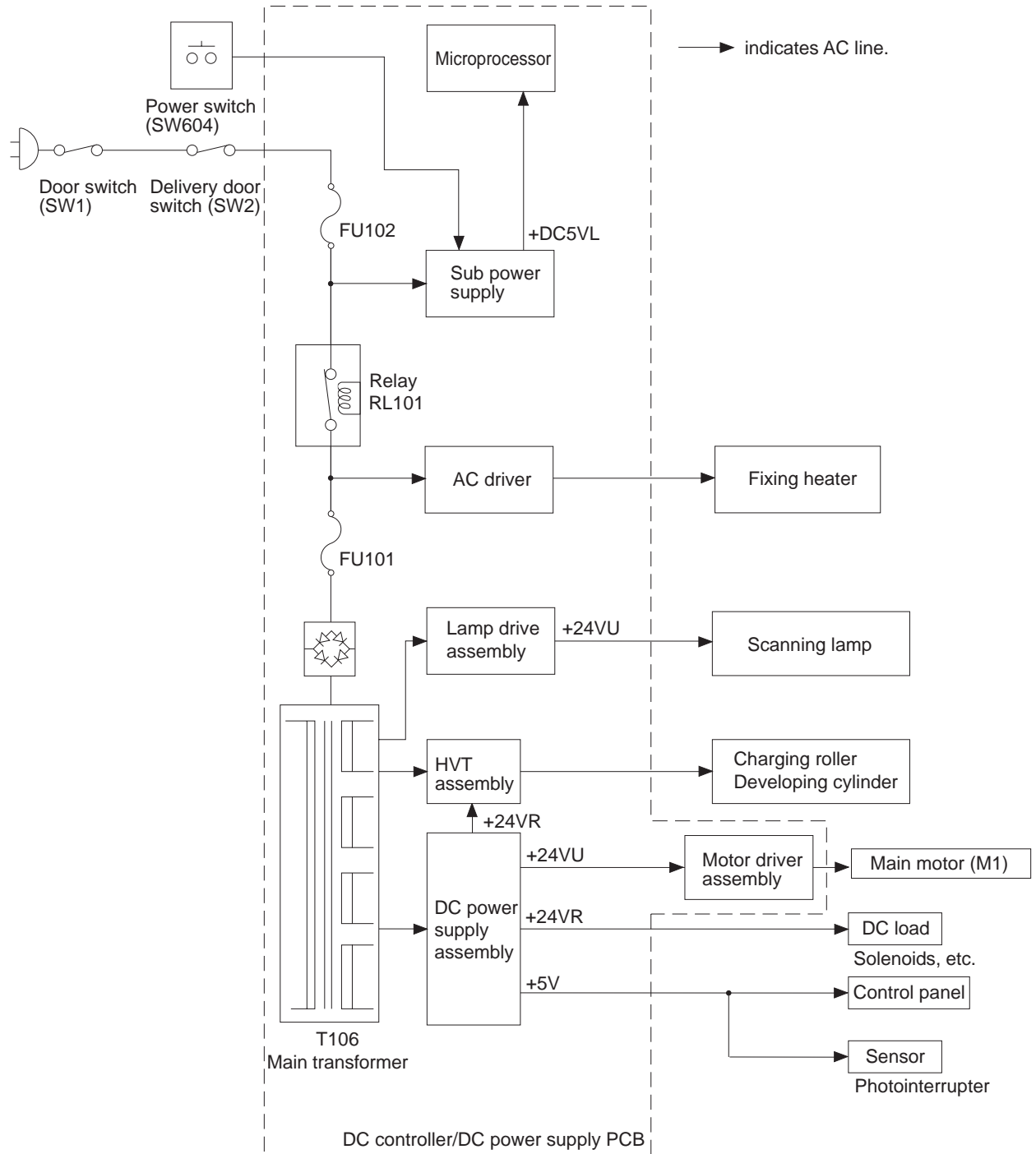

Figure 7-101A

B. Power Supply PCB

The copier's power supply is a composite power supply in which one main transformer (T106) supplies DC power as well as power for high voltage and scanning lamp.

AC power is supplied to the DC power supply when the power switch and door switch are turned ON.

The DC power supply generates +24 V and +5 V.

For auto power-off, the microprocessor causes the relay (RL101) to go OFF, thus cutting power supply.

The copier is equipped with a sub power supply which provides the microprocessor with +5VDC power for about 5 minutes after a condition associated 'E0' occurs; during this period, the copier is prevented from going ON to prevent damage by overheating the fixing heater.

Note:

The tolerances for the DC power supply are as follows:

- +24VR \pm 5%
- +24 VU : +22 V to +46 V
- +5 VL \pm 2%
- +5 V \pm 10%

C. Protection Mechanism for Power Supply Circuit

The DC power supply circuit's AC power supply input is equipped with a fuse. The fuse blows if an overcurrent flows because of a short circuit in the 24V power, thus shutting out the output from the AC power supply circuit. If this happens, disconnect the copier's power cord, correct the cause of the problem, and replace the fuse.

If the microprocessor detects an error on the AC or 24VDC line of the main transformer (T106), it causes the relay to go OFF, thus cutting the power output. If this happens, remove the cause and switch the copier ON to reset.

II.MECHANICAL SYSTEM

Here, the copier is discussed in terms of its mechanical characteristics and operation and how to disassemble and assemble it.

Be sure to observe the following for disassembly/assembly work:

1. ▲ Disconnect the power cord for safety before disassembly or reassembly work.
2. Unless otherwise noted, reassembly is the reverse of disassembly.
3. Group the screws by type (length and diameter) and location.
4. One of the mounting screws used on the rear cover is provided with a washer to protect against static electricity. Be sure to keep the washer with the screw when mounting the cover.
5. The fixing screw for the grounding wire and varistors is fitted with a washer to ensure electric continuity; be sure to use the washer for reassembly.
6. If possible, avoid operating the machine with any of its parts removed.

A. External Covers

Detach the covers as follows to clean, inspect, or repair the inside of the machine.

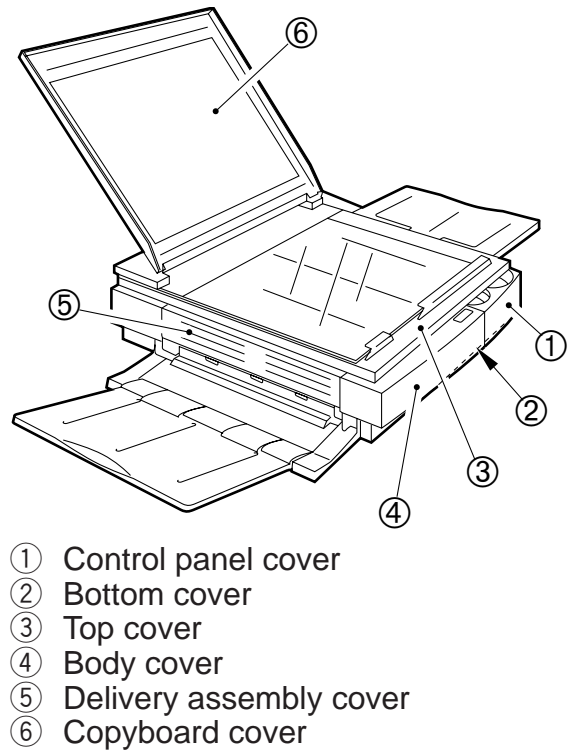

- ① Control panel cover
- ② Bottom cover
- ③ Top cover
- ④ Body cover
- ⑤ Delivery assembly cover
- ⑥ Copyboard cover

Figure 7-201A

1. **Detaching the Control Panel Cover**
 - 1) Move the copyboard cover to the left until it stops.
 - 2) Open the top cover, and remove the screw ①.
 - 3) Detach the control cover ② as if to lift it to the front.

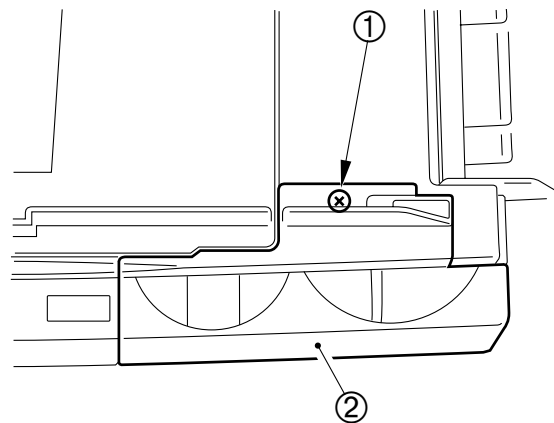

Figure 7-202A

Note:

When attaching the PC400/FC200 control panel cover, fit the VR on the control panel PCB into the groove of the density control lever.

2. Detaching the Body Cover

- 1) Detach the copyboard.
- 2) Detach the two cover plates ① by pulling them up.

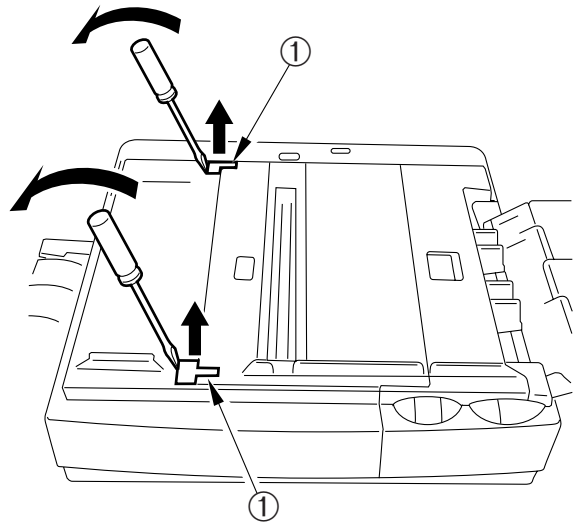

Figure 7-203A

- 3) Detach the pick-up tray and delivery tray.
- 4) Detach the control cover.
- 5) Open the top cover, and take out the cartridge.
- 6) Press the delivery assembly cover open/close button to open the delivery cover.

Note:

You must disengage the five hooks that hold the body cover in place before detaching the body cover.

- 7) Push the hook found down the hole ③ in the body cover ② with a screwdriver, and lift the body cover slightly.

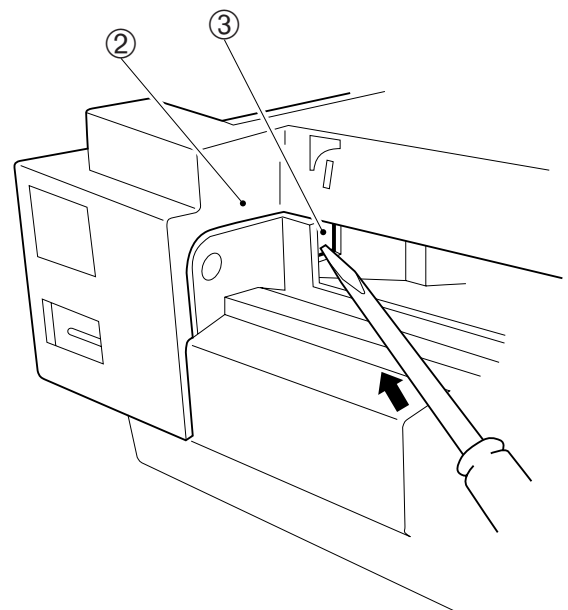

Figure 7-204A (right view)

- 8) Push the hook ④ found at the right rear of the body with a screwdriver, and lift the body cover ⑤ slightly.

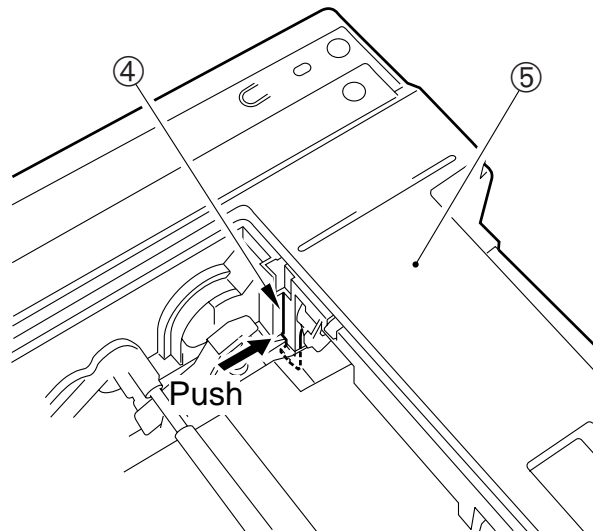

Figure 7-205A (right rear view)

- 9) Detach the hook at the rear ⑥ as if to pull the body cover ⑦ to the front; then, lift the body cover slightly.

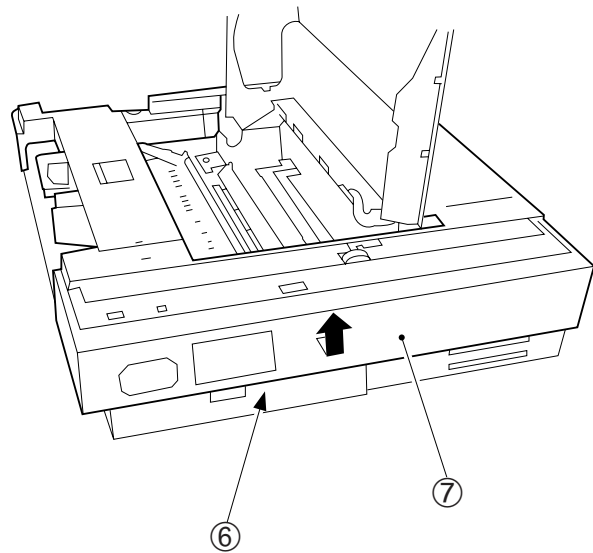

Figure 7-206A (rear view)

- 10) Disengage the two hooks at the front ⑧ as if to pull the body cover to the front.
 11) Detach the body cover ⑨ by lifting it.

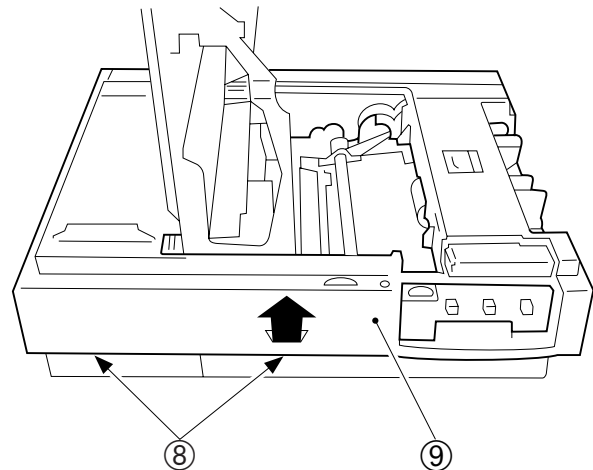

Figure 7-207A

3. Detaching the Top Cover

Assembly

- 1) Detach the body cover.
- 2) Disconnect the two connectors ①.

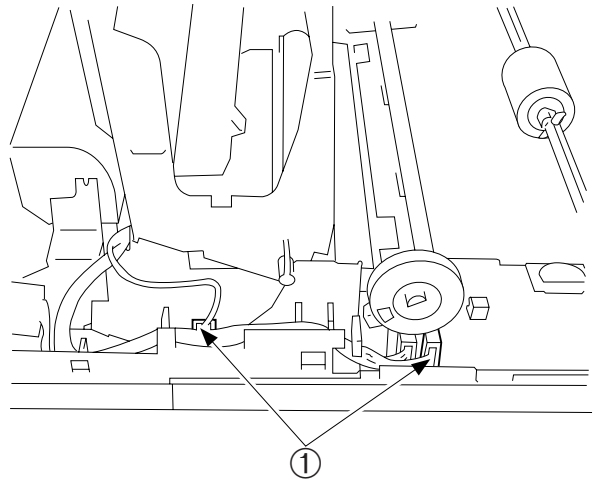

Figure 7-208A

- 3) Bend the support ② at the front to the front, and remove the pin ③ from the top cover assembly.
- 4) Detach the top cover assembly ④.

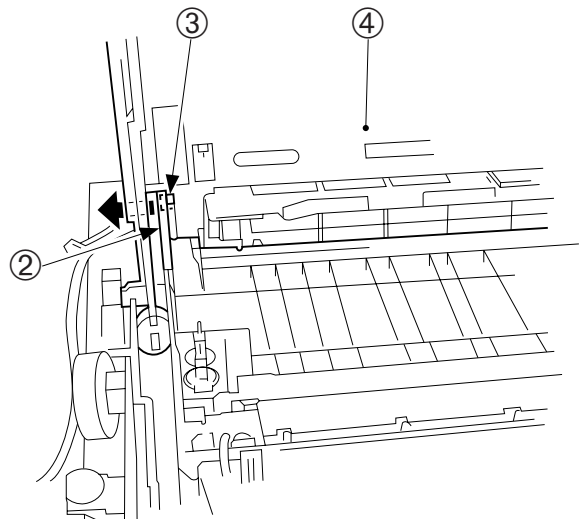

Figure 7-209A

4. Detaching the Delivery Assembly Cover

- 1) Take out the fixing assembly.
- 2) Shift the delivery assembly cover ① in the direction of "close," and match the D-cut ② of the hinge with the cut in the bushing; then, remove it from the front.

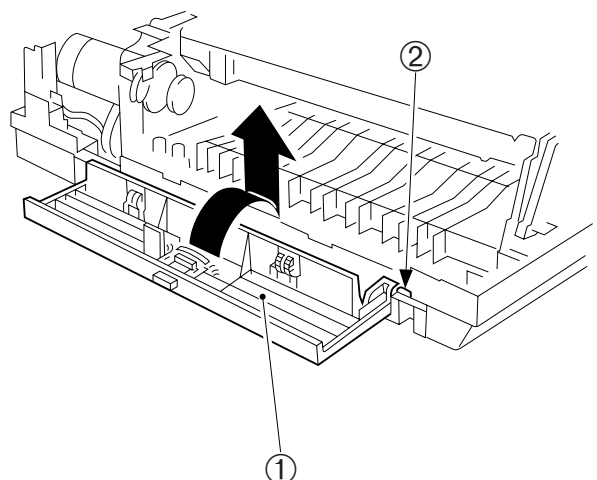

Figure 7-210A

5. Detaching the Bottom Cover

- 1) Place the copier with the delivery assembly at the bottom; then, remove the two screws (M4X10; black) ①.
- 2) Disengage the five hooks ②, and detach the bottom cover ③.

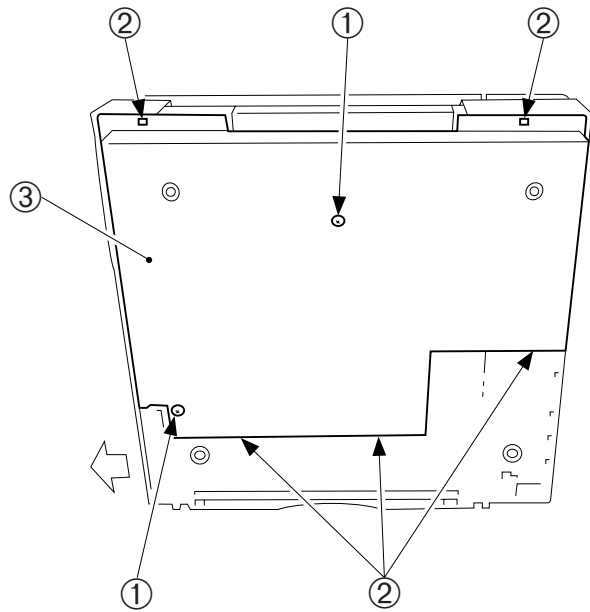

Figure 7-211A

B. Copyboard Assembly

1. Detaching the Copyboard Cover

- 1) Lift the right rear corner of the copyboard cover about 5 mm; then, slide it to the front.

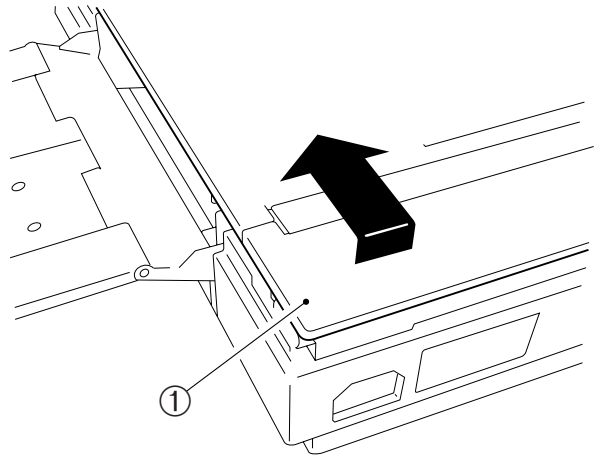

Figure 7-201B

- 2) Slide the left rear corner the same way.

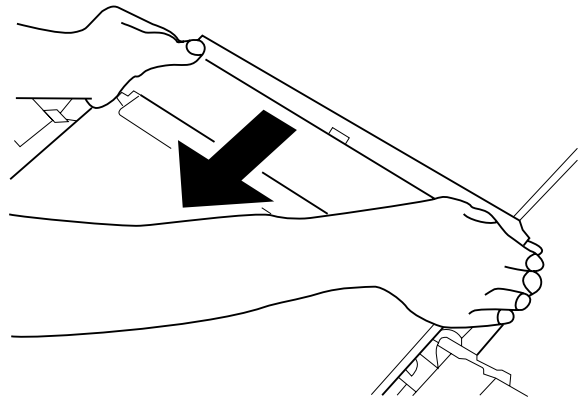

Figure 7-202B

2. Detaching the Copyboard

- 1) Move the copyboard ① to the left until it stops, and remove the screws (②, M3X6, white; ③, M4X10, black).

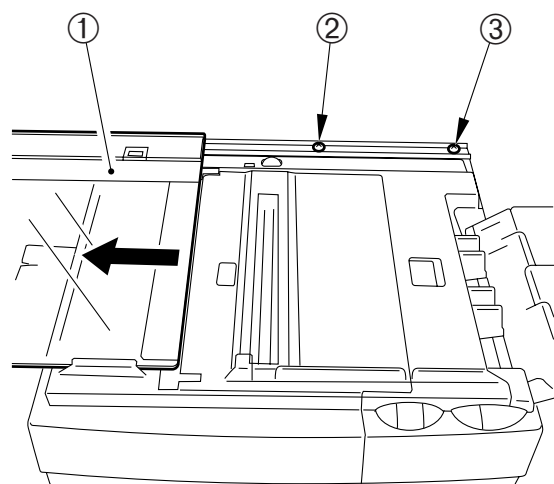
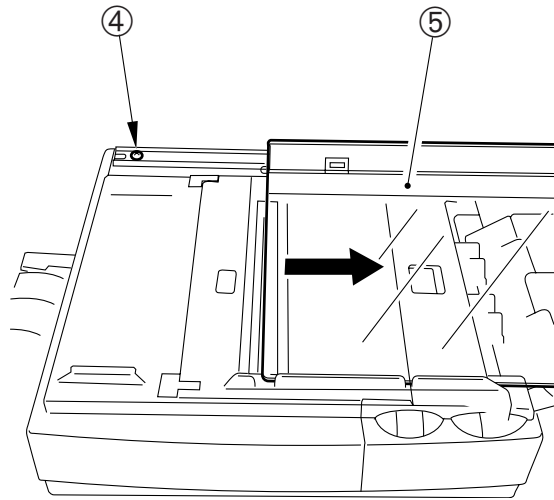

Figure 7-203B

- 2) Move the copyboard to the right by hand, and remove the screw (M4X10; black) ④; then, detach the copyboard ⑤.

**Figure 7-204B****Note:**

1. Do not disassemble the rail.
2. To attach the copyboard, fit the copyboard glass into the rail at the front, and screw the rear rail portion in place.

C. DC Controller/DC Power Supply PCB

1. Detaching the DC Controller/DC Power Supply PCB

- 1) Detach the body cover.
- 2) Remove the drive release arm ①.
- 3) Remove the screw ②, and disconnect the two connectors ③.
- 4) Disconnect the four fastons ④.
- 5) Detach the bottom cover.

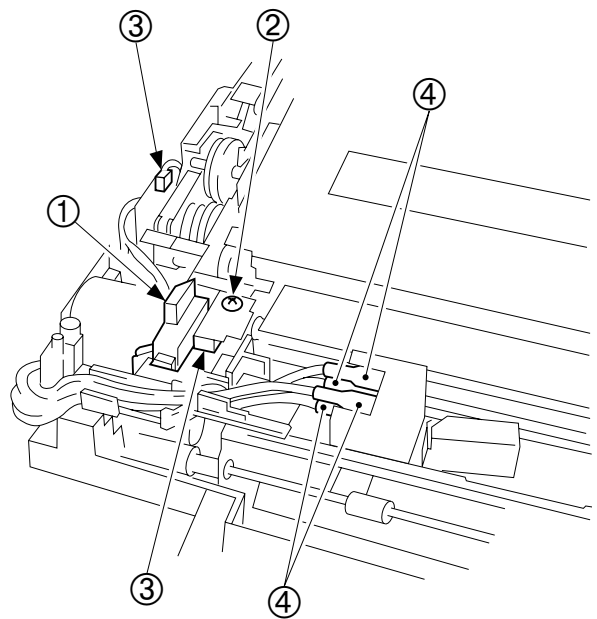

Figure 7-201C

- 6) Hold the flat cable ⑤ with both hands, and detach them from the connector by lifting them straight up.
- 7) Disconnect the connector ⑥.

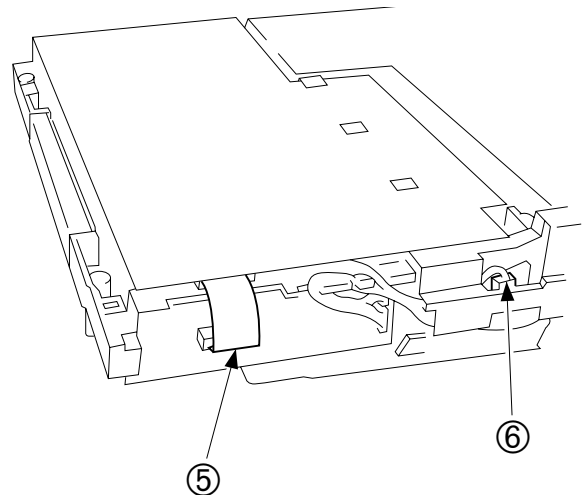

Figure 7-202C (front)

- 8) Disconnect the two connectors ⑦ at the rear, and detach the grounding wire ⑧.

Caution:

The DC controller/DC power supply PCB has high-voltage contacts and pick-up sensor lever; take extra care not to damage the parts when detaching the PCB.

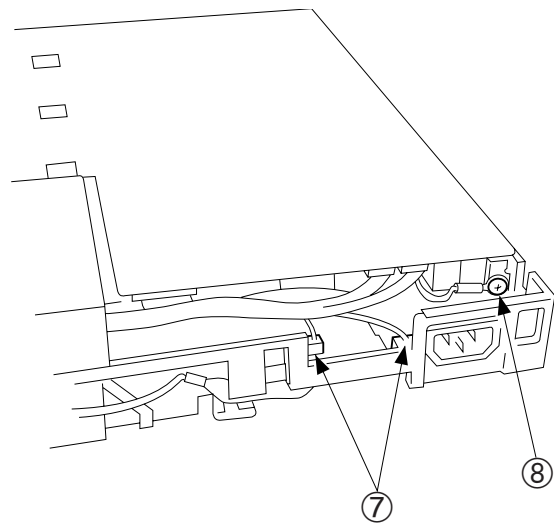

Figure 7-203C

- 9) Remove the screw (M4X8; yellow) ⑨, and disengage the hook ⑩; then, detach the DC controller/DC power supply PCB ⑪.

Caution:

When attaching the DC controller/DC power supply PCB, make sure that lead wires are not bitten or shorted, or the connectors are not disconnected.

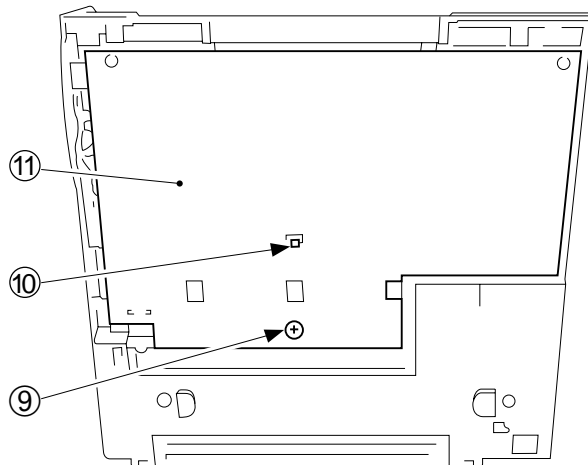

Figure 7-204C

2. Points to Note When Installing the Delivery Door Switch

Caution:

When inserting the fastons into the door switch, make sure that the correct fastons are connected as identified by color (Figure 7-205C).

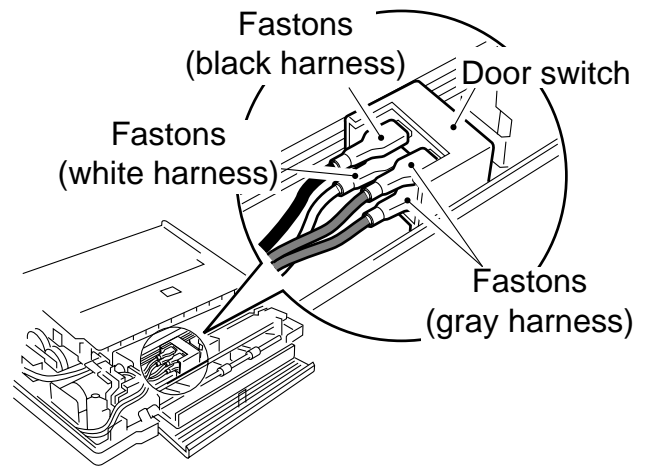

Figure 7-205C

D. Control Panel PCB

Note:

You must adjust the VR for intensity and AE (PC420/430/FC220) after replacing the control panel PCB.

1. Detaching the Control Panel PCB

- 1) Detach the body cover.
- 2) Disconnect the three connectors ①.
- 3) Hold the flat cable ② with both hands, and detach them from the connector by lifting them straight up.
- 4) Disengage the hook ③, and detach the control panel PCB ④ by pulling it up.

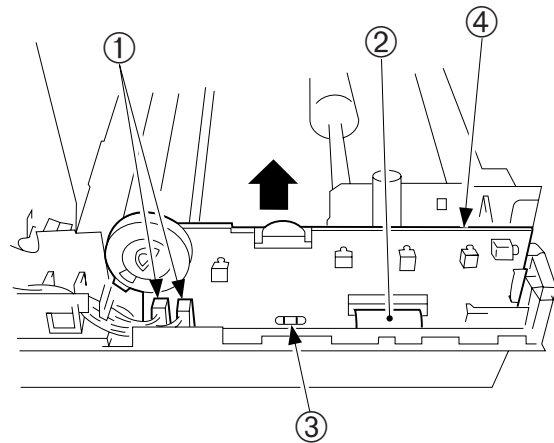

Figure 7-201D

CHAPTER 8

INSTALLATION

This chapter outlines how to install the machine.

The product is carefully adjusted and strictly inspected before it leaves the factory; therefore, proper installation is very important in maintaining its out-of-factory performance. Make sure that all the conditions discussed in this chapter are satisfied before installation, and carry out all necessary inspections after installation.

I. SELECTING THE SITE	8-1	III. RELOCATING THE MACHINE	8-5
II. UNPACKING AND INSTALLATION	8-2		

Blank Page

I. SELECTING THE SITE

Make the following considerations when selecting the site for the machine. It is a good idea to visit the site before delivery of the machine.

- The site should provide an exclusive power outlet with a grounding terminal.
- The temperature and humidity of the site must be 7.5° to 32.5°C/45.5° to 90.5°F and 5% to 85%, respectively. Avoid areas near water faucets, water boilers, humidifiers, or refrigerators.
- Avoid areas near open fires and areas subjected to dust, ammonium gas, or sunlight. If necessary, provide curtains.
- The site must be well ventilated.
- The floor must be level, ensuring all copier's feet will remain in contact.
- The copier must be at least 3.9 in. from all walls, enabling sufficient space for maintenance and copying work.

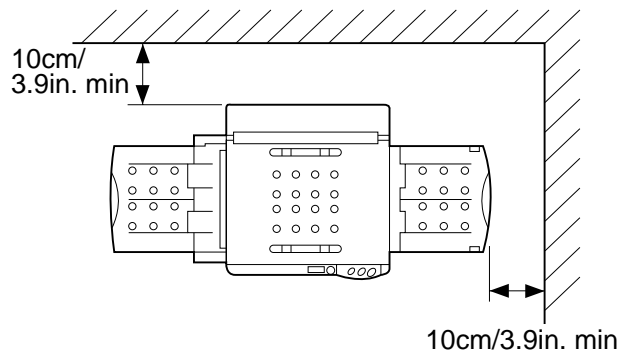
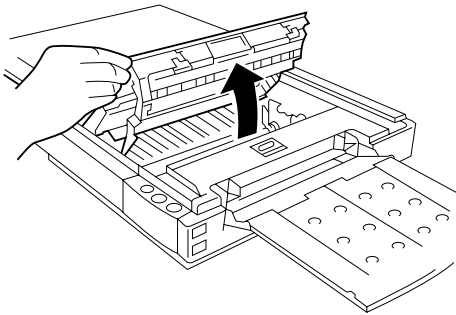
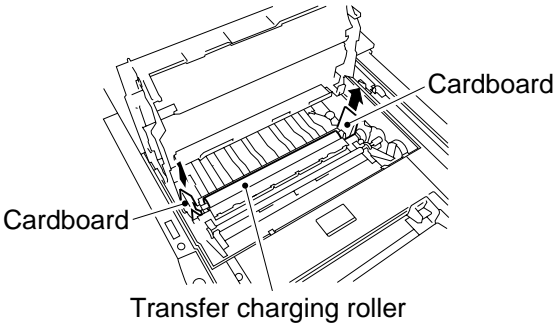
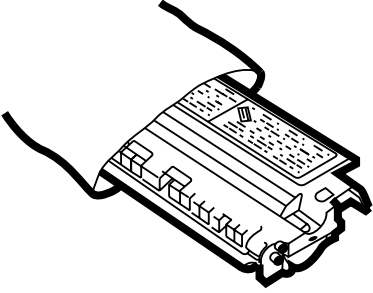
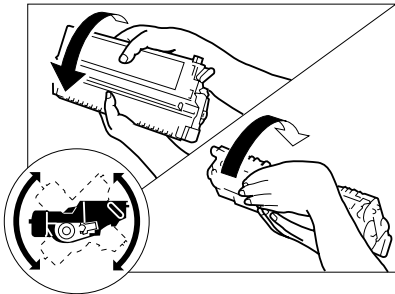
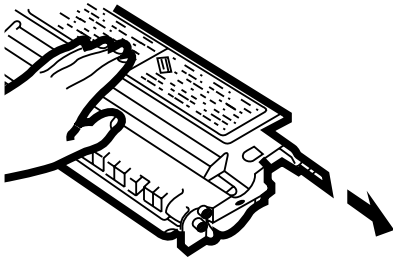
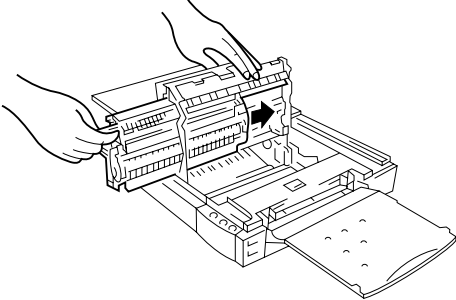
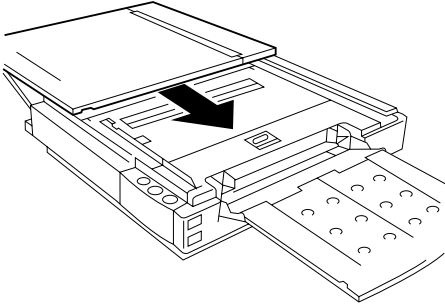

Figure 8-101

II. UNPACKING AND INSTALLATION

Moving a metal object from a cold to warm place can cause droplets of water to appear on its surface. The phenomenon is known as *condensation*, and condensation in the copier can trigger such problems as blank copies. If any such problem is expected, leave the copier alone at the site of installation at least one hour before unpacking it.

Step	Work	Description
1	Open the shipping carton.	
2	Take out the accessories.	Make sure that the Operator's Manual is in the box.
3	Remove the cover bag from the copier, and detach all strips of tape that hold parts.	<ul style="list-style-type: none"> • Check the covers for damage and deformation caused during transit. • Slide out the manual feed tray. • Slide out the delivery tray.
4	Move the copyboard to the left until it stops, and press the open/close button to open the copier's top cover.	
5	Pull the two cardboard pieces, if found inside the copier at either end of the charging roller, straight up and out of the copier. Note: Do not touch the transfer charging roller inside the copier.	
6	Take out the cartridge from the bag. (If the cartridge is installed in the copier, pull it out to the front.)	

Step	Work	Description
7	Hold the cartridge with its Warning label facing up, and rotate it in both directions about 90°.	
8	Place the cartridge on a level place; then, detach the tip of the seal, and pull it fully out (about 50 cm).	
9	Hold the cartridge with its Warning label facing left, and slide in the cartridge slowly until it stops.	
10	Close the top cover, and return it to the center.	

Step	Work	Description
11	Connect the power cord to the power outlet and the copier, and switch the copier ON.	<ul style="list-style-type: none"> • Press the +, Clear/Stop, and other keys to make sure that the copy count is correctly indicated (PC420/430/FC220). • Check that '1' goes ON on the display (PC420/430/FC220). • Check that '1' goes ON on the display (PC420/430/FC220). • Check the Main indicator goes ON (PC400/FC200). • Check the movement of the copy density lever/dial.
12	Set the Test Sheet on the copyboard, and make copies; make sure that copies are made properly.	<ul style="list-style-type: none"> • Make sure no abnormal noise is heard. • Make sure that copies are made in the specified number properly (PC420/430/FC220). • Check that 'P' is indicated when the Copy Start key is pressed without setting copy paper (PC420/430/FC220).
13	Clean the exterior of the copier and the area around it.	

III. RELOCATING THE MACHINE

If you must relocate the machine by truck or other means of transportation, perform the following:

Step	Work	Checks	Remarks
1	Switch the machine OFF, and disconnect the power plug.		
2	Take out the cartridge, and fold the copy tray and pick-up tray.		Put the cartridge in its storage box, and place it to protect against vibration.
3	Tape the top cover in place.		
4	Place a sheet of A4/LTR paper on the copyboard, and tape the copyboard in place.		

CHAPTER 9

MAINTENANCE AND SERVICING

This chapter outlines the machine's maintenance parts and how to make various checks.

I. PERIODICALLY REPLACED PARTS	9-1	IV. NOTES ABOUT CARTRIDGE	9-2
II. DURABLES.....	9-1	A. Storing Sealed Cartridges.....	9-2
III. PERIODICAL SERVICING	9-1	B. Storing and Handling Unsealed Cartridges	9-3

Blank Page

I. PERIODICALLY REPLACED PARTS

The machine does not have parts which must be replaced on a periodical basis.

II. DURABLES

The machine does not have parts which are classified as durables.

III. PERIODICAL SERVICING

The machine does not have parts that require periodical servicing.

IV. NOTES ABOUT CARTRIDGE

The cartridge is affected by the environment, regardless of whether it is sealed or unsealed and installed in the machine or otherwise. Although the properties of the cartridge change over time independent of how many copies have been made, the degree of care taken for the cartridge affects how long it may remain stable.

A. Storing Sealed Cartridges

When storing the cartridge in a warehouse or workshop, make sure the place is controlled to the specifications shown in Table 9-401A.

- a. Avoid direct rays of the sun.
- b. Avoid areas subjected to appreciable vibration.
- c. Do not drop or subject it to impact.

Temperature	Normal (9/10 of period)		0° to 35°C/ 32° to 95°F
	Severe (1/10 of period)	High	35° to 40°C/ 95° to 104°F
		Low	-20° to 0°C/ -4° to 32°F
Temperature fluctuations (within about 3 min)			40° → 15°C/ 104° → 59°F -20°C → 25°C/ -4°F → 77°F
Humidity	Normal (9/10 of period)		35 to 85%RH
	Severe (1/10 of period)	High	85 to 95%RH
		Low	10 to 35%RH
Atmospheric pressure			460 to 760 mmHg (0.1 to 1 atm)

Table 9-401A Temperature/Humidity Specifications

Temperature	Humidity
-20° to 40°C/-4° to 104°F	90% or less

Table 9-402A Transportation

B. Storing and Handling Unsealed Cartridges

The photosensitive medium is an organic photoconductor (OPC), which is extremely susceptible to light. Since the cartridge also contains toner, you must be extra careful when storing or handling the cartridge. Make sure the user is aware of this fact and will handle the cartridge with care.

1. Storing Unsealed Cartridges

- a. Avoid areas subjected to strong rays of the sun. Do not keep it in a car even in a protective box; the inside may become extremely hot.
- b. Avoid areas of high or low temperature/ humidity and areas where these factors tend to change rapidly (for example, near air conditioners or heaters).
- c. Avoid areas where dust, ammonium gas, or gases from organic solvents tend to accumulate.
- d. Keep the cartridge in a place 40°C/104°F or less.

2. Handling the Cartridge

- a. When setting the cartridge to the copier or if the toner starts to run short, hold the cartridge horizontally as shown in Figure 9-401B, and rotate it in both directions about 90° to even out the toner inside it. Do not shake the cartridge or hold it in a different way; otherwise, toner may leak out the cartridge.

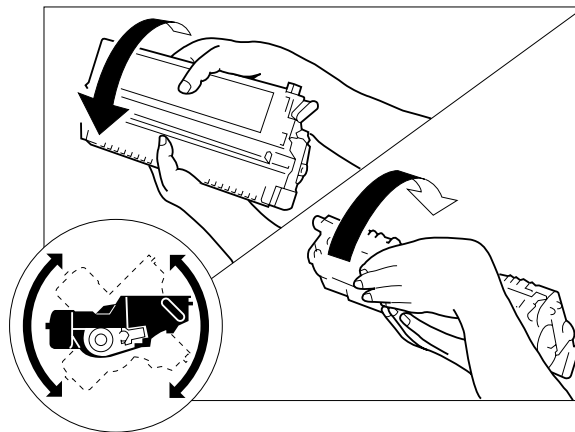

Figure 9-401B

- b. Do not place the cartridge upright or upside down; do not shake it.

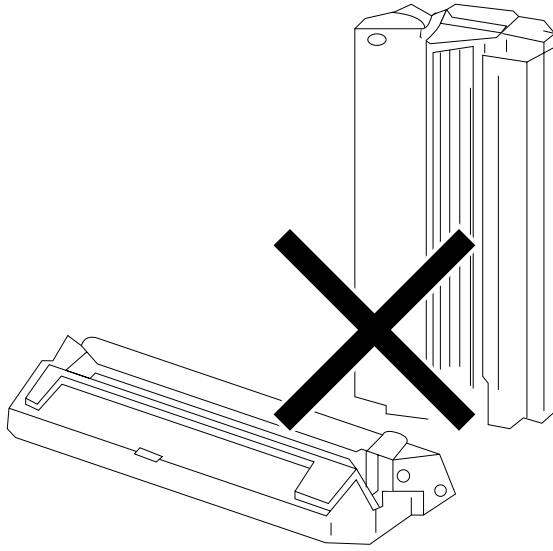

Figure 9-402B

- c. Do not force open the shutter for the photosensitive drum cover found at the bottom of the cartridge; do not touch the surface of the photosensitive drum.

Caution:

If the surface of the photosensitive drum has become soiled, wipe it using a flannel cloth coated with toner. Do not dry wipe it or use solvent.

- d. Do not disassemble the cartridge.
- e. Do not subject the cartridge to vibration or impact; in particular, do not force down the photosensitive drum from above the shutter for the drum cover.
- f. Keep the cartridge out of reach of children.
- g. The photosensitive drum is susceptible to light and, therefore, equipped with a light-blocking shutter; nevertheless, exposure to light for a long time can affect the drum, resulting in copies with white spots or vertical lines. Leave the copier alone for some time for possible recovery; to avoid residual memory, which results in white spots or vertical lines, however, keep the following in mind.

Caution:

Work quickly when removing jams or replacing cartridges.

When the cartridge must be removed for work, be sure to put the cartridge in its storage box or cover it; do not leave it without protective measures once it is outside the copier.

- h. Advise the user to send all used cartridge to the address given and according to the instructions in the User's Guide.

Caution:

Do not subject any used cartridge to fire, or it may burst or explode. If a used cartridge must be dealt with at the site, make sure it is disposed of as incombustible waste.

Reference:

The drum would recover to more or less its normal condition if left alone for five minutes in a dark place after exposure to an intensity of 1500 lux (about 5 minutes under general lighting). However, you must try to avoid any exposure. (The rays of the sun have intensities ranging between about 10000 and 30000 lux.)

CHAPTER 10

TROUBLESHOOTING

This chapter provides tables of maintenance/inspection, standards/adjustments, and identification of problems (image fault/malfunction).

I. MAINTENANCE AND INSPECTION	10-3	A. Troubleshooting Malfunctions	10-24
A. Image Adjustment Basic Procedure	10-3	V. TROUBLESHOOTING PAPER	
B. Points to Note	10-4	FEED PROBLEMS	10-30
II. STANDARDS AND ADJUSTMENTS	10-5	A. Copy Paper Jams	10-30
A. Mechanical	10-5	B. Feeding Faults	10-33
B. Electrical	10-6	VI. FUNCTIONS AND ARRANGEMENT OF ELECTRICAL PARTS	10-34
III. IMAGE TROUBLESHOOTING	10-11	A. Sensors and Solenoids	10-34
A. Making Initial Checks	10-11	B. Switches	10-35
B. Samples of Image Faults	10-16	C. Lamp, Heater, Motor, and Others	10-36
C. Troubleshooting by Image Fault	10-17	D. Printed Circuit Board (PCB)	10-37
IV. TROUBLESHOOTING MALFUNCTIONS	10-24	E. Variable Resistors (VR) and Check Pins by PCB	10-38
		VII. SELF DIAGNOSIS	10-40

Blank Page

■ Guide to the Troubleshooting Table ■

You will find troubleshooting steps organized in tables which are modified versions of general flow charts. Study the following for an idea of how to consult them.

EX.AC power is absent

Cause	Step	Checks	YES/NO	Action
Power plug	1	Is the power plug connected to the power outlet?	NO	Connect the power plug.
Covers	2	Are the front door and the delivery cover closed firmly?	NO	Close the door and the cover.
Power Supply	3	Is the specified voltage present at the power outlet?	NO	The problem is not of the machine. Advise the user.
/	4	Is the specified voltage present between J1-1 and J1-2? (J1 is found near the power cord mount.)	YES	Go to step 6.

- If you want to find out the cause (possible faulty part), see the column under "Cause." In the case of "AC power is absent," the power plug may be disconnected, the covers may not be closed firmly, or the main power supply is absent,
- If you want to find out the action to take or the steps to correct a specific problem, go through the steps in order. Answer YES or NO to the questions under "Checks," and take the action indicated accordingly.

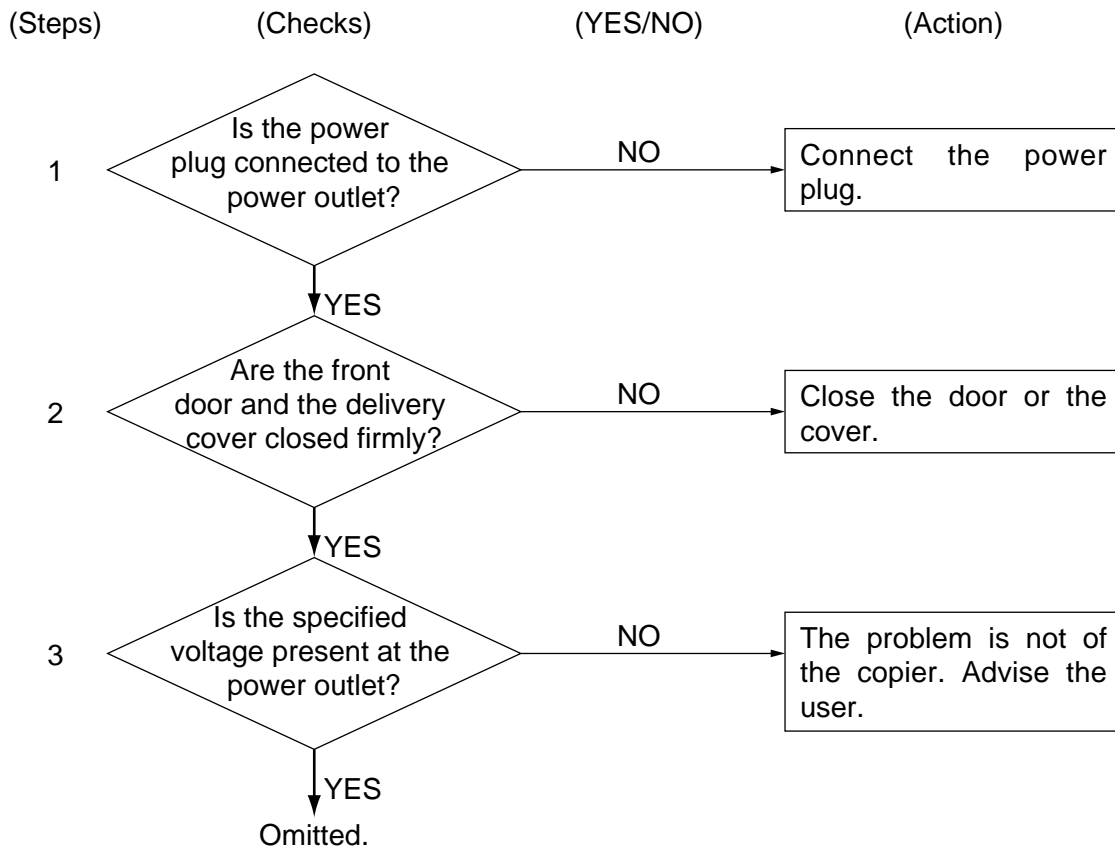

- When checking the voltage using a meter , you may come across such instructions as "Measure the voltage between J109-1 (+) and J109-2 (-) on the DC controller PCB." Connect the positive probe of the meter to the terminal marked (+) and the negative probe to the terminal marked (-).

I. MAINTENANCE AND INSPECTION

A. Image Adjustment Basic Procedure

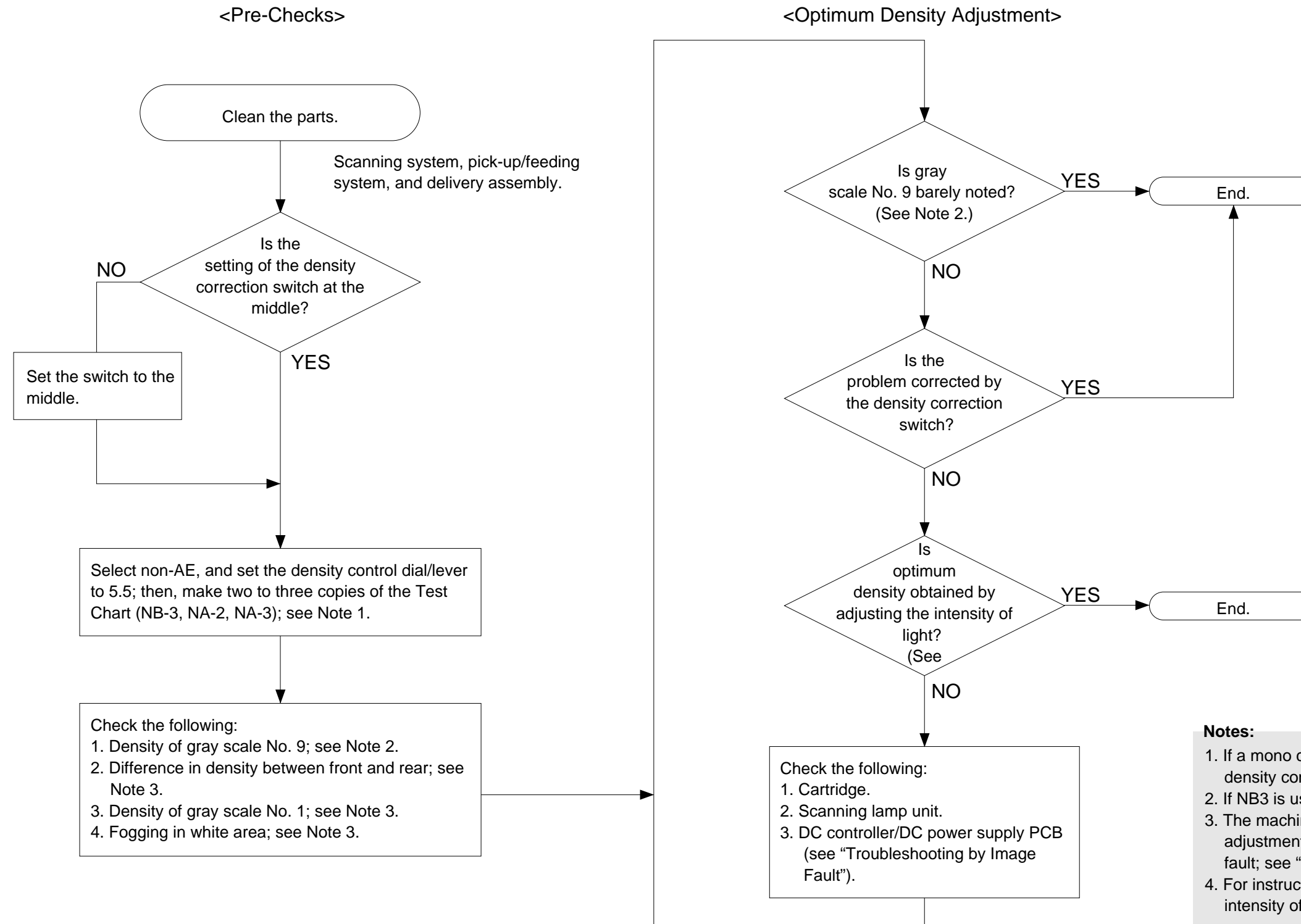

B. Points to Note

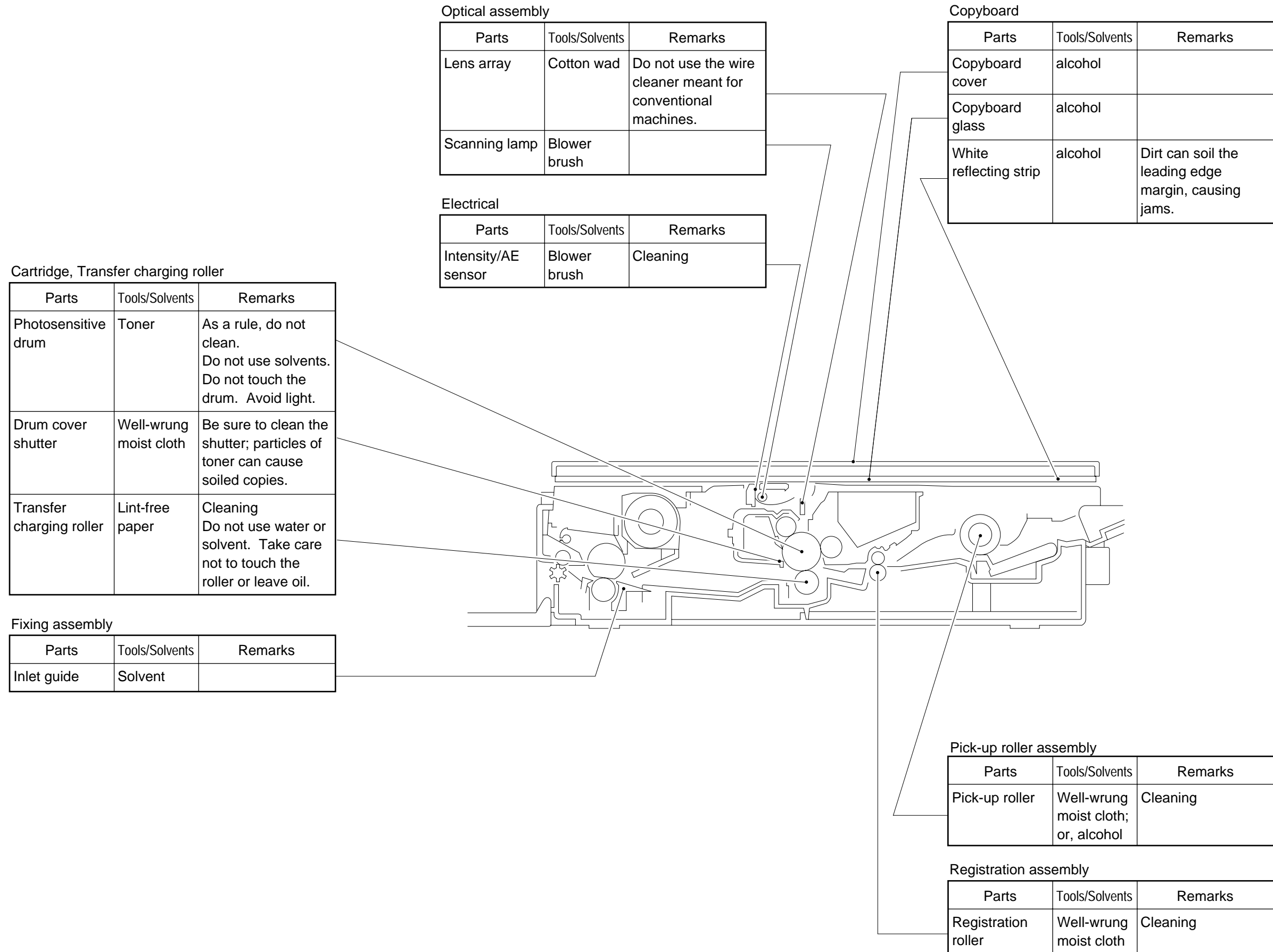

II. STANDARDS AND ADJUSTMENTS

A. Mechanical

1. Image Leading Edge Non-Image Width (position of white paint on back of glass)

The leading edge non-image width must be 2.0 ± 1.0 mm when the Test Sheet is copied.

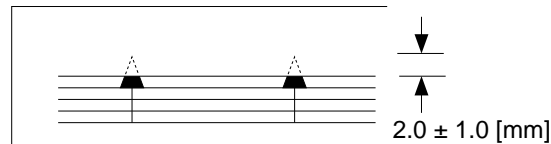

Figure 10-201A

The leading edge non-image width is determined by the position of the white paint found behind the copyboard glass.

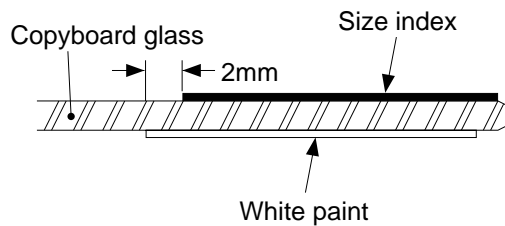

Figure 10-202A

2. Image Leading Edge Margin (point of detection for registration)

The leading edge margin must be 0.2 to 5.0 mm when the Test Sheet is copied. To adjust, move the position of the registration cam.

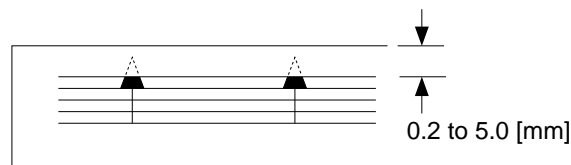

Figure 10-203A

B. Electrical

Notes:

If you have replaced the scanning lamp unit, intensity sensor, AE sensor, or control panel PCB, you must adjust the three variable resistors on the control panel PCB (one, if PC400/FC200); you must, however, adjust them in the order of VR604, VR602, and VR603 (from intensity to AE).

1. Adjusting the Intensity (VR604)

- a. After Replacing the Control Panel PCB Only
 - 1) Disconnect the power plug, and detach the faulty control panel PCB.
 - 2) Set the meter to the '200 k' range, and measure C between the terminal of VR604 and the terminal of R614 on the detached control panel PCB; see Figure 10-201B.
 - 3) Likewise, measure C between the terminal of VR604 and the terminal of R614 on the new control PCB; then, turn VR604 so that the reading is the same as the measurement taken in step 2).
 - 4) In the case of the PC420/430/FC220, adjust VR602 (A between terminals of VR602 and JP607) and VR603 (Between terminals of VR603 and JP621); see Figure 10-201B.
 - 5) Attach the new control panel PCB to the copier.

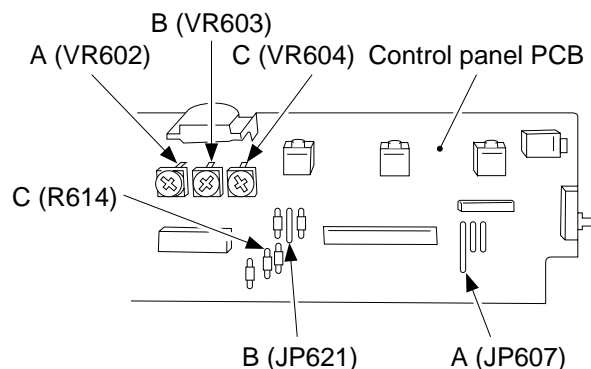

Figure 10-201B (PC420/430/FC220)

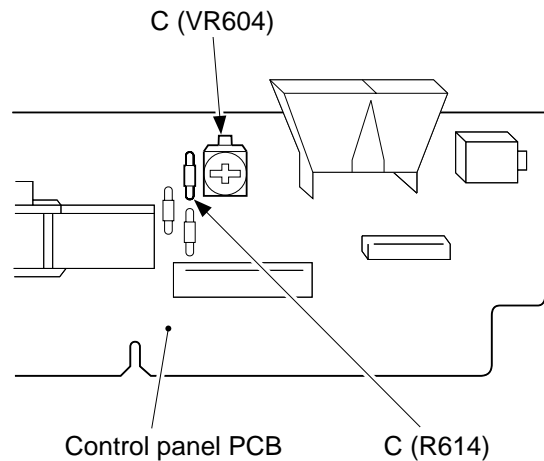

Figure 10-202B (PC400/FC200)

b. After Replacing the Scanning Lamp Unit, Intensity Sensor, or AE Sensor

(Before Adjustment)

- If the scanning lamp has blackened, replace it.
- Clean the scanning system (lens array, lamp reflector, lamp).

- 1) Set the cartridge to the copier.
- 2) De-select AE, and set the copy density control lever/dial to the center.
- 3) Set the density correction switch (SW606) to the center (PC420/430/FC220).
- 4) Set the Test Sheet (NA3/NB3/NA2), and make a copy.
- 5) Check if the copy is free of fogging, and gray scale No. 9 (No. 10, if NB3) is somewhat visible.
 - If too dark,
Turn VR604 on the control panel PCB clockwise slightly to increase the intensity.
 - If too light,
Turn VR604 counterclockwise slightly to decrease the intensity.
- 6) Repeat steps 4) and 5) until the density is optimum.

Notes:

After adjusting the intensity, be sure to adjust the AE mechanism (PC420/430/FC220).

2. Adjusting the AE Mechanism (VR602, VR603)

(Before Adjustment)

- Obtain a newspaper whose text consists of fine print; do not use a section with photos or large characters.
- Make sure you have adjusted light intensity.

- 1) Switch the copier OFF.
- 2) Detach the control panel cover.
- 3) Turn VR602 and VR603 on the control panel PCB fully clockwise.
- 4) Place a newspaper over the AE light-receiving section of the copyboard, and close the copyboard cover.

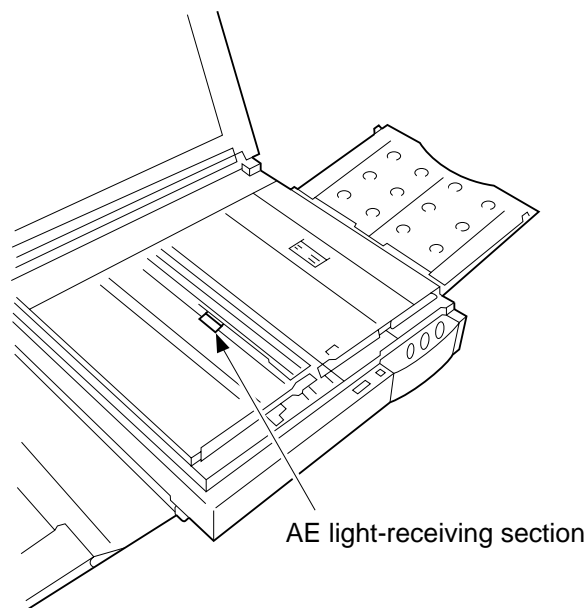

Figure 10-203B

- 5) Short the three jumper wires (JP604, JP605, JP607) on the control panel PCB at the same time using a screwdriver.

Caution:

Take adequate care not to short wires other than those specified.

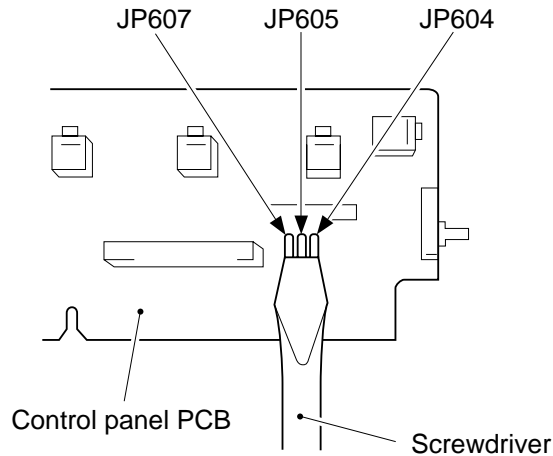

Figure 10-204B

- 6) While keeping the condition in step 5), switch the copier ON.
 - '0' is displayed, the scanning lamp goes ON, and the main motor starts to rotate.
- 7) Stop shorting the jumper wires.
- 8) Set the digital multimeter to the 20V DC range, and turn VR602 (AE offset adjustment) until the voltage between the anode side of the diode (D606; +) and JP607 (GND) is 4.0 ± 0.1 V.

Notes:

You must use a Digital Multimeter when making adjustments in steps 8) and 10).

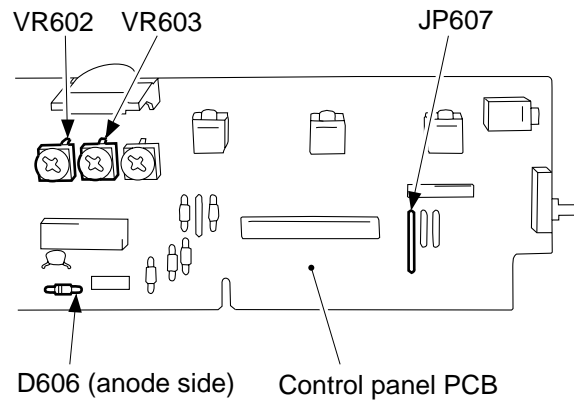

Figure 10-205B

- 9) Place about five sheets of blank copy paper.
- 10) Turn VR603 (AE gain adjustment) until the voltage between the anode side of the diode (D606; it) and JP607 (GND) is 1.8 ± 0.1 V; see Figure 10-205B.
- 11) Switch the copier OFF.

Notes:

Make sure that the jumping wires are no longer shorted.

- 12) Switch the copier ON once again.
- 13) Set the density correction switch (SW606) to the center (of the three settings).
- 14) Make sure that the AE indicator is ON.
- 15) Set the newspaper used in step 4) on the copyboard once again; this time, move the newspaper to a different area.
- 16) Make a copy, and make sure that it is not foggy and has adequate text density.
 - If foggy,
Turn VR602 clockwise slightly.
 - If text density is low,
Turn VR602 counterclockwise slightly.
- 17) Repeat steps 15) and 16) until the density is optimum.

III. IMAGE TROUBLESHOOTING

A. Making Initial Checks

1. Site Environment

- a. The voltage of the power source must be within the specifications.
- b. Avoid areas subjected to dust or high temperature/humidity (near water faucets, water boilers, humidifiers) and areas near open fires.
- c. Avoid areas subjected to ammonium gas.
- d. Avoid direct rays of the sun; otherwise, provide curtains.
- e. Make sure the site is well ventilated.
- f. Make sure the floor is level.

Check the site to see if it meets the above requirements.

2. Checking the Documents

You must first check to see if a particular problem may not be due to the document used.

- a. The copy density reading should be 5.5 ± 1.5 (black)/ 4.5 ± 1.5 (color).
- b. Some backgrounds, i.e., yellow shades, tend to produce copies with poor contrast.
- c. Diazo copies or translucent documents tend to produce copies that may be mistaken for foggy copies.
- d. Documents prepared in light pencil tend to produce copies that may be mistaken for light copies.

3. Checking the Copyboard Cover and Copyboard Glass for Dirt and Scratches

If dirt is found, clean it using mild detergent or alcohol; if scratches are found, replace it.

4. Checking the Lens Array for Dirt

Check the lens array for dirt. If found, clean it using a cotton wad.

5. Checking the Transfer Charging Roller

Check the transfer charging roller for scratches or other abnormalities.

6. Checking the Feeding Assembly

Check the feeding assembly for dirt. If dirt is found, clean it with a moist cloth.

7. Checking the Copy Paper

- a. Check to see if paper of a type recommended by Canon is used.
- b. Check to make sure that the paper is not moist. Try paper fresh out of package.

8. Checking the Durables

Checking the Cartridge

White spots or vertical white lines tend to appear when the cartridge starts to run short of toner; see Figure 10-301A.

Preface

Thank you for purchasing this Canon copier, its functions to ensure safe operation in order to familiarize yourself with its capabilities. After you

purchase this Canon copier, please read this manual carefully to become familiar with its capabilities. After you finish reading this manual

▲ CAUTION:

In this manual, CAUTION indicates a procedure that could result in personal injury or damage to the copier if not followed correctly.

CAUTIONS with this symbol indicate a procedure that could result in personal injury or damage to the copier if not followed correctly.

Figure 10-301A

Go over the following when this is noted.

- 1) Take out the cartridge from the copier, and rotate it several times.

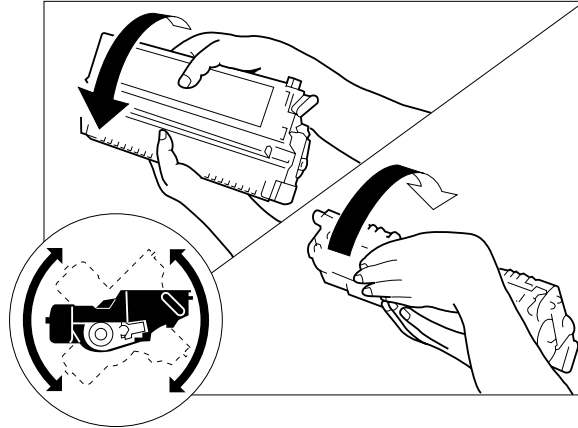

Figure 10-302A

- 2) Set the cartridge back into the copier, and make copies.
 - a. If the copies are normal,
 - The user may use the cartridge for some time more; however, advise the user to procure a replacement cartridge.
 - b. If the copies fail to return to normal,
 - Replace the cartridge as described in “Replacing the Cartridge.”

9. Others

In winter, moving a machine from a cold storage room to a warm site can cause condensation inside the machine, leading to various problems.

- a. Condensation on the scanning system (glass, lens array, reflecting plate) causes dark images.
- b. When too cold, the photosensitive drum assumes a high electrical resistance, resulting in poor contrast.
- c. Condensation in the pick-up/feeding assembly can cause faulty paper transport.
- d. Condensation in the lower roller of the manual pick-up mechanism decreases friction, leading to pick-up failure.
- e. Condensation on the copyboard hinders its smooth movement.

When condensation is noted, dry wipe the parts.

The same holds true of the cartridge. After having moved the cartridge from a cold to warm room, leave it alone for about one to two hours before unpacking it.

B. Samples of Image Faults

not available

C. Troubleshooting by Image Fault

1. The copy is too light (halftone areas only).
2. The copy is too light (dark areas as well).
3. The copy is too light (extremely light overall).

Cause		Step	Checks	YES/NO	Remedies
Lens, Reflecting plate, Intensity sensor		1	Clean the lens, reflecting plate, and intensity sensor. Is the problem corrected?	YES	End.
/		2	Press the Copy Start key, and switch the copier OFF in the middle of operation; then, open the top cover. Is the toner image on the photosensitive drum more or less normal before transfer? (Be sure to check quickly to protect the drum against light.)	NO	Go to step 5.
		Transfer charging roller	3	Is the transfer charging roller normal?	NO
Transfer	Copy paper	4	Try paper fresh out of package. Is the copy density higher?	YES	1. The paper may be moist; advise the user on the correct method of storage. 2. Advise the user that the use of non-recommended paper may not bring about the best results.
Cartridge		5	Replace the cartridge. Is the problem corrected?	YES	End.
DC controller/DC power supply PCB				NO	Replace the DC controller/DC power supply PCB.

4. The copy has uneven density (darker at front).

5. The copy has uneven density (lighter at front).

Cause	Step	Checks	YES/NO	Remedies
Scanner	1	Clean the scanning lamp, reflecting plate, and lens. Is the problem corrected?	YES	End.
Cartridge, Scanning lamp	2	Press the Copy Start key, and switch the copier OFF in the middle of operation; then, open the top cover. Does the toner image on the photosensitive drum before transfer have uneven density?	YES	1. Replace the cartridge. 2. Replace the scanning lamp unit.
Transfer charging roller			NO	Check the transfer charging roller.

6. The copy is foggy (overall).

Cause	Step	Checks	YES/NO	Remedies
Scanner	1	Clean the scanning lamp, reflecting plate, and lens. Is the problem corrected?	YES	End.
Scanning lamp, Developing bias	2	Is continuity present between photosensitive drum PCB and grounding spring?	YES	1. Check if the scanning lamp goes ON normally. 2. Check the developing bias.
Grounding spring			NO	Check to make sure if the grounding spring is properly attached in front of the cartridge.

7. The copy is foggy (paper feed direction).
 8. The copy has dark lines (paper feed direction, relatively narrow).
 9. The copy has dark lines (paper feed direction, thin).

Cause	Step	Checks	YES/NO	Remedies
Scanner	1	Clean the scanning lamp, reflecting plate, and lens. Is the problem corrected?	YES	End.
Cartridge	2	Take out the cartridge, and put it back in. Is the problem corrected?	YES	End.
			NO	Replace the cartridge.

10. The copy has white spots (paper feed direction).
 11. The copy has white lines (paper feed direction).

Cause	Step	Checks	YES/NO	Remedies
Fixing assembly	1	Press the Copy Start key, and switch the copier OFF in the middle of operation; then, open the top cover. Does the copy image have white spots or white lines before fixing?	NO	Check the fixing assembly.
Cartridge	2	Rotate the cartridge several times. Is the problem corrected?	YES	Advise the user that the cartridge is running short of toner.
Transfer charging roller	3	Is there foreign matter or scratches on the transfer charging roller?	YES	Remove the foreign matter, or replace the transfer charging roller.
Cartridge			NO	Replace the cartridge.

12. The copy has white spots (cross feed direction).

Cause	Step	Checks	YES/NO	Remedies
Copy paper	1	Is the copy paper of a type recommended by Canon?	NO	Try recommended paper; if the results are good, advise the user to use recommended paper.
	2	Try copy paper fresh out of package. Is the problem corrected?	YES	The copy paper may be moist; advise the user to store it wrapped.
Copyboard rail	3	Is the problem noted at the same position on all copies?	YES	Check the copyboard rail for foreign matter.
Scanning lamp, Developing bias			NO	Check the scanning lamp for flickering, and check the presence/absence of a developing bias.

13. The back of the copy is soiled.

Cause	Step	Checks	YES/NO	Remedies
	1	Press the Copy Start key, and switch the copier OFF while the copy paper is moving through the feeding assembly. Is the back of the copy soiled?	NO	Go to step 3.
Transfer charging assembly	2	Is the transfer charging assembly soiled?	YES	1. Clean the transfer charging assembly. 2. Clean the registration roller. 3. Clean the pick-up guide plate. 4. Check the cartridge for leakage of toner.
Feeding assembly	3	Is the feeding assembly soiled?	YES	Clean the feeding assembly.
Delivery roller			NO	Clean the delivery roller.

14. The copy has faulty fixing.

Cause	Step	Checks	YES/NO	Remedies
Copy paper	1	Is the copy paper of a type recommended by Canon?	NO	Try paper of a recommended type; if the results are good, advise the user to use recommended paper.
Fixing film	2	Is the faulty fixing vertical and in the form of lines?	YES	Check the fixing film and pressure roller for scratches. If scratches are found, replace the fixing unit or roller.
DC controller/DC power supply PCB	3	Is the heater turned ON for control after copy operation is started?	YES	The control temperature for the fixing heater may be low; check the thermistor and DC controller/DC power supply PCB.
Fixing heater			NO	See "The fixing heater fails to operate."

15. The copy has faulty leading edge registration (blank area much too wide).**16. The copy has faulty leading edge registration (blank area too wide).****17. The copy has faulty leading edge registration (no blank area).**

Cause	Step	Checks	YES/NO	Remedies
Registration cam	1	Move the registration cam on the copyboard left and right. Is there any change to the registration?	YES	Adjust the position of the registration cam.
Solenoid (SL1), DC controller/DC power supply PCB	2	Is the solenoid for registration (SL1) operating normally?	NO	1. Check the solenoid (SL1). 2. Check the DC controller/DC power supply PCB.
Pick-up roller	3	Is the copy paper of a type recommended by Canon?	YES	Check the pick-up roller.
Copy paper			NO	Try copy paper of a type recommended by Canon; if the results are good, advise the user to use recommended paper.

18. The copy has a blurred image.

Cause	Step	Checks	YES/NO	Remedies
Copyboard rail	1	Is the movement of the copyboard rail smooth?	NO	Replace the copyboard rail.
Copyboard drive assembly	2	Is the movement of the copyboard normal?	NO	Check the copyboard drive assembly; if a fault is found, replace the part.
Main motor assembly	3	Is the main motor assembly normal?	NO	Replace the main motor assembly.
Feeding assembly	4	Does the copy paper stop or jump near the transfer assembly?	YES	Remove the foreign matter or burrs from the feeding system.
Cartridge			NO	Replace the cartridge.

19. The copy is foggy (cross feed direction).

Cause	Step	Checks	YES/NO	Remedies
Scanning lamp	1	Does the scanning lamp flicker?	YES	Replace the scanning lamp unit.
Cartridge	2	Replace the cartridge. Is the problem corrected?	YES	End.
High-voltage transformer			NO	Check the high-voltage transformer (DC controller/DC power supply PCB).

20. The copy has poor sharpness (focus).

Cause	Step	Checks	YES/NO	Remedies
	1	Does the copy have an image which is too light at the same time?	YES	Correct the light image first.
Document	2	Is there a gap between the document and the copyboard glass?	YES	<ul style="list-style-type: none"> • Check the copyboard glass to make sure it is not warped. • Advise the user how to place documents correctly.
Lens	3	Is the lens off contact?	YES	Push the lens into place while taking great care not to scratch it.
Scanner	4	Clean the scanning lamp, reflecting plate, and lens. Is the problem corrected?	YES	End.
Cartridge			NO	Replace the cartridge.

21. The copy is blank.

Cause	Step	Checks	YES/NO	Remedies
Cartridge	1	Is the cartridge set in the copier?	NO	Set the cartridge in the copier.
	2	Does the cartridge have toner?	NO	Replace the cartridge.
	3	Has the seal been removed from the cartridge?	NO	Remove the seal.
	4	Set the cartridge in the copier, and close the copier. Does the drum cover shutter open without fail?	NO	Make adjustments so that the shutter opens smoothly.
Drum drive assembly	5	Is the drum drive gear rotating normally?	NO	Check the drum drive assembly.
High-voltage transformer	6	Are the primary charging terminal at the front left of the cartridge and the high-voltage terminal at the bottom of the copier in firm contact?	YES	Check the high-voltage transformer (DC controller/DC power supply PCB).
Terminals for primary charging, Cartridge			NO	1. Check the contact for electrical continuity. 2. Try replacing the cartridge.

22. The copy is solid black.

Cause	Step	Checks	YES/NO	Remedies
/	1	Is the scanning lamp ON during copying operation?	YES	Check if the cartridge is set properly.
			NO	See "The scanning lamp fails to go ON."

IV. TROUBLESHOOTING MALFUNCTIONS

A. Troubleshooting Malfunctions

1. ⌘ (self diagnosis; PC400/FC200)

Cause	Step	Checks	YES/NO	Remedies
/	1	Switch the copier ON. Does the Jam indicator remain On for about 0.5 sec, and does the copier go OFF automatically thereafter?	YES	See 'E00'.
			NO	See the discussions on 'E2', 'E6', and 'E9'.

2. E0

Cause	Step	Checks	YES/NO	Remedies
Thermistor (TH1)	1	Set the meter to the '12VDC' range, and wait until the fixing heater is sufficiently cool. Measure the voltage between J603-1 (+) and J603-2 (-). Is it about 3.2 V or more?	NO	Check the wiring from the DC controller/DC power supply PCB to the thermistor (TH1); if normal, replace the fixing assembly.
/	2	Does the fixing heater operate normally?	NO	See "The fixing heater fails to operate."
DC controller/DC power supply PCB	3	Switch the copier ON, and make a copy. Measure the voltage between J603-1 and J603-2 once again. Is the voltage lower than that measured in step 1?	YES	Replace the DC controller/DC power supply PCB.
Fixing assembly			NO	Check the wiring from the DC controller/DC power supply PCB to the thermistor (TH1); if normal, replace the fixing assembly.

3. E2

Cause	Step	Checks	YES/NO	Remedies
Copyboard	1	Does the copying operation start with the copyboard at the left or right?	YES	Check the operation with the copyboard moved to the center; advise the user that this is not the copier's problem
	2	Does the copyboard move in reverse? In addition, does it move in reverse far too slowly?	NO	See "The copyboard fails to move."
DC controller/DC power supply PCB	3	Does the copyboard move in reverse after copying operation has started and move forward after it has reached the copyboard start position?	YES	Replace the DC controller/DC power supply PCB.
Copyboard drive assembly, Copyboard glass assembly			NO	1. Check the copyboard position sensor (Q902). 2. Try replacing the copyboard drive assembly. 3. Check the start position cam and reversal cam in the copyboard glass assembly.

4. E6

Cause	Step	Checks	YES/NO	Remedies
Control panel PCB	1	Replace the control panel PCB. Is the problem corrected?	YES	End.
DC controller/DC power supply PCB			NO	Check the harness from the control panel PCB to the DC controller/DC power supply PCB; if normal, replace/DC power supply PCB.

5. E9

Cause	Step	Checks	YES/NO	Remedies
DC controller/ DC power supply PCB	1	Replace the DC controller/DC power supply PCB. Is the problem corrected?	YES	End.
Power supply			NO	Advise the user that the frequency of the power supply is faulty.

6. AC power is absent.

Cause	Step	Checks	YES/NO	Remedies
Power plug	1	Is the power plug connected to the copier and the power outlet?	NO	Connect the power plug.
	2	Is 'E' code (PC420/430/FC220) or 'JAM' (PC400/FC200) indicated for about 0.5 sec after the power switch is turned ON and does the power turn OFF thereafter?	YES	See 'E0'.
Top cover, Delivery assembly cover	3	Are the top cover and delivery assembly cover closed properly?	NO	Close the top cover and delivery assembly cover.
Power supply voltage	4	Is the rated voltage present at the power outlet?	NO	Advise the user that the problem is not of the copier.
Door switch	5	Is the door switch (SW1,SW2) normal?	NO	Replace the door switch.
DC controller/ DC power supply PCB	6	Is the rated power supply voltage present between J103 and J104 on the DC controller/DC power supply PCB? (Set the meter to the 300V AC range).	YES	Replace the DC controller/ DC power supply PCB.
Fixing assembly	7	Replace the fixing assembly. Is the problem corrected? (fixing heater error temperature detection circuit ON)	YES	End.
			NO	Replace the DC controller/ DC power supply PCB.

7. Pick-up fails.

Cause	Step	Checks	YES/NO	Remedies
	1	Move the copyboard to the left until it stops, and open the top cover. Does the pick-up roller rotate when the door switch is turned ON and the Copy Start key is pressed at the correct pick-up timing?	YES	See "Pick-Up Assembly" in "Troubleshooting Feeding Faults."
Main motor (M1)	2	Is the main motor rotating?	NO	See "The main motor fails to rotate."
Pick-up sensor (Q131)	3	Does the copier operate normally when the pick-up sensor (Q131) is blocked with paper?	YES	Check the sensor lever.
Pick-up solenoid (SL1; PC420/430/FC220), Registration solenoid (SL1; PC400/FC200)	4	Set the meter to the '30VDC' range. Does the voltage between J201-6 (+) and J201-7 (-) on the DC controller/DC power supply PCB change to about 24 V at pick-up timing?	YES	Check the spring clutch in the registration assembly and pick-up assembly; if normal, replace the solenoid.
DC controller/ DC power supply PCB			NO	Check the wiring from the solenoid to the DC controller/DC power supply PCB; if normal, replace the DC controller/DC power supply PCB.

8. The scanning lamp fails to go ON.

Cause	Step	Checks	YES/NO	Remedies
Scanning lamp (LA1-LA8)	1	Is the scanning lamp unit attached correctly?	NO	Re-attach the lamp unit.
Scanning lamp (LA1-LA8)	2	Is the scanning lamp black?	YES	Replace the scanning lamp unit.
DC controller/DC power supply PCB	3	Is the connector of the scanning lamp connected firmly?	YES	Replace the DC controller/DC power supply PCB.
Connector			NO	Re-connect the connector.

9. The main motor fails to rotate.

Cause	Step	Checks	YES/NO	Remedies
Main motor (M1)	1	Set the meter to the '30VDC' range. Does the voltage between J903-1 (+) and J903-2 change from about 0 V to about 20 V according to the operation of the main motor?	YES	Replace the main motor.
DC controller/DC power supply PCB			NO	Check the wiring from the motor to the DC controller/DC power supply PCB; if normal, replace the DC controller/DC power supply PCB.

10. The copyboard fails to move.

Cause	Step	Checks	YES/NO	Remedies
Main motor (M1)	1	Is the main motor rotating?	NO	See "The main motor fails to rotate."
Copyboard, Copyboard drive assembly	2	Push the copyboard by hand. Does it move smoothly?	NO	Check the copyboard and copyboard drive assembly.
DC controller/DC power supply PCB	3	Set the meter to the '200 Ω' range. Disconnect J902 from the copyboard drive solenoid, and measure the resistance between terminals of SL2. Is it about 120 Ω?	YES	Check the wiring from the solenoid to the DC controller/DC power supply PCB; if normal, replace the DC controller/DC power supply PCB.
Copyboard drive solenoid (SL2)			NO	Check the solenoid (SL2).

11. ⚡ (paper feeding normally)

Cause	Step	Checks	YES/NO	Remedies
Copy paper	1	Are there pieces of copy paper in the delivery assembly or pick-up assembly?	YES	Remove the pieces of paper.
Sensor lever	2	Is the movement of the delivery sensor and pick-up sensor levers smooth?	NO	Correct the movement.
Delivery sensor PCB (Q801)	3	Replace the delivery sensor PCB. Does the copier operate normally?	YES	End.
DC controller/DC power supply PCB			NO	Check the wiring from the control panel PCB to the DC controller/DC power supply PCB; if normal, replace the DC controller/DC power supply PCB.

12. ⚡ (at time of jam)

Cause	Step	Checks	YES/NO	Remedies
Control panel PCB	1	Replace the control panel PCB. Does the indicator go ON?	YES	End.
DC controller/DC power supply PCB			NO	Replace the DC controller/DC power supply PCB.

13. The fixing heater fails to operate.

Cause	Step	Checks	YES/NO	Remedies		
Heater (H1), Thermal fuse (FU2)	1	Is continuity present between terminals of the heater?	NO	Replace the fixing assembly.		
Thermistor (TH1, TH2)	2	Is the resistance between the following terminals on the control panel PCB 0 Ω or about 1.3 M Ω? <table border="1" style="margin-left: auto; margin-right: auto;"> <tr> <td>TH1</td> <td>J603-1 ↔ J603-2</td> </tr> </table>	TH1	J603-1 ↔ J603-2	YES	Replace the fixing assembly.
TH1	J603-1 ↔ J603-2					
Fixing assembly	3	Replace the fixing assembly. Is the problem corrected?	YES	End.		
DC controller/DC power supply PCB			NO	Replace the DC controller/DC power supply PCB.		

V. TROUBLESHOOTING PAPER FEED PROBLEMS

A. Copy Paper Jams

Jams can be classified according to location within the copier:

- ① Pick-up assembly
- ② Separation/feeding assembly
- ③ Fixing/delivery assembly

The discussions that follow are organized with reference to these assemblies.

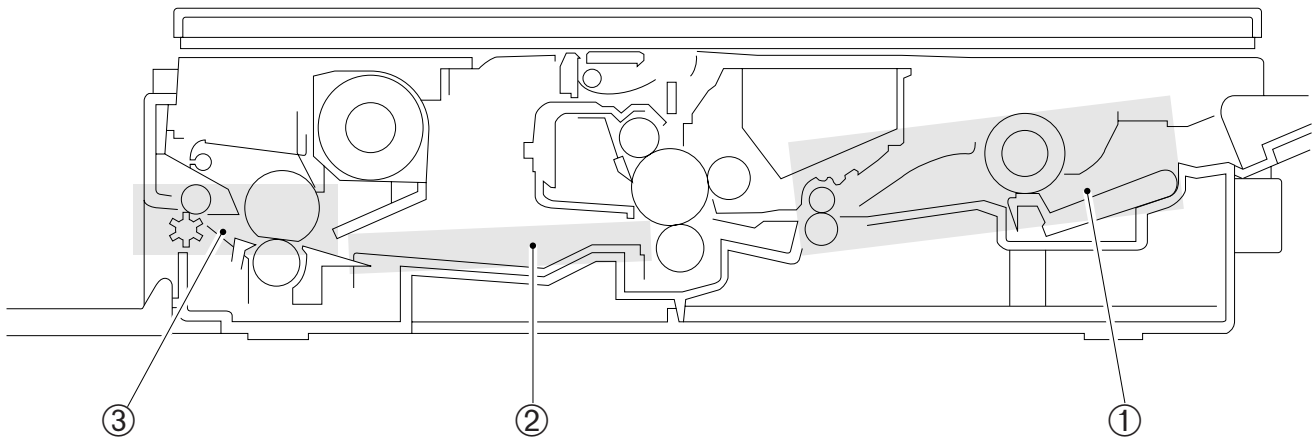

Figure 10-501A

1. Pick-Up Assembly

Cause	Step	Checks	YES/NO	Remedies
Copy paper	1	Try copy paper of a type recommended by Canon. Is the problem corrected?	YES	Advise the user to use recommended paper.
	2	Is the copy paper curled or wavy, or otherwise deformed?	YES	Replace the copy paper; advise the user on the correct method of storage.
Pick-up sensor lever	3	Is the movement of the pick-up sensor lever smooth?	NO	Adjust the movement of the pick-up sensor lever.
Spring (pick-up guide plate; PC420/430/FC220)	4	Check the movement of the pick-up guide plate found under the pick-up roller. Is its movement smooth?	NO	Check the position of the spring of the pick-up guide plate.
Pick-up roller	5	Is the pick-up roller deformed or worn?	YES	Replace the pick-up roller.
Spring (for pick-up control), Spring clutch (PC420/430/FC220)			NO	1. Check the spring. 2. Check the spring clutch.

2. Separation/Feeding Assembly

Cause	Step	Checks	YES/NO	Remedies
Copy paper	1	Try paper of a type recommended by Canon. Is the problem corrected?	YES	Advise the user to use recommended paper.
	2	Is the copy paper curled or wavy, or otherwise deformed?	YES	Replace the copy paper; advise the user on the correct method of storage.
Feeding assembly	3	Is foreign matter found in the feeding assembly?	YES	Remove the foreign matter.
Static eliminator	4	Is the static eliminator soiled with toner?	YES	Clean the static eliminator.
Registration roller	5	Is the registration roller worn, deformed, or soiled?	YES	If dirt is found, clean it using alcohol; if worn or deformed, replace it.
Spring (for registration control), Spring clutch (registration assembly)			NO	1. Check the spring. 2. Check the spring clutch in the registration assembly.

3. Fixing/Delivery Assembly

Cause	Step	Checks	YES/NO	Remedies
Separation/Feeding assembly	1	Are the copy image and the document matched correctly?	NO	Check the separation/feeding assembly.
Fixing assembly inlet guide	2	Is the inlet guide soiled with foreign matter or toner?	YES	Clean it.
Delivery sensor lever	3	Does the delivery sensor lever move smoothly?	NO	Correct it so that the lever moves smoothly.
Delivery roller assembly	4	Is the delivery sensor (Q801) PCB normal?	YES	Check the delivery roller assembly.
Delivery sensor PCB			NO	Replace the delivery sensor PCB.

B. Feeding Faults

1. Double Feeding

Cause	Step	Checks	YES/NO	Remedies
Copy paper	1	Try copy paper of a type recommended by Canon.	YES	Advise the user to use recommended paper.
Separation pad	2	Check the movement of the pick-up guide plate. Is the movement smooth?	YES	Check the condition of the separation pad.
Spring (pick-up guide plate; PC420/430/FC220)			NO	Check the position of spring.

2. Wrinkles

Cause	Step	Checks	YES/NO	Remedies
Pick-up assembly, Registration roller	1	Switch the copier OFF while the copy paper is moving through the feeding assembly. Is the paper wrinkled at the time? Or, is it moving askew?	YES	Check the pick-up assembly. Check the registration roller.
Copy paper	2	Try paper fresh out of package. Is the problem corrected?	YES	The paper may be moist; advise the user on the correct method of storage. Also, advise the user to remove curling before feeding paper for a second time when making two-sided/overlay copies.
	3	Try copy paper of a type recommended by Canon.	YES	Advise the user to use recommended paper.
Fixing assembly	4	Is the inlet guide soiled with foreign matter or toner?	YES	Clean it using solvent.
			NO	Check the fixing assembly.

VI. ARRANGEMENT AND FUNCTIONS OF ELECTRICAL PARTS

A. Sensors and Solenoids

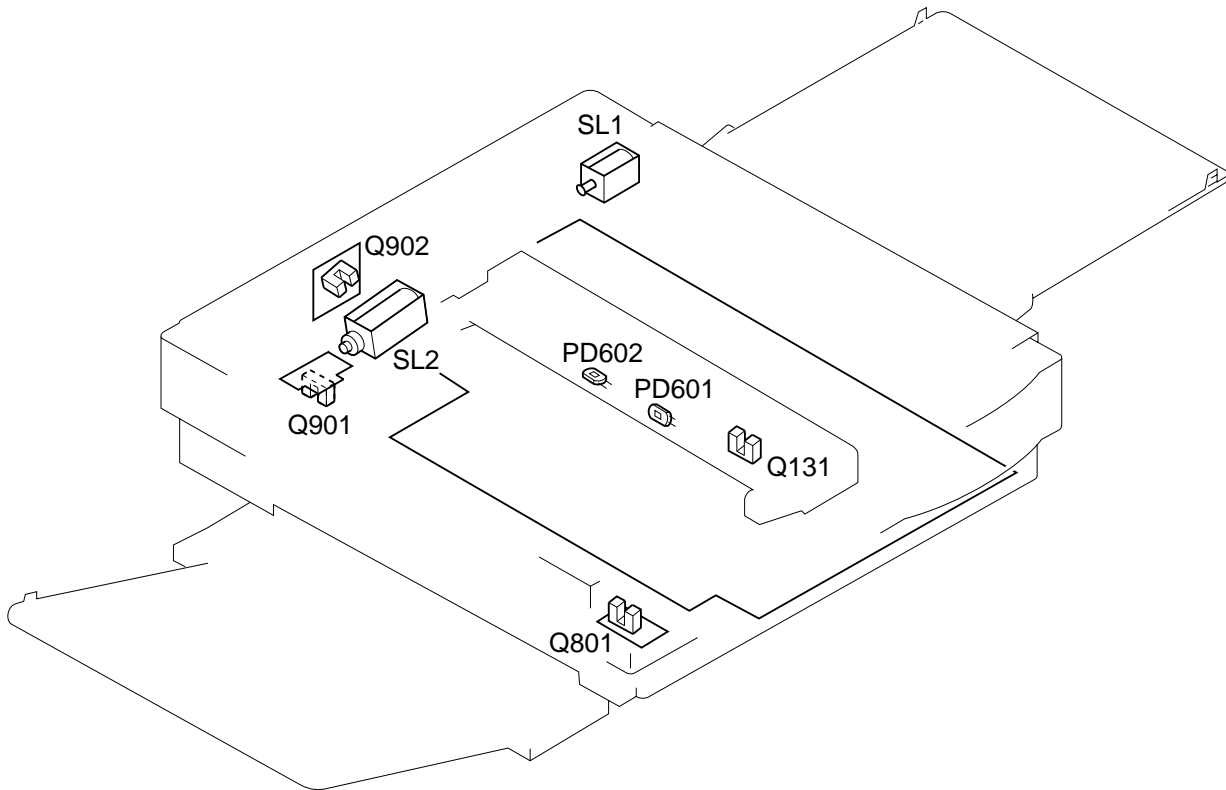

Figure 10-601A

Symbol	Name	Notation	Description
	Photointerrupter	Q131 Q801 Q901 Q902	Pick-up assembly paper sensor Delivery assembly paper sensor Motor rotation sensor Copyboard position sensor
	Photodiode	PD601 PD602	Intensity sensor AE sensor
	Solenoid	SL1 SL2	Pick-up/registration solenoid Copyboard drive solenoid

B. Switches

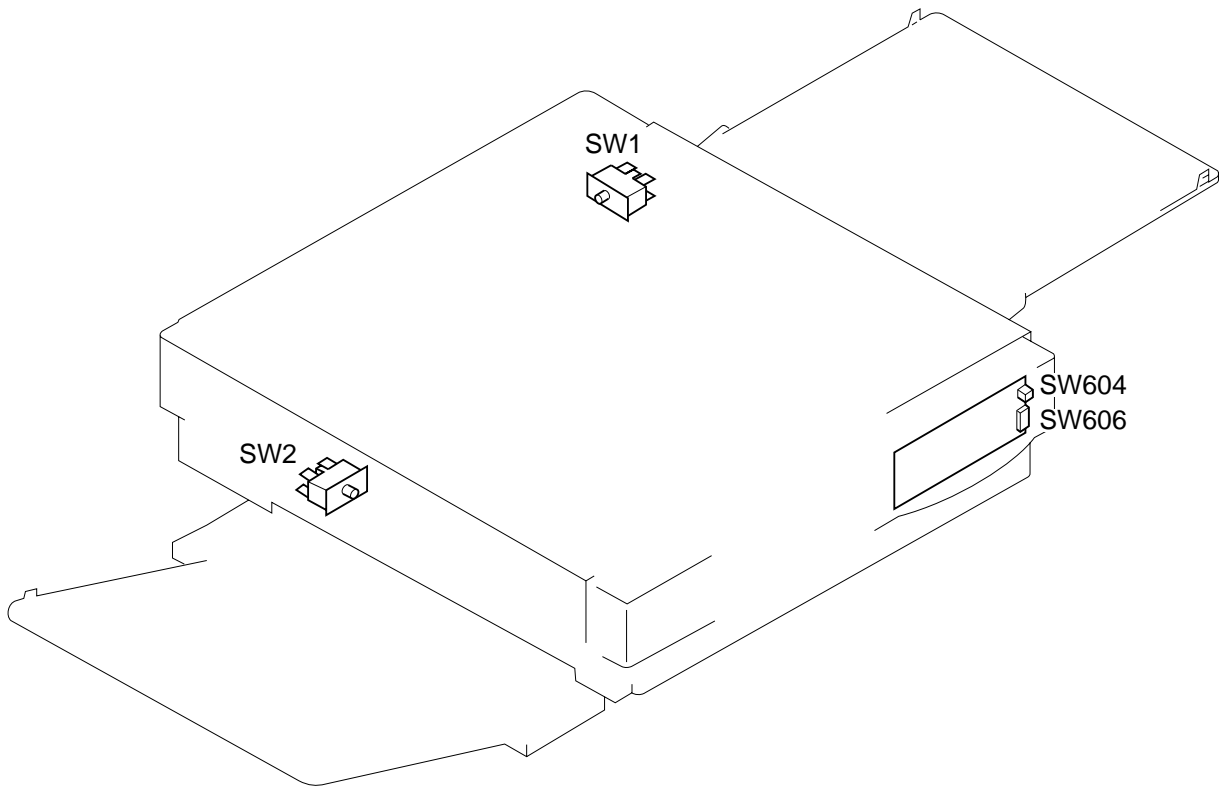



Figure 10-601B

Symbol	Name	Notation	Description
	Switch	SW1 SW2	Top cover switch Delivery assembly door switch
	Switch	SW604 SW606	Power switch Density 3-setting switch

C. Lamp, Heater, Motor, and Others

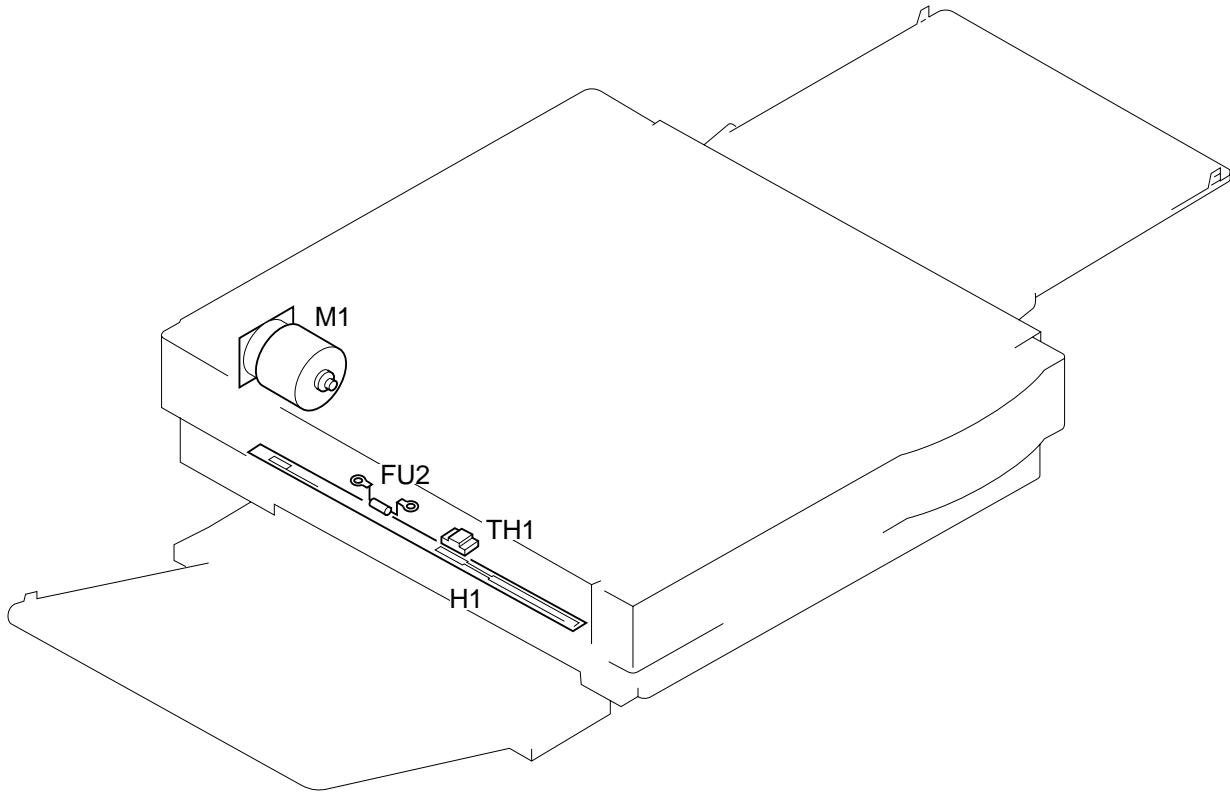
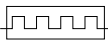





Figure 10-601C

Symbol	Name	Notation	Description
	Heater	H1	Fixing heater
	Motor	M1	Main motor
	Thermistor	TH1	Fixing heater temperature detection
	Thermal fuse	FU2	Fixing heater overheating detection

D. Printed Circuit Board (PCB)

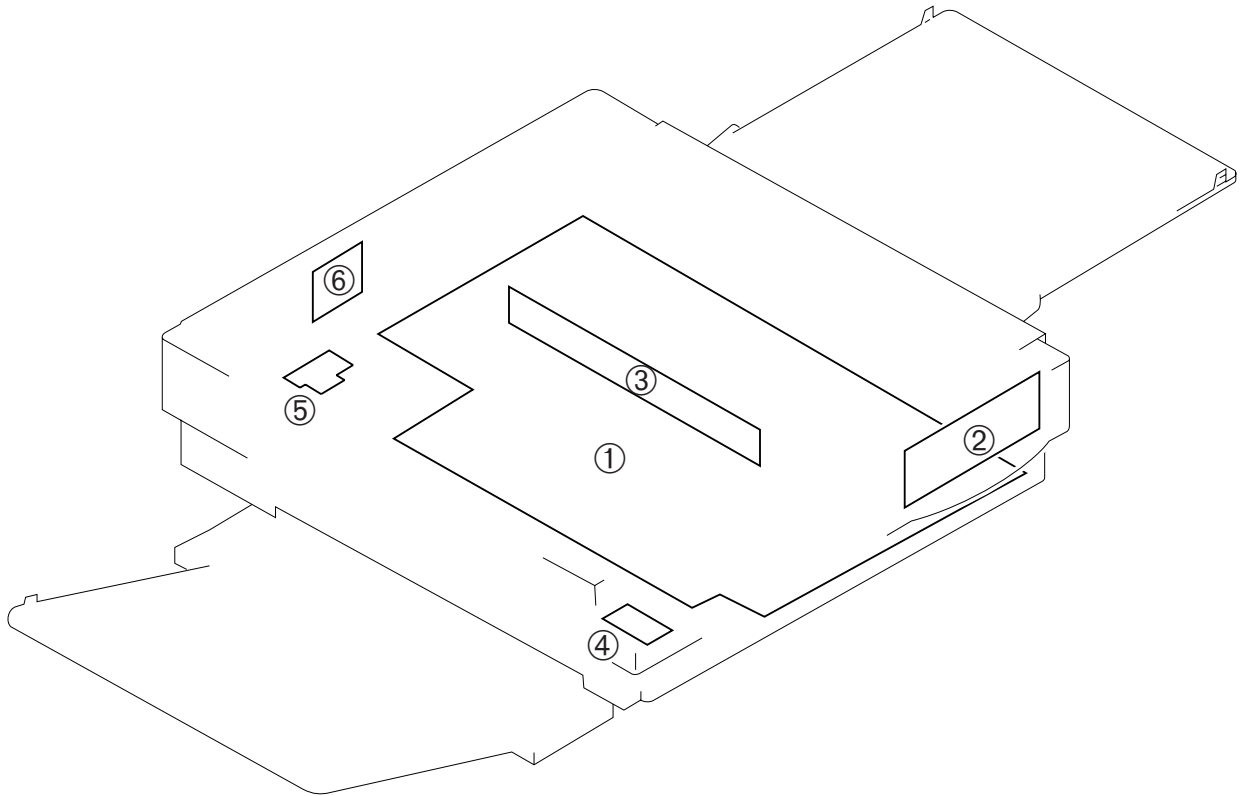

Figure 10-601D



Ref.	Name	Description
①	DC controller/DC power supply PCB	Controls sequence, supplies DC power, controls scanning lamp ON
②	Control panel PCB	Controls/displays copying operation
③	Scanning lamp PCB	Scanning lamp (LA1-LA8)
④	Delivery sensor PCB	Detects delivery
⑤	Motor rotation sensor PCB	Detects main motor rotation
⑥	Copyboard position sensor PCB	Detects copyboard position

E. Variable Resistors (VR) and Check Pins by PCB

Of the variable resistors (VR) and check pins used in the copier, those used in the field are discussed herein.

Do not touch those VRs and check pins not discussed herein; they are for factory use only and require special tools and high precision for adjustment.

Note:

- 1. VRs that may be used in the field. 
- 2. VRs that must not be used in the field. 

1. DC Controller/DC Power Supply PCB

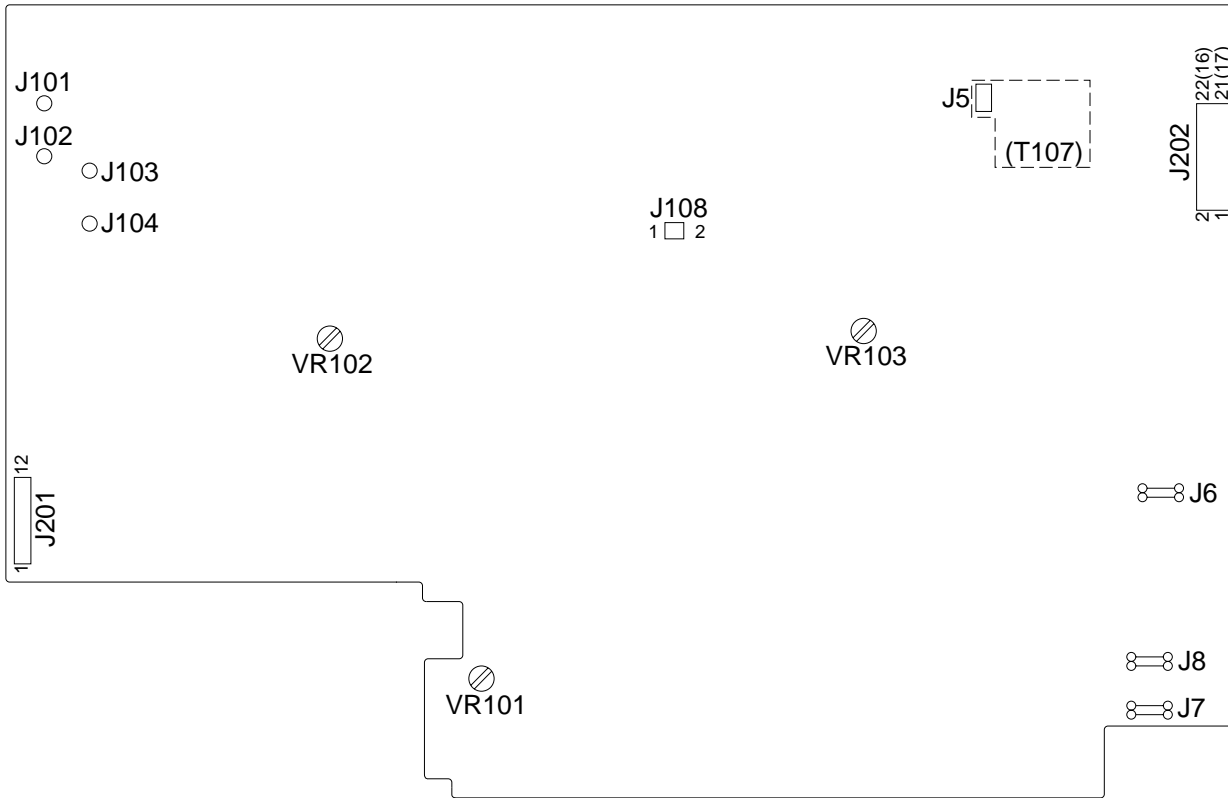

Note: The pin No. in parentheses refers to the PC400/FC200.

Figure 10-601E

2. Control Panel PCB

a. PC420/430/FC220

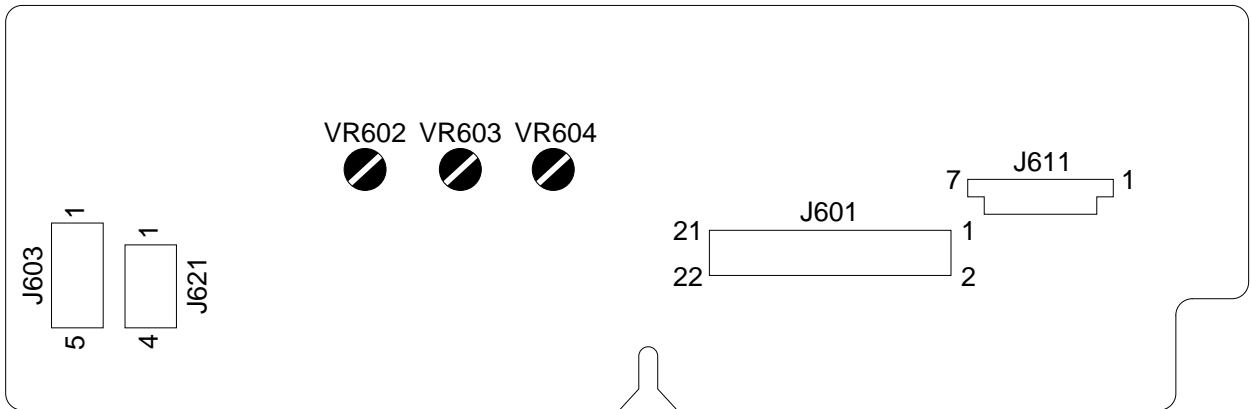

Figure 10-602E

b. PC400/FC200

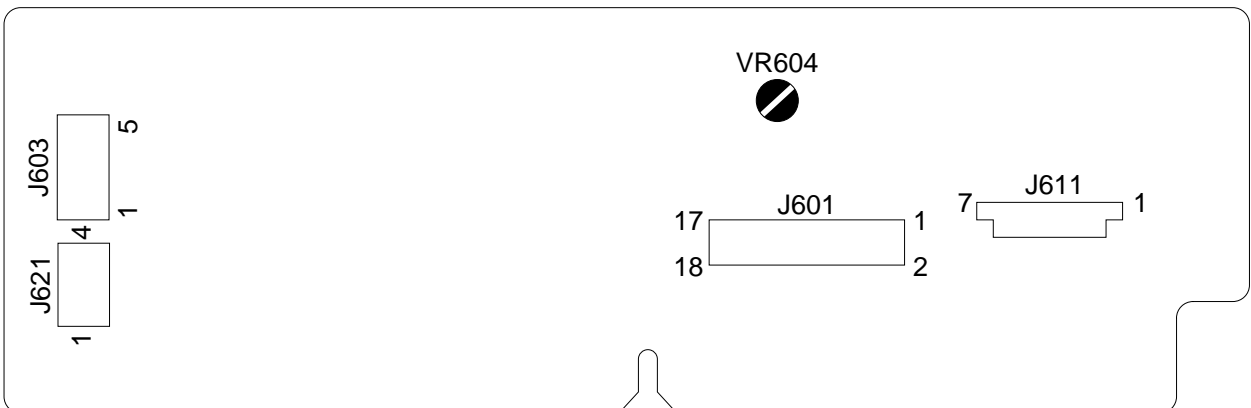

Figure 10-603E

VR	Description
VR602	Use it to adjust the AE offset (use it only after replacing the scanning lamp unit, intensity sensor, AE sensor, or control panel PCB).
VR603	Use it to adjust the AE gain (use it only after replacing the scanning lamp unit, intensity sensor, AE sensor, or control panel PCB).
VR604	Use it to adjust the light intensity (use it only after replacing the scanning lamp unit, intensity sensor, AE sensor, or control panel PCB).

Table 10-601E

VII. SELF DIAGNOSIS

The copier's microprocessor on the DC controller/DC power supply PCB is equipped with a self diagnostic mechanism that checks the condition of the machine; when the mechanism detects an error, it indicates an error code on the copy count display.

(The PC400/FC200 does not have a copy count display; it indicates an error condition by flashing the Jam indicator.)

'E6' is represented by alternating

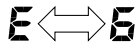

Code	Cause	Description
 (Note)	<ul style="list-style-type: none"> • Thermistor (TH1; faulty) • Fixing heater (H1; faulty) • DC controller/DC power supply (faulty) 	<ul style="list-style-type: none"> • The temperature of the fixing heater is 215°C or more. • The temperature of the fixing heater does not reach 80°C within 2.5 sec. after copying operation has started. • The temperature of the fixing heater lowers below 135°C after it has reached 150°C. • The temperature of the fixing heater does not reach 150°C within 7.5 sec. after copying operation has started. • The maximum supply power is detected for about 5 sec. after the temperature of the fixing heater has reached 150°C.

Note:

If an error associated with 'E0' is detected, 'E' is displayed (PC420/430/FC220) or the Jam indicator (PC400/FC200) remains ON for about 0.5 sec.; thereafter, the power goes out.

Code	Cause	Description
E2	<ul style="list-style-type: none"> • Copyboard drive assembly (faulty operation) • Copyboard drive solenoid (SL2; faulty) • Copyboard position sensor PCB (Q902; faulty) • DC controller/DC power supply PCB (faulty) 	<ul style="list-style-type: none"> • The copyboard position sensor (Q902) goes ON when copying operation starts. • The copyboard position sensor (Q902) is ON 0.8 sec. after copying operation has started. • The copyboard position sensor (Q902) does not go ON within 5.5 sec. after copying operation has started. • The copyboard does not reach the start position within a specific period of time, or it moves past the start position. • The copyboard position sensor (Q902) is ON 1.5 sec. after the copyboard has started moving forward from the start position. • The copyboard position sensor (Q902) does not go ON 10.4 sec. after the copyboard has started moving forward from the start position. • The copyboard position sensor (Q902) does not go ON 1.2 sec. or 4.7 sec. after the copyboard has started moving in reverse from the reversal position.
E5	<ul style="list-style-type: none"> • Control panel PCB (faulty) • DC controller/DC power supply PCB (faulty) 	<ul style="list-style-type: none"> • The scanning lamp has remained for 2 sec. continuously at such times as not prescribed.
E9	<ul style="list-style-type: none"> • Power supply frequency (error) 	<ul style="list-style-type: none"> • The power supply frequency is higher than specified.

Note:

1. The copier does not use code 'E1', 'E3', 'E4', or 'E5'.
2. After self diagnosis has gone ON, the copier may be reset by switching it OFF and then ON.
In the case of 'E0', however, the power is automatically turned OFF. To reset, disconnect the power plug once, open the upper cover, or wait about 5 minutes without any operation; during the period, the microprocessor remains powered and retains 'E0'.
This consideration is to prevent the user from resetting the machine easily when the thermistor may have blown; otherwise, the fixing heater would become overheated, damaging parts near it.
3. Activation of self diagnosis forces the fixing heater (H1) and main motor (M1) OFF.

APPENDIX

A. GENERAL TIMING CHART	A-1	D. SPECIAL TOOLS TABLE	A-7
B. SIGNALS/ABBREVIATIONS LISTA-	3	E. SOLVENTS/OILS TABLE	A-8
C. GENERAL CIRCUIT DIAGRAM...	A-5		

A. GENERAL TIMING CHART

PC400/FC200 General Timing Chart
(A4, 2 copies)

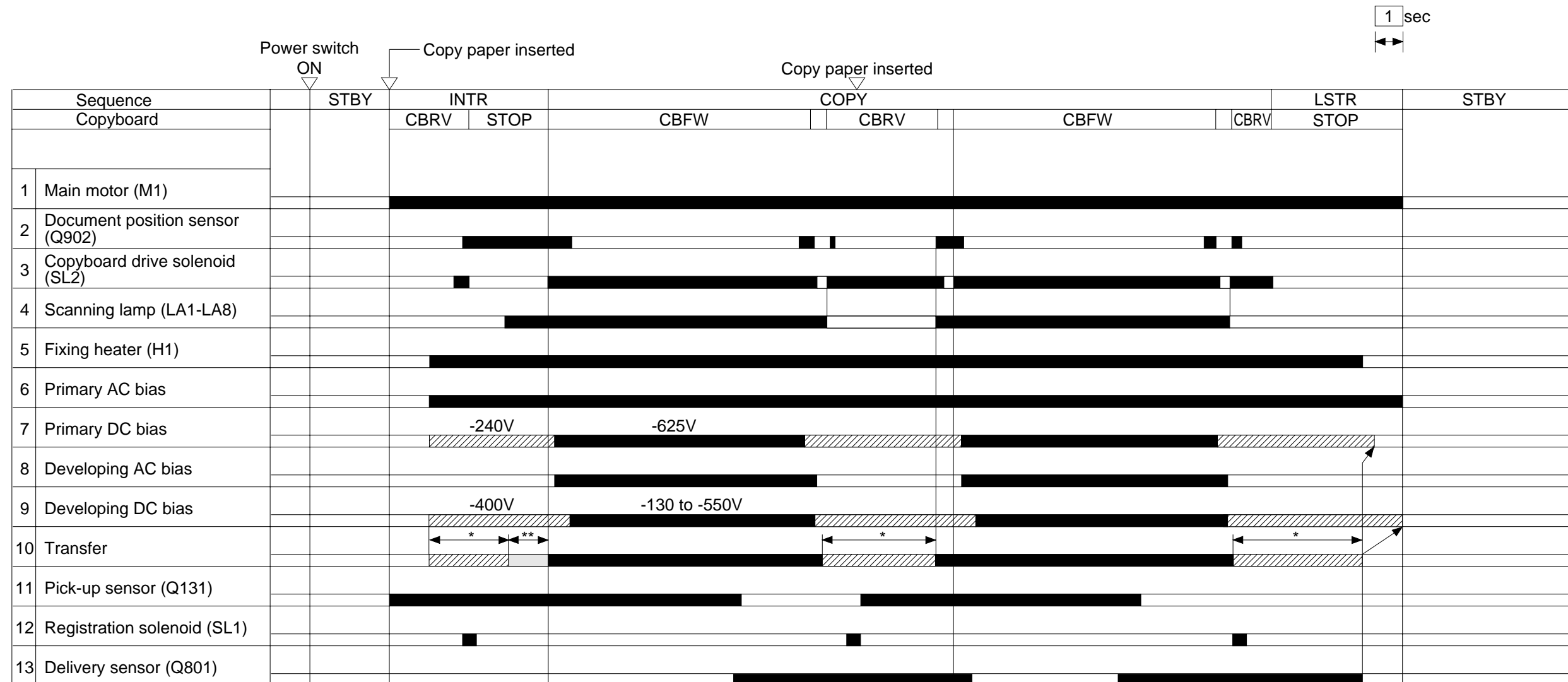

* Cleaning mode.
** Measurement mode.

PC420/430/FC220 General Timing Chart
(A4, 2 copies)

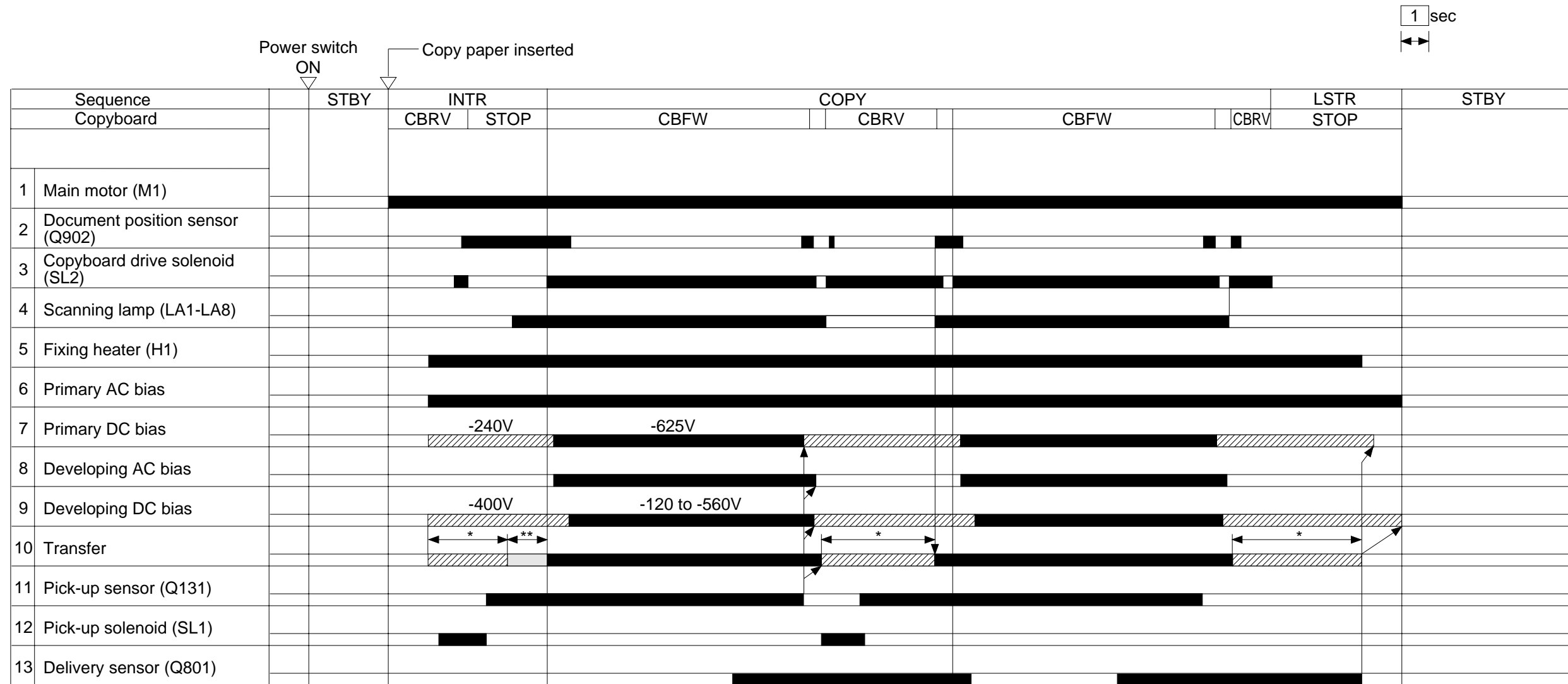

* Cleaning mode.
** Measurement mode.

B. SIGNALS/ABBREVIATIONS LIST

What follows below is a list of signals and abbreviations used in the chapters of the manual and circuit diagrams.

The abbreviations within parentheses represent analog signals, which cannot be expressed in terms of '1' or '0'.

1. Signals

ACBTP	AC BIAS TIMING PULSE COMMAND
[AE]	AE SIGNAL
CBSD	COPYBOARD DRIVE SOLENOID DRIVE COMMAND
DCBPWM	DC BIAS CONTROL COMMAND
DCTPWM	TRANSFER DC BIAS CONTROL COMMAND
DGT0	OSCILLATION SIGNAL 0
DGT1	OSCILLATION SIGNAL 1
DGT2	OSCILLATION SIGNAL 2
HTRD	FIXING HEATER DRIVE COMMAND
HVPAC	PRIMARY AC BIAS ON COMMAND
HVPDC	PRIMARY DC BIAS ON COMMAND
HVPHO	PRIMARY DC BIAS HIGH OUTPUT COMMAND
HVTDC	TRANSFER DC BIAS ON COMMAND
KEYR0	RETURN SIGNAL 0
KEYR1	RETURN SIGNAL 1
LAPWM	LAMP DRIVE COMMAND
[LID]	LAMP INTENSITY DETECTION SIGNAL
MMCLK	MAIN MOTOR CLOCK PULSE SIGNAL
MMD	MAIN MOTOR DRIVE COMMAND
PWOFF	POWER OFF COMMAND
PWSON	POWER SWITCH ON SIGNAL
PUSD	PICK-UP ROLLER SOLENOID DRIVE COMMAND
RELAYED	RELAY DRIVE COMMAND
RGSD	REGISTRATION SOLENOID DRIVE COMMAND
[TH1]	THERMISTOR SIGNAL 1
TREV	TRANSFER REVERSE DC BIAS ON COMMAND
VPEAK	VOLTAGE PEAK DETECT SIGNAL
ZXDP	ZERO CROSS DETECTION SIGNAL

2. Abbreviations

INTR	INITIAL ROTATION
LSTR	LAST ROTATION
CBFW	COPYBOARD FORWARD
CBRV	COPYBOARD REVERSE
STBY	STANDBY

C. GENERAL CIRCUIT DIAGRAM

PC400/FC200 GENERAL CIRCUIT DIAGRAM

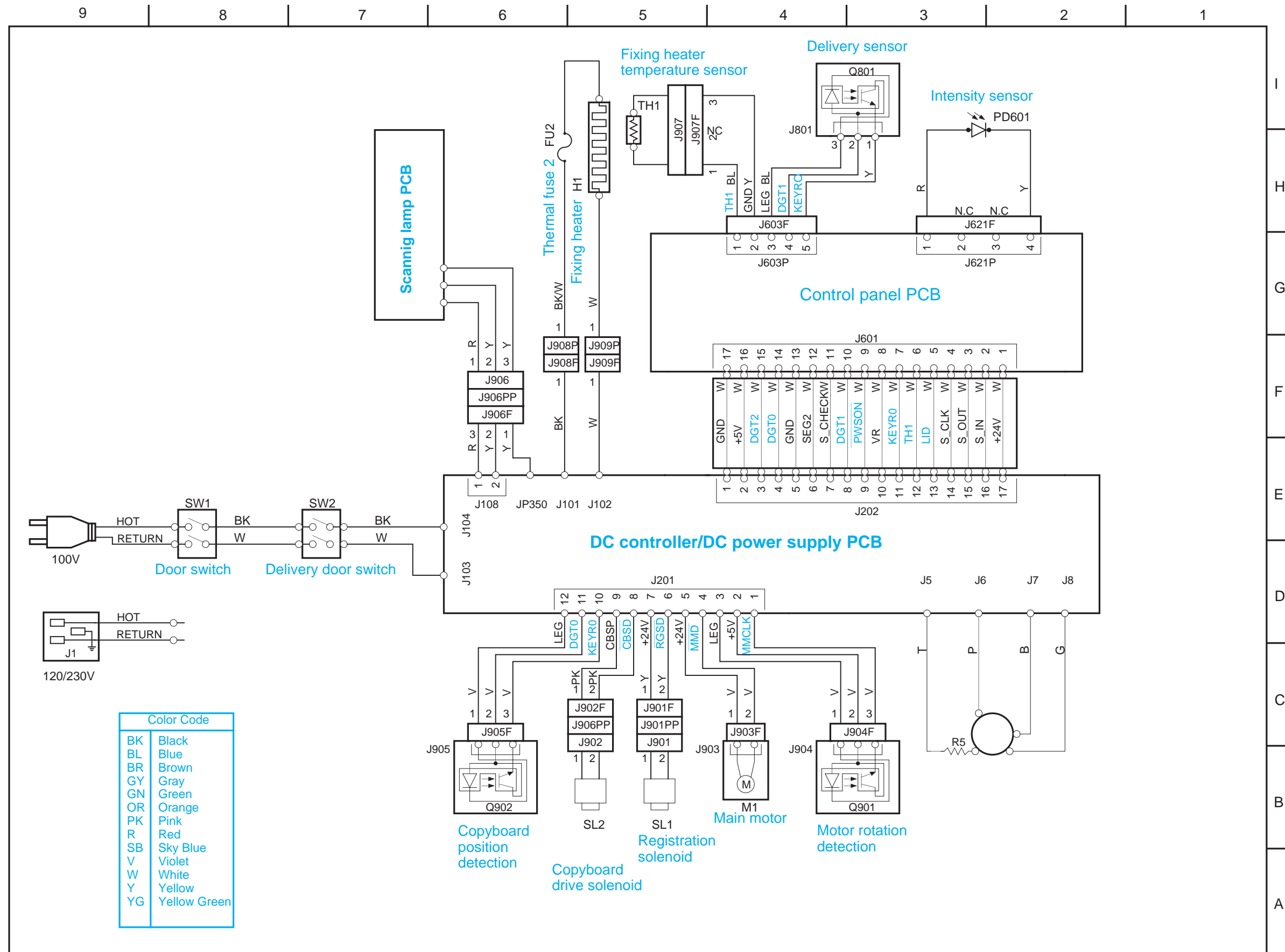

PC420/430/FC220 GENERAL CIRCUIT DIAGRAM

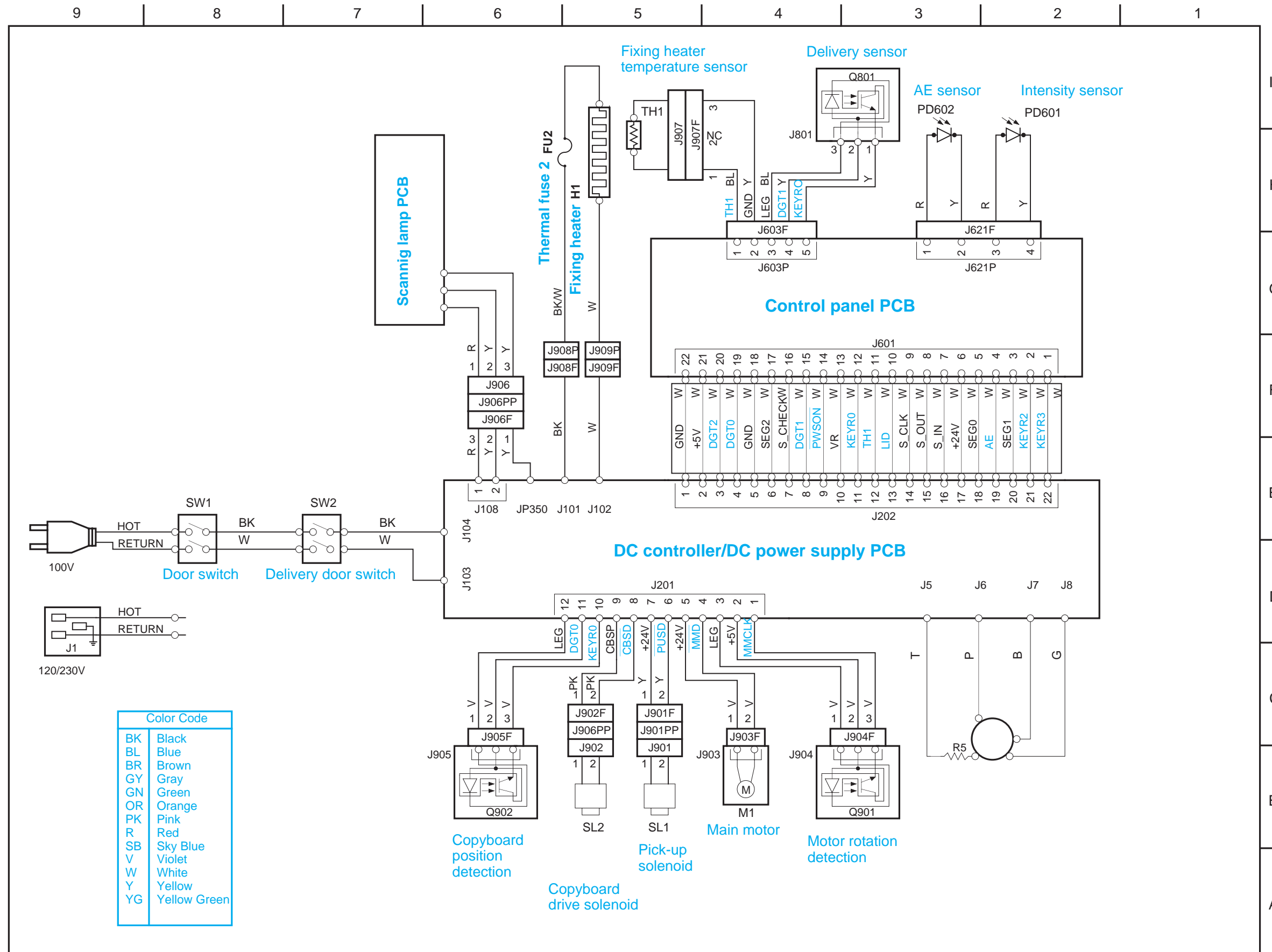

D. SPECIAL TOOLS TABLE

What follows below is a table of special tools used for servicing the machine in addition to the standard tools set.

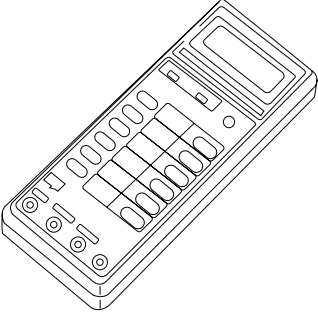
No.	Tool name	Tool Number	Shape	Category*	Remarks
1	Digital multimeter	CK-0552		B	For adjusting the AE mechanism.

*The tools are categorized as follows:

- A: tools that must be carried by each service person.
- B: tools that must be carried by a group of about five service persons.
- C: tools that must be kept by each workshop.

E. SOLVENTS/OILS TABLE

No.	Name	Uses	Composition	Remarks
1	Alcohol	Cleaning: e.g., glass, plastic, rubber parts; external covers	Hydrocarbon (fluorine family) Alcohol Surface active agent	<ul style="list-style-type: none"> • Do not bring near fire. • Procure locally. • Isopropyl alcohol may be substituted.
2	Solvent	Cleaning: e.g., metal; oil or toner dirt	Hydrocarbon (fluorine/chlorine family) Alcohol	<ul style="list-style-type: none"> • Do not bring near fire. • Procure locally.
3	Heat-resisting grease	Lubricating: drive assemblies	Lithium soap (mineral oil family) Molybdenum bisulfate	<ul style="list-style-type: none"> • CK-0427 (500 g/can)
4	Lubricating oil		Mineral oil (paraffin family)	<ul style="list-style-type: none"> • CK-0451 (100 cc)
5	Lubricating oil		Mineral oil (paraffin family)	<ul style="list-style-type: none"> • CK-0524 (100 cc)

Prepared by
OFFICE IMAGING PRODUCTS TECHNICAL SUPPORT DEPARTMENT 1
OFFICE IMAGING PRODUCTS TECHNICAL SUPPORT DIVISION
CANON INC.
Printed in Japan

REVISION 0 (JAN. 1998) [23715]

5-1, Hakusan 7-chome, Toride-shi, Ibaraki 302 Japan

Canon



This publication is printed on
70% reprocessed paper.