

**EPSON**  
EXCEED YOUR VISION

9-pin Dot Matrix Printer

**LX-300+II** .....

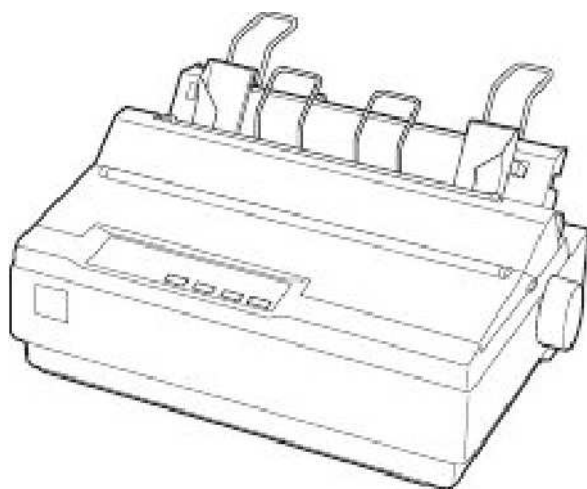

## Reference Guide

All rights reserved. No part of this publication may be reproduced, stored in a retrieval system, or transmitted in any form or by any means, electronic, mechanical, photocopying, recording, or otherwise, without the prior written permission of Seiko Epson Corporation. The information contained herein is designed only for use with this Epson printer. Epson is not responsible for any use of this information as applied to other printers.

Neither Seiko Epson Corporation nor its affiliates shall be liable to the purchaser of this product or third parties for damages, losses, costs, or expenses incurred by the purchaser or third parties as a result of: accident, misuse, or abuse of this product or unauthorized modifications, repairs, or alterations to this product, or (excluding the U.S.) failure to strictly comply with Seiko Epson Corporation's operating and maintenance instructions.

Seiko Epson Corporation shall not be liable for any damages or problems arising from the use of any options or any consumable products other than those designated as Original Epson Products or Epson Approved Products by Seiko Epson Corporation.

Epson and Epson ESC/P are registered trademarks, and Exceed Your Vision is a trademark of Seiko Epson Corporation.

Epson Store is a service mark of Epson America, Inc.

*General Notice: Other product names used herein are for identification purposes only and may be trademarks of their respective owners. Epson disclaims any and all rights in those marks.*

---

# Contents

## **Introduction**

---

About This Manual . . . . .	6
Warnings, Cautions, and Notes . . . . .	7
Safety Instructions . . . . .	7
Hot parts caution symbol . . . . .	7
When setting up the printer . . . . .	8
When operating the printer. . . . .	9
When handling paper . . . . .	9
When maintaining the printer . . . . .	10

## **Chapter 1 Paper Handling**

---

Printing on Continuous Paper . . . . .	11
Printing with the push tractor . . . . .	12
Printing with the pull tractor . . . . .	17
Adjusting the top-of-form position . . . . .	22
Advancing paper to the tear-off edge . . . . .	23
Printing on Single Sheets . . . . .	26
Printing on Special Paper . . . . .	29
Adjusting the paper thickness lever . . . . .	29
Multipart forms. . . . .	30
Labels . . . . .	31
Envelopes. . . . .	32

## **Chapter 2 Using the Printer Software**

---

Accessing the Printer Driver . . . . .	34
From Windows applications. . . . .	34
From the Start menu . . . . .	36
Changing the Printer Driver Settings. . . . .	38

Using EPSON Status Monitor 3 .....	41
Setting up EPSON Status Monitor 3 .....	42
Accessing EPSON Status Monitor 3 .....	43
Installing EPSON Status Monitor 3 .....	44
Setting Up Your Printer on a Network .....	45
Setting up the printer server .....	45
Setting up the clients .....	49
Installing the printer driver from the CD-ROM .....	57
Canceling Printing .....	58
Uninstalling the Printer Software .....	59
Uninstalling the printer driver and EPSON Status Monitor 3 .....	59

### *Chapter 3 Using the Control Panel*

---

Control Panel Buttons and Lights .....	63
Selecting a built-in font .....	65
Changing the Default Settings .....	67
Using Default Setting mode .....	72
Restoring the printer's default settings .....	73

### *Chapter 4 Maintenance and Troubleshooting*

---

Cleaning the Printer .....	74
Transporting the Printer .....	75
Troubleshooting .....	76
Using the error indicators .....	77
Problems and solutions .....	79
Clearing a paper jam .....	93
Printing a self test .....	94
Where To Get Help .....	96
Internet support .....	96
Speak to a support representative .....	96
Purchase supplies and accessories .....	97

*Chapter 5 Options and Consumables*

---

Cut-sheet Feeder .....98  
Optional Tractor .....102  
Roll Paper Holder .....104  
Replacing the Ribbon Cartridge .....105

*Chapter 6 Product Information*

---

Printer Parts .....109  
Specifications .....111  
    Mechanical.....111  
    Electronic .....113  
    Electrical .....115  
    Environmental .....115  
    Paper .....115  
    Printable area .....119  
    Paper alignment .....121  
Command Lists .....122  
    EPSON ESC/P control codes .....122  
    IBM 2380 Plus emulation control codes .....123  
Standards and approvals .....125  
    Safety approvals .....125  
    CE marking .....125  
  
**Index**.....126

---

## **Introduction**

Your Epson® LX-300+II printer provides high-quality printing and superior performance in a compact design. This 9-pin dot matrix printer provides:

- ❑ A variety of paper paths to suit your printing needs.
- ❑ The ability to handle a wide range of paper types, including continuous paper, multipart forms (with one original and up to four copies), labels, single sheets, and envelopes.
- ❑ High-speed printing of up to 300 cps (characters per second) at 10 cpi (characters per inch).

The CD-ROM that came with your printer contains the printer driver for Microsoft® Windows® 98, Me, 2000, XP and NT 4.0, plus the EPSON Status Monitor 3 utility.

---

## **About This Manual**

This manual provides detailed information about your printer:

- ❑ Chapter 1, "Paper Handling," explains how to load various types of paper.
- ❑ Chapter 2, "Using the Printer Software," describes how to print using the printer software.
- ❑ Chapter 3, "Using the Control Panel," provides information about the control panel functions, including how to change the printer's default settings.
- ❑ Chapter 4, "Maintenance and Troubleshooting," includes basic maintenance procedures and solutions to possible problems.

- ❑ Chapter 5, “Options and Consumables,” describes how to use options such as the roll paper holder and cut-sheet feeder, and explains how to replace the ribbon cartridge.
- ❑ Chapter 6, “Product Information,” contains technical information about the printer.

For setup instructions and basic information, please see the *User’s Guide*.

## **Warnings, Cautions, and Notes**



### **Warnings**

*must be followed carefully to avoid bodily injury.*



### **Cautions**

*must be observed to avoid damage to your equipment.*

### **Notes**

*contain important information and useful tips on the operation of your printer.*

---

## **Safety Instructions**

Read all of these safety instructions before using the printer and follow all warnings and instructions marked on the printer.

### **Hot parts caution symbol**



This symbol is placed on the print head and other parts to indicate that they may be hot. Never touch these parts just after the printer has been used. Let them cool for a few minutes before touching them.

## ***When setting up the printer***

- ❑ Do not place the printer on an unstable surface or near a radiator or heat source.
- ❑ Place the printer on a flat, stable surface. It will not operate properly if it is tilted or placed at an angle.
- ❑ Do not place the printer on a soft surface like a bed or a sofa, or a small, enclosed area, as this restricts ventilation.
- ❑ Do not block or cover the slots and openings in the printer's cabinet, and do not insert objects through the slots.
- ❑ Use only the type of power source indicated on the printer's label. If you are not sure of the power supply specifications in your area, contact your local power company or consult your Epson reseller.
- ❑ Connect all equipment to properly grounded electrical outlets. Avoid using outlets on the same circuit as photocopiers or air control systems that regularly switch on and off.
- ❑ Do not use a damaged or frayed power cord.
- ❑ The power cord should be placed to avoid abrasions, cuts, fraying, crimping, kinking, and other damage.
- ❑ If you use an extension cord with the printer, make sure the total ampere rating of all devices plugged into the extension cord does not exceed the cord's ampere rating. Also, make sure the total ampere of all devices plugged into the electrical outlet does not exceed the electrical outlet's ampere rating.
- ❑ Use only the power cord that comes with this product. Use of another cord may result in fire or electric shock.



## ***When operating the printer***

- ❑ Adjust only those controls that are covered in the user documentation. Improper adjustment of other controls may result in damage requiring extensive repair by a qualified technician.
- ❑ Whenever you turn off the printer, wait at least five seconds before turning it back on; otherwise, you may damage it.
- ❑ Do not turn off the printer while it is printing the self test. Always press the PCause button to stop printing and then turn off the printer.
- ❑ Do not reconnect the power cord to an electrical outlet that has the wrong voltage for your printer.
- ❑ Never replace the print head yourself; you may damage the printer. Also, other parts of the printer must be checked when the print head is replaced.
- ❑ You may need to move the print head by hand to replace the ribbon cartridge. If you have just used the printer, the print head may be hot; let it cool before touching it.

## ***When handling paper***

- ❑ Because labels are sensitive to temperature and humidity, use them only under these normal operating conditions:  
  
Temperature: 59 to 77°F (15 to 25°C)  
Humidity: 30 to 60% RH
- ❑ Do not leave labels in the printer between jobs; they may curl around the platen and jam when you resume printing.
- ❑ Do not load paper that is curled or has been folded.

## ***When maintaining the printer***

- ❑ Unplug the printer before cleaning it, and always clean it with a damp cloth only.
- ❑ Do not spill liquid onto the printer.
- ❑ Except as specifically explained in this manual, do not attempt to service the printer yourself.
- ❑ Unplug the printer and refer servicing to qualified service personnel under the following conditions:
  - i. If the power cord or plug is damaged.
  - ii. If liquid has entered the printer.
  - iii. If the printer has been dropped or the cabinet damaged.
  - iv. If the printer does not operate normally or exhibits a distinct change in performance.
- ❑ Do not use aerosol blowers which contain flammable gas inside or around this product. Doing so may cause fire.
- ❑ Adjust only those controls that are covered by the operating instructions.

### **Paper Handling**

Your printer can handle continuous paper in either the push or the pull position, as well as single sheets and special papers such as labels and envelopes.

For instructions on using continuous paper, see the following section. To load single sheets, see page 26. For information about special paper, see page 29.

---

### **Printing on Continuous Paper**

You can print on continuous paper using the tractor in either the push or pull position:

- ❑ Use the tractor in the push position if you want to be able to switch between printing on single sheets and continuous paper without removing the paper supply, or if you will be tearing off continuous paper sheet-by-sheet. (Follow the instructions in the next section.) The printer comes with the tractor installed in the push position.
- ❑ Use the tractor in the pull position if you will be printing on labels, multipart forms, or other documents that require a precise print position. (See “Printing with the pull tractor” on page 17 for instructions.)

## ***Printing with the push tractor***

Follow these steps to load continuous paper on the push tractor:

1. Turn off the printer.
2. Remove the printer cover and the paper guide, and pull the paper release lever forward to the continuous paper position.

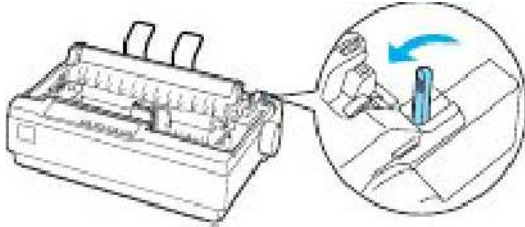

3. Unlock the sprockets on the tractor by pulling the blue lock levers forward.

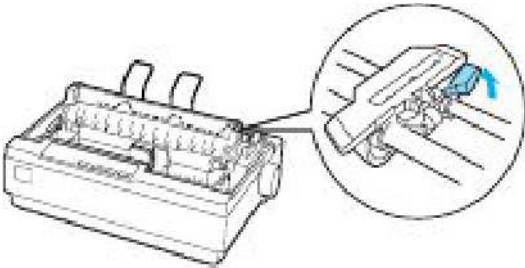

- Slide the left sprocket so the pins are aligned with the 0 mark on the printer scale (which is beneath the tractor). Push the lock lever back to lock it in place. Then slide the right sprocket to match the width of your paper, but do not lock it. Move the paper support so it is midway between the sprockets.

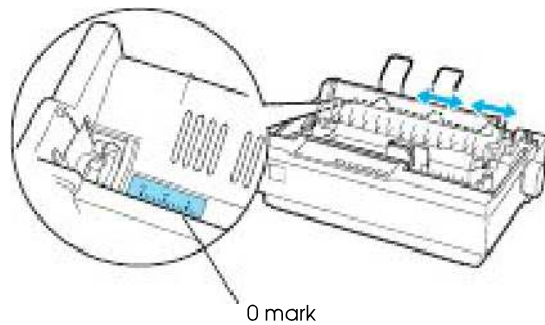

- Stack your continuous paper behind the printer. Make sure there are no obstructions between the paper and the printer and that the paper is aligned squarely with the printer so it will feed in straight.
- Make sure your paper has a clean, straight, leading edge. Then open the sprocket covers and fit the first holes of the paper over the sprocket pins.

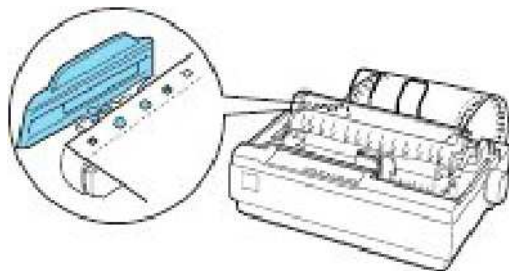

- Close the covers. Slide the right sprocket to remove any slack in the paper and lock it in place.

8. To separate the incoming paper from the printed paper, attach the paper guide by holding it horizontally and fitting its notches over the printer's mounting posts as shown below. Then slide the paper guide toward the front of the printer until you feel it click.

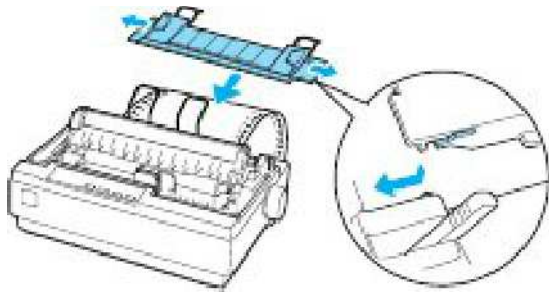

9. Replace the printer cover and close it.
10. Turn on the printer.
11. When using the push tractor, it is a good idea to turn on the Auto tear off feature in Default Setting mode. See page 67.
12. Press the LF/FF button to feed the paper to the loading position. When the printer receives data, it begins printing automatically.
13. After you finish printing, follow the steps in the next section to tear off your printed document. If the first printed line on your page appears too high or too low, you can change its position using the Micro Adjust feature. See "Adjusting the top-of-form position" on page 22.



**Caution:**

*Never use the paper feed knob to adjust the top-of-form position; this may damage the printer or cause it to lose the top-of-form position.*

The next time you print, the paper automatically feeds back to the loading position.

## Removing a printed document from the push tractor

Follow these steps to remove the printed document:

1. Press the Tear Off (Font) button. The Tear Off (Font) lights start flashing. (This indicates that your paper is at the current tear-off position.)
2. Open the printer cover and tear off the printed document using the tear-off edge on the paper tension unit.

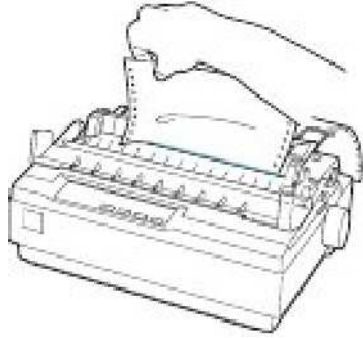

### **Note:**

*If your paper's perforation is not properly aligned with the tear-off edge, you can adjust the tear-off position using the Micro Adjust feature. See "Adjusting the tear-off position" on page 25.*



### **Caution:**

*Never use the paper feed knob to adjust the tear-off position; this may damage the printer or cause it to lose the tear-off position.*

3. Close the printer cover.

When you resume printing, the printer automatically feeds the paper back to the top-of-form position and starts printing.

To feed continuous paper backward to the standby position, where you can remove the paper, first tear off any printed sheets. Then press the Load/Eject button. Open the sprocket covers on the tractor and remove the paper.



**Caution:**

*Always tear off your printed document before you press the Load/Eject button. Reverse feeding several pages at a time may cause a paper jam.*

### **Switching between continuous paper and single sheets**

If you want to switch to single sheets while continuous paper is loaded in the push tractor position, follow these steps:

1. Tear off your printed document.



**Caution:**

*Always tear off your printed document before you press the Load/Eject button. Reverse feeding several pages at a time may cause a paper jam.*

2. Press the Load/Eject button to feed the paper backward to the standby position.
3. Push the paper release lever back to the single sheet position.
4. Follow the instructions on page 26 to load single sheets.

To switch back to continuous paper, follow these steps:

1. Press the Load/Eject button to eject any sheet in the printer.
2. Move the paper release lever to the continuous paper position.
3. Press the LF/FF button to load the paper on the tractor.



## ***Printing with the pull tractor***

To load continuous paper using the pull tractor, you must move the tractor to the pull tractor position, as described below. If your tractor is already installed in this position, make sure the printer is turned off and skip to step 6.

1. Turn off the printer.
2. Remove the printer cover and the paper guide.
3. Remove the paper tension unit by gently squeezing the lock tabs and pulling it out of the printer.

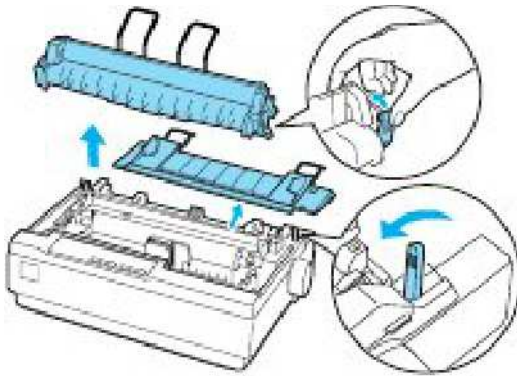

4. Pull the paper release lever forward to the continuous paper position.

5. To remove the tractor from the push position, gently squeeze the lock tabs on both sides and then rotate the tractor up to pull it away from the printer.

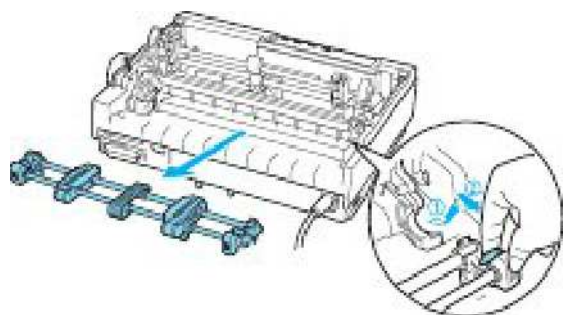

6. Lower the tractor onto the mounting slots at the top of the printer as shown below, and tilt it back until you feel it lock into place.

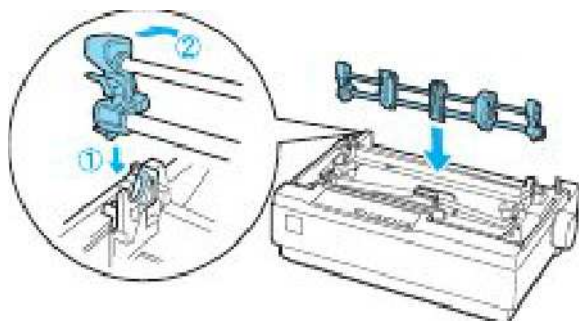

7. Unlock the sprockets by pulling the blue lock levers forward.

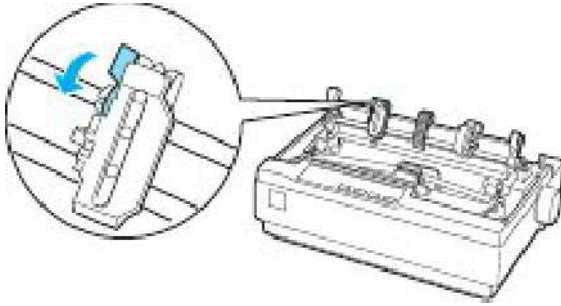

8. Feed the paper into the rear paper slot as shown below, and pull it up. Position the paper using the scale on the printer as a guide. Printing starts to the right of the position marked 0 (under the paper now).

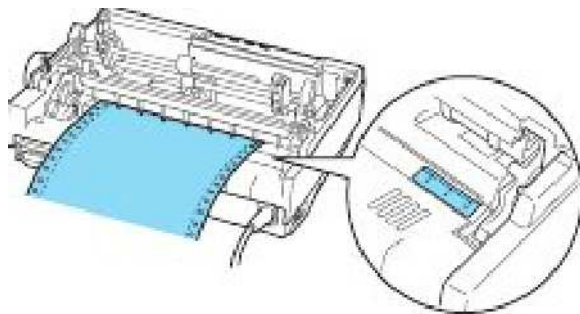

- Slide the left sprocket so its pins are aligned with the holes in the paper and push the blue lock lever to lock the sprocket in place. Then slide the right sprocket to match the width of your paper, but do not lock it. Move the paper supports midway between the two sprockets.

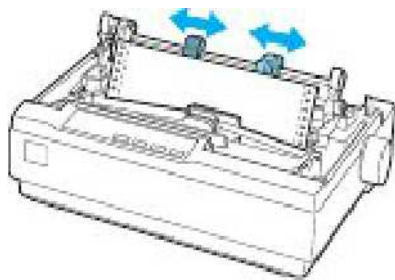

- Make sure your paper has a clean, straight leading edge. Open the sprocket covers. Fit the first holes of the paper over the sprocket pins and then close the sprocket covers. Slide the right sprocket to remove any slack in the paper and then lock it in place.

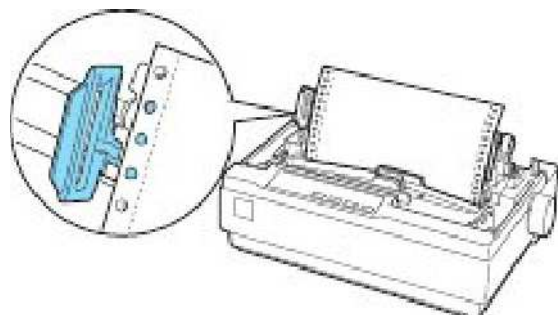

**Note:**

*Remove any remaining slack by gently pulling the paper from the back.*

11. To separate the incoming paper from the printed paper, attach the paper guide. Hold it horizontally and fit its notches over the printer's mounting posts. Then slide the paper guide toward the back of the printer until you feel it click.
12. Turn the paper feed knob to adjust the paper position. The perforation between pages should be just above the print head.
13. Replace the printer cover but leave it open.
14. Turn on the printer.
15. Set the Auto tear off feature in the Default Setting mode to Off; otherwise, the paper may jam. (See page 67 for more information.)

When the printer receives data, it begins printing automatically. If you want to change the position where printing begins on the page, press the LF/FF button to advance the page to the next top-of-form position, and then see the next section to adjust the loading position.

To eject the paper, tear off the paper entering the printer; then press the LF/FF button to feed the paper forward.



## Adjusting the top-of-form position

The top-of-form position is the position on the page where the printer starts printing. If your printing appears too high or too low on the page, you can use the Micro Adjust mode to adjust the top-of-form position.



**Caution:**

*Never use the paper feed knob to adjust the top-of-form position; this may damage the printer or cause it to lose the top-of-form position.*

1. Make sure the printer is turned on and paper is loaded.
2. Remove the printer cover.
3. Hold down the **PAUSE** button for about three seconds. The printer beeps and the Pause light starts flashing as the printer enters Micro Adjust mode.
4. Press the **LF/FF**  button to move the top-of-form position higher on the page, or press the **LOAD/EJECT**  button to move the top-of-form position lower on the page.

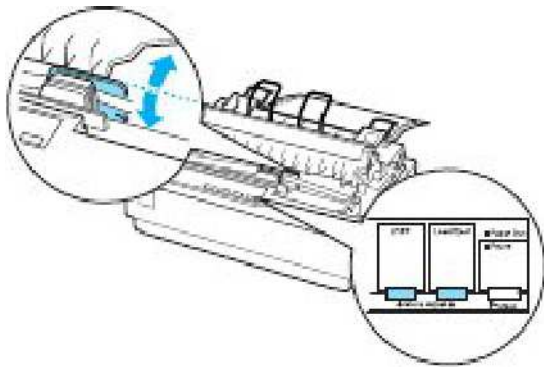

**Note:**

- ❑ *The printer has a minimum and a maximum top-of-form position. If you try to adjust it beyond these limits, the printer beeps and stops moving the paper.*
  - ❑ *When the paper reaches the default top-of-form position, the printer beeps and stops moving the paper briefly. You can use the default position as a reference point when adjusting the top-of-form position.*
5. After you set the top-of-form position, press the Pause button to exit Micro Adjust mode.

**Note:**

- ❑ *Your top-of-form position setting remains in effect until you change it, even if you turn off the printer.*
- ❑ *The top margin setting made in some software applications overrides the top-of-form position setting you make with the Micro Adjust feature. If necessary, adjust the top-of-form position in your software.*
- ❑ *If you want to restore the printer's default top-of-form position, you can reset the printer. See page 73 for instructions.*

## **Advancing paper to the tear-off edge**

When the push tractor is installed, you can use the tear-off feature to advance your continuous paper to the printer's tear-off edge when you finish printing. You can then easily tear off the printed document. When you resume printing, the printer automatically feeds the paper back to the top-of-form position; so you can save the paper normally lost between documents.

You can use the tear-off feature in two ways:

- ❑ Manually, by pressing the printer's Tear Off (Font) button
- ❑ Automatically, by turning on the Auto tear-off function in Default-setting mode.

### **Using the Tear Off button**

After the printer finishes printing your document, check that the Tear Off (Font) lights are not flashing. Then press the Tear Off (Font) button. The printer advances the paper to the tear-off edge.

**Note:**

*If the Tear Off (Font) lights are flashing, the paper is in the tear-off position. If you press the Tear Off (Font) button again, the printer feeds your paper to the next top-of-form position.*

### **Advancing paper to the tear-off position automatically**

To automatically advance your printed documents to the tear-off position, you need to turn on the Auto tear-off mode and select the appropriate page length for continuous paper in Default Setting mode. For instructions, see page 67.

When Auto tear-off is on, the printer automatically advances the paper to the tear-off position whenever it receives a full page of data or a form feed command followed by no more data.



## Adjusting the tear-off position

If your paper's perforation is not aligned with the tear-off edge, you can use the Micro Adjust mode to move the perforation to the tear-off position. Follow these steps:

1. Make sure the Tear Off (Font) lights are flashing. You may need to press the Tear Off (Font) button to advance the paper to the tear-off position.
2. Open the printer cover.
3. Hold down the PAUSE button for about three seconds. The printer beeps and the Pause light begins to flash as the printer enters Micro Adjust mode.
4. Press the LF/FF  $\blacktriangledown$  button to feed the paper backward, or press the LOAD/EJECT  $\blacktriangleup$  button to feed the paper forward, until the paper perforation is aligned with the tear-off edge on the paper tension unit.

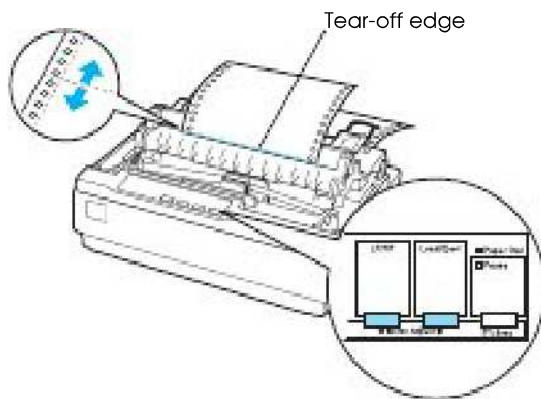

**Note:**

*The printer has a minimum and a maximum tear-off position. If you try to adjust the tear-off position beyond these limits, the printer beeps and stops moving the paper.*

5. After you set the tear-off position, press the **PAUSE** button to exit Micro Adjust mode.
6. Tear off the printed pages.

When you resume printing, the printer automatically feeds the paper back to the top-of-form position and begins printing.

**Note:**

*Your tear-off position setting remains in effect until you change it, even if you turn off the printer. (If you want to restore the printer's default tear-off position, you can reset the printer. See page 73 for instructions.)*

---

## **Printing on Single Sheets**

You can load single sheets of paper one at a time using the printer's paper guide.

Before printing on single-sheet multipart forms, envelopes, or other special paper, make sure the paper thickness lever is set to the correct position. See "Printing on Special Paper" on page 29.

**Note:**

- Load only one sheet at a time.*
- To load a stack of single-sheet paper, use the optional cut-sheet feeder. (See page 98 for more information.)*
- For detailed specifications on the types of single-sheet paper you can use, see page 115.*
- You can use the paper guide to load single-sheet carbonless multipart forms that are fastened at the top by line gluing.*
- Insert multipart forms in the paper guide, bound edge first and printable side down.*

Follow these steps to load a single sheet:

1. If continuous paper is loaded in the push tractor, press the Load/Eject button to feed it back to the standby position.
2. Push the paper release lever back to the single-sheet position and make sure the paper guide is in the upright position, as shown below.

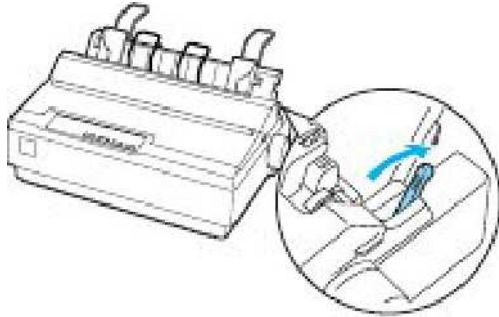

3. Slide the left edge guide until it locks in place at the guide mark. Then adjust the right edge guide to match the width of your paper.

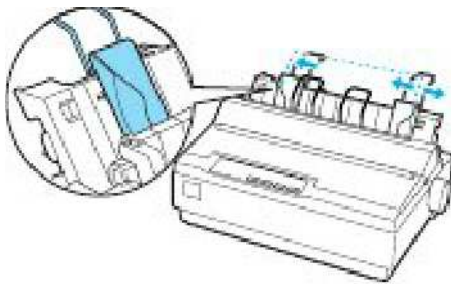

4. Insert a sheet of paper between the edge guides until it meets resistance. The printer automatically pulls it into the correct printing position.

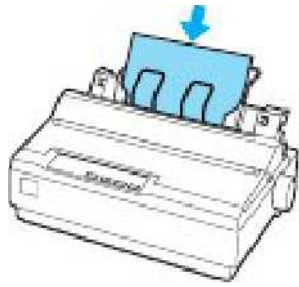

When the printer receives data, it begins printing. If the document is more than one page, the printer beeps three times after printing each page. Load the next sheet and the printer will continue printing.



**Caution:**

*Use the paper feed knob on the right side of the printer only to clear paper jams and only when the printer is off. Otherwise, you may damage the printer or cause it to lose the top-of-form position.*

---

## Printing on Special Paper

With the LX-300+II, you can print on a wide variety of special paper types, including multipart forms, labels, and envelopes.



### **Caution:**

*When printing on multipart forms, thicker-than-normal paper, labels, or envelopes, make sure your application software settings keep the printing entirely within the printable area. Printing past the edge of these papers can damage the print head.*

## Adjusting the paper thickness lever

Before printing on special paper, you need to make sure the paper thickness lever is set correctly for the type of paper you're using. Follow these steps:

1. Lift up or remove the printer cover. The paper thickness lever is on the left side of the printer.

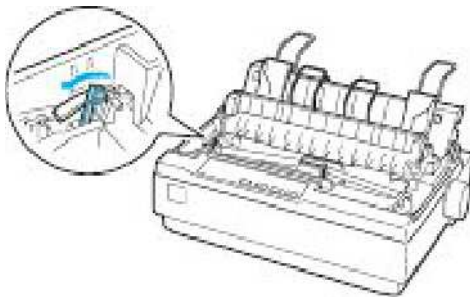

2. The numbers next to the lever indicate the thickness setting. Use the table below to select the appropriate paper thickness.

Paper type	Lever position
Standard paper (single sheets or continuous)	0
Multipart forms 2-sheet	0
3-sheet	1
4-sheet	2
5-sheet	3
Labels	1
Envelopes	2 or 4

3. Close the printer cover.

## **Multipart forms**

You can use continuous or single-sheet carbonless multipart forms of up to five parts (one original plus four copies). Follow these guidelines:

- Set the paper thickness lever to the correct position for your forms. (See page 29.)
- Use continuous multipart forms that are joined only by spot gluing or side-crimping. Never load continuous multipart forms joined by metal staples, tape, or continuous gluing.
- Use single-sheet multipart forms that are line-glued only at the top. Insert the forms glued-edge-first into the printer.
- Make sure that multipart forms are not wrinkled.

- ❑ If you need to adjust the loading position, use your application software, or change the loading position as described on page 22.
- ❑ When you use side-crimped continuous multipart forms, the copies may not align with the original. If this happens, raise the paper guide.

For multipart forms, you should not print any closer than 0.5 inch (13 mm) from either side of the paper. For information on the printable area of envelopes, see the paper specifications on page 115.

## **Labels**

To print on labels, you must use continuous paper loaded on the pull tractor. Keep the following tips in mind:

- ❑ Set the paper thickness lever to the correct position for labels. (See page 29.)
- ❑ Choose labels mounted on a continuous backing sheet with sprocket holes designed for tractor use. Do not print labels as single sheets, because the shiny backing causes the paper to slip slightly.
- ❑ Load labels the same way you load ordinary continuous paper. See “Printing with the pull tractor” on page 17 for loading instructions.
- ❑ Because labels are especially sensitive to temperature and humidity, use them only under normal operating conditions.
- ❑ Do not leave labels loaded in the printer between jobs; they curl around the platen and may jam when you resume printing.

- ❑ To remove the labels from the printer, tear off the fresh supply at the back of the printer; then press the LF/FF button to advance the remaining labels out of the printer.



**Caution:**

*Never feed labels backward through the printer; they can easily peel off the backing sheet and jam the printer.*

## **Envelopes**

You can feed envelopes individually using the paper guide. Keep the following tips in mind:

- ❑ Set the paper thickness lever to the proper position. See page 29.
- ❑ To load an envelope, follow the steps on page 26 for printing a single sheet. Insert the wide edge of the envelope into the printer first, printable-side down. When you insert the envelope between the edge guides, push it firmly and hold it until it feeds into the printer.
- ❑ Use envelopes only under normal temperature and humidity conditions.
- ❑ Make sure the printing stays entirely within the printable area.
- ❑ The print head must not go past the left or right edge of the envelope or other thick paper. It's a good idea to print a test page using a normal single sheet of paper before you print on envelopes.



---

### **Using the Printer Software**

The Epson software includes the printer driver software and EPSON Status Monitor 3. The printer driver allows your computer to control the printer and enables your Windows software applications to take full advantage of the printer's capabilities.

Status Monitor 3 lets you monitor the status of your printer, alerts you when errors occur, and provides you with troubleshooting tips. It is automatically installed when you install the printer driver.

**Note:**

- ❑ *Before proceeding, make sure you have installed the printer software on your computer as described in the User's Guide.*
- ❑ *Make sure the software setting is set to ESC/P. The printer driver software and EPSON Status Monitor 3 can function only in ESC/P mode. (See page 67 for more information.)*
- ❑ *Windows NT does not support the USB interface.*

---

## Accessing the Printer Driver

You can access the printer driver from your Windows applications or from the Start menu:

- ❑ When you access the printer driver from a Windows application, any settings you make apply only to the application you are using. See “From Windows applications” on page 34 for more information.
- ❑ When you access the printer driver from the Start menu, the printer driver settings you make apply to all your applications. See “From the Start menu” on page 36 for more information.

**Note:**

*While many Windows applications override the settings made with the printer driver, some do not. Check your printer driver settings to make sure they are correct for your document.*

### From Windows applications

Follow these steps to access the printer driver from a Windows application:

1. Select Print or Print Setup from the File menu of your application.

2. Make sure your printer is selected in the Name drop-down list:



3. Click Printer, Setup, Properties, or Options. (The button you click depends on your application and you may need to click a combination of these buttons.) The Properties window appears:



Windows 98 or Me

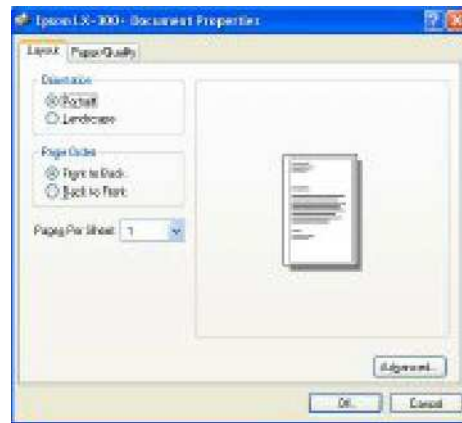

Windows 2000, XP, or NT 4.0

4. To view a menu, click the corresponding tab at the top of the window. See "Changing the Printer Driver Settings" on page 38 for more information.

## ***From the Start menu***

Follow these steps to access the printer driver from the Start menu:

1. For Windows 98, Me, 2000, or NT, click Start > Settings > Printers.

For Windows XP Professional, click Start > Settings > Printers and Faxes.

For Windows XP Home Edition, click Start > Printers and Faxes.

2. In Windows 98 or Me, right-click your printer icon and click Properties. The screen displays the Properties window:



In Windows 2000 or XP, right-click your printer icon and click Printing Preferences. In Windows NT, right-click the icon and select Document Defaults. You see the Document Properties window:

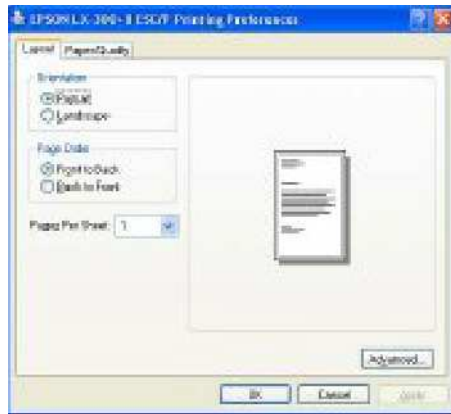

In Windows 2000, XP, or NT, you can also click Properties to display the Properties window:

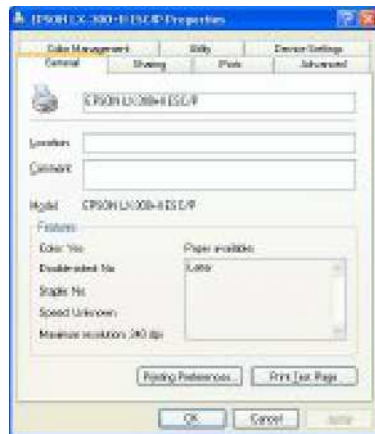

3. To view a menu, click the corresponding tab at the top. See "Changing the Printer Driver Settings" on page 38 for more information.

---

## Changing the Printer Driver Settings

The following table shows the printer driver settings. Note that not every setting is available in all versions of Windows.

Setting	Explanation
Paper Size	Select the paper size you want to use. If you don't see your paper size, use the scroll bar to scroll through the list. If your paper size is not included in the list, see "Defining a custom paper size" on page 40.
Orientation	Select <b>Portrait</b> or <b>Landscape</b> .
Paper Source	Select the paper source you want to use.
Resolution/ Graphics Resolution	Select the printing resolution you want. The higher the resolution you select, the more detailed your printout will be. However, increasing the resolution slows printing.
Dithering	You can leave this option set to <b>Fine</b> , which is the default setting, or select another dithering pattern for the kind of printout you want.
Intensity	Move the slider to make your printout lighter or darker.
Print Quality	Select a print quality option from the Print quality list. Set Hi-speed to <b>On</b> to use bidirectional printing, which increases the print speed. Setting Hi-speed to <b>Off</b> selects unidirectional printing mode, which is slower but more precise. Printing with the default settings uses the settings stored in the printer.
Halftone Setup.../ Halftone Color Adjustment...	Click this button to set the brightness and contrast, input the RGB gamma, or make other settings. The Halftone Color Adjustment window appears. For details, click the <b>Help</b> button in this window.
Halftoning	Select the type of halftoning to use when printing graphics. To let the printer determine the best halftone quality, use <b>Auto Select</b> .

Setting	Explanation
Printer Font Setting	<p>Select a character table group to use: <b>Standard</b>, <b>Expanded</b>, and <b>None</b> (Bit Image printing).</p> <p>When <b>Standard</b> or <b>Expanded</b> is selected, the printer uses the device fonts. Expanded includes more fonts than Standard.</p> <p>When <b>None is</b> selected, the printer uses bit map images instead of the device fonts.</p> <p>For details on the fonts included in each table, see page 113.</p>
Print Text as Graphics*	Select <b>Off</b> when the printer uses the device fonts or <b>On</b> when it doesn't use the device fonts.
Metafile Spooling*	Select whether to use EMF spooling.
Paper Order*	Select whether to print from front to back or back to front.
Pages Per Sheet*	Select the number of pages that you want to print on a single sheet of paper.
Copy Count*	When you select more than one in the <b>Number of copies</b> box, this check box appears and you can select whether to collate the pages of the copies.
Advanced Printing Features*	Select <b>Enable</b> or <b>Disable</b> for the metafile Spooling.
Print Optimizations*	Select <b>Disable</b> when the printer does not use the device fonts and select <b>Enable</b> when the printer uses the device fonts.

\* See Windows Help for more information.

## ***Defining a custom paper size***

If your paper is not included in the Paper Size drop-down list, you can add the size to the list.

### **For Windows 98 and Me:**

Click Custom or User Defined Size and enter the paper size in the window that appears.

### **For Windows 2000, XP, and NT 4.0:**

1. For Windows 2000 or NT, click Start > Settings > Printers.

For Windows XP Professional, click Start > Settings > Printers and Faxes.

For Windows XP Home Edition, click Start > Printers and Faxes.

2. Click the EPSON LX-300+II ESC/P icon.
3. Select Server Properties from the file menu.
4. Select Create a New Form.
5. Enter the paper size in the Measurement fields.
6. Click Save Form and then click OK.



## Monitoring settings

Setting	Explanation
EPSON Status Monitor 3	You can access EPSON Status Monitor 3 when you click this button. To monitor the printer, make sure the Monitor the printing status check box is selected.
Monitoring Preferences	Click this button to open the Monitoring Preferences window, where you can make settings for EPSON Status Monitor 3. See "Setting up EPSON Status Monitor 3" on page 42 for more information.

---

## Using EPSON Status Monitor 3

EPSON Status Monitor 3 allows you to monitor your printer's status, alerts you when printer errors occur, and provides troubleshooting instructions when needed. It is available when:

- The printer is connected directly to the host computer via the parallel port [LPT1] or the USB port, and
- Your system is configured to support bidirectional communication.

Status Monitor 3 is installed when you install the printer driver (as described in the *User's Guide*). When sharing the printer, be sure to set Status Monitor 3 so that the shared printer can be monitored on the printer server. See "Setting up EPSON Status Monitor 3" on page 42 and "Setting up the printer server" on page 45.

## Setting up EPSON Status Monitor 3

Follow these steps to set up Status Monitor 3:

1. Open the printer driver and select the Utility menu.
2. Click the Monitoring Preferences button. You see the Monitoring Preferences window:



3. The following settings are available:

Setting	Explanation
Select Notification	Click on the <b>Error</b> and <b>Communication Error</b> check boxes to turn notification on or off.
Select Shortcut Icon	The selected icon is displayed on the taskbar (shown in the example box). Click the <b>Shortcut Icon</b> check box for easy access to the Monitoring Preferences window.
Receive error notification for shared printers	When this box is checked, you'll receive notification of an error on a shared printer.
Allows monitoring of shared printers	When this box is checked, a shared printer can be monitored by other PCs.

**Note:**

Click the *Default* button to restore all items to their default settings.

## Accessing EPSON Status Monitor 3

Do either of the following to access EPSON Status Monitor 3:

- Double-click the printer shortcut icon on the taskbar. (To add a shortcut icon, go to the Utility menu and follow the instructions.)
- Open the Utility menu and click the EPSON Status Monitor 3 icon.

You see the following printer status window:



## ***Installing EPSON Status Monitor 3***

If you need to install Status Monitor 3, you can either download it from Epson's web site; or if you have the Printer Software CD-ROM, you can follow these steps:

1. Make sure the printer is off and Windows is running on your computer.
2. Insert the Printer Software CD-ROM in the CD-ROM or DVD drive. After a moment, you see the EPSON Installation Program screen.
3. Close the Installation Program window.
4. Open the CD-ROM folder and double-click the ENGLISH folder.
5. Double-click STM3 and then STMSETUP.EXE.
6. Make sure the EPSON LX-300+II icon is selected and click OK.

The Status Monitor 3 files are installed.

---

## Setting Up Your Printer on a Network

If the printer will be shared over a standard Windows network, follow the instructions in this section to set up the printer server and client computers.

The computer that is directly connected to the printer is the printer server, and the other computers are the clients which need permission to share the printer with the printer server.

**Note:**

- ❑ *When sharing the printer, be sure to set EPSON Status Monitor 3 so that the shared printer can be monitored on the printer server. See "Setting up EPSON Status Monitor 3" on page 42.*
- ❑ *When you are using a shared printer in Windows 98 or Me, on the server, double-click the Network icon in the Control panel and make sure that the "File and printer sharing for Microsoft Networks" component is installed. Then, on the server and clients, make sure that the "IPX/SPX-compatible Protocol" or the "TCP/IP Protocol" is installed.*
- ❑ *The printer server and clients should be set on the same network system, and they should be under the same network management beforehand.*

### Setting up the printer server

To set up the printer server, follow the steps in the appropriate section below:

- ❑ For Windows 98 or Me, see the following section.
- ❑ For Windows 2000, XP, or NT, see page 47.

## Windows 98 or Me

Follow these steps to set up the printer server in Windows 98 or Me:

1. Click Start > Settings > Control Panel.
2. Double-click the Network icon.
3. Click the File and Print Sharing button on the Configuration menu.
4. Select the I want to be able to allow others to print to my printer(s) check box, then click OK.
5. Click OK to accept the settings.
6. When prompted, restart the computer and continue with the settings.
7. Select Printers from the Control Panel menu.
8. Right-click the LX-300+II icon, and select Sharing from the menu.
9. Select Shared As, type the name in the Share Name box, and click OK. Type a Comment and Password if needed.



**Note:**

- ❑ *Do not use spaces or hyphens for the share name, or an error may occur.*
- ❑ *When sharing the printer, be sure to set EPSON Status Monitor 3 so that the shared printer can be monitored on the server. See “Setting up EPSON Status Monitor 3” on page 42.*

10. Follow the instructions on page 49 to set up the client computers so they can use the printer on a network.

### **Windows 2000, XP, or NT 4.0**

Follow the steps below to set up the printer server in Windows 2000, XP, or NT.

**Note:**

*You must access Windows 2000, XP, or NT as the Administrators of the local machine.*

1. In Windows 2000 or NT, click Start > Settings > Printers.

In Windows XP Professional, click Start > Settings > Printers and Faxes.

In Windows XP Home Edition, click Start > Printers and Faxes.

2. Right-click your printer icon, and click Sharing from the menu.

If you see the following message in Windows XP, click either Network Setup Wizard or If you understand the security risks but want to share printers without running the wizard, click here.

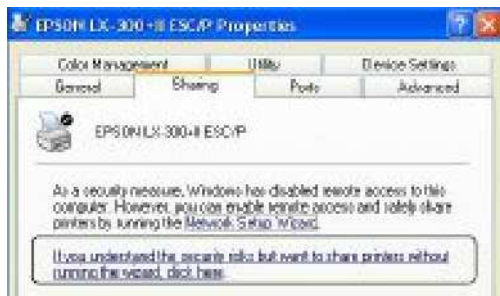

In either case, follow the on-screen instructions.

3. In Windows 2000, select Shared as. In Windows NT, select Shared. Then type the name in the Share name box and click OK.

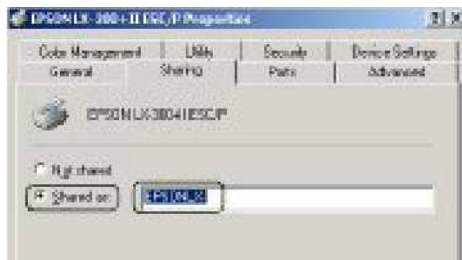



In Windows XP, select Share this printer, then type the name in the Share name box and click OK.



**Note:**

*Do not use spaces or hyphens for the share name.*

Follow the instructions on page 49 to set up the client computers so they can use the printer on a network.

## **Setting up the clients**

This section describes how to install the printer driver on the client computers by accessing the shared printer on a network. Follow the instructions for your operating system:

- Windows 98 or Me: see page 50.
- Windows 2000 or XP: see page 52.
- Windows NT 4.0: see page 55.

**Note:**

- ❑ *This section describes how to access the shared printer on a standard network system using the server (Microsoft workgroup). If you cannot access the shared printer due to the network system, ask your network administrator for assistance.*
- ❑ *This section describes how to install the printer driver by accessing the shared printer from the Printers folder. You can also access the shared printer from Network Neighborhood or My Network on the Windows desktop.*
- ❑ *If you want to be able to use Status Monitor 3 on the clients, you need to install both the printer driver and Status Monitor 3 on each client from the CD-ROM.*

## **Windows 98 or Me**

Follow these steps to set up Windows 98 or Me clients:

1. Click Start > Settings > Printers.
2. Double-click the Add Printer icon, then click Next.
3. Select Network printer, then click Next.
4. Click Browse.

**Note:**

*You can also type “\\(the name of the computer that is locally connected to the shared printer)\(the shared printer’s name)” in the Network path or queue name.*

5. Click the computer or server that is connected to the shared printer, and the name of the shared printer. Then click OK.



**Note:**

*The name of the shared printer may be changed by the computer or server it is connected to. If you're not sure about the shared printer's name, ask the network administrator.*

6. Click Next.

If the printer driver was installed on the client previously, you need to select the new printer driver or the current printer driver when you are prompted.

If the operating system on the printer server is Windows 98 or Me, go to the next step.

If the operating system on the printer server is not Windows 98 or Me, go to "Installing the printer driver from the CD-ROM" on page 57.

7. Check the name of the shared printer, and select whether to use it as the default printer. Click OK, and then follow the on-screen instructions.

**Note:**

You can change the shared printer's name so that it appears only on the client computer.

## Windows 2000 or XP

Follow the steps below to set up clients in Windows 2000 or XP.

**Note:**

You can install the driver of the shared printer if you have Power Users or more powerful access rights, even if you are not the Administrator.

1. For Windows 2000 clients, click Start > Settings > Printers.

For Windows XP Professional clients, click Start > Settings > Printers and Faxes.

For Windows XP Home Edition clients, click Start > Printers and Faxes.

2. For Windows 2000, double-click the Add Printer icon, then click Next.

For Windows XP, click Add a printer in the Printer Tasks menu and click Next.



3. Select Network printer (for Windows 2000) or A network printer, or a printer attached to another computer (for Windows XP), then click Next.
4. For Windows 2000, select Type the printer name, or click Next to browse for a printer, then click Next.

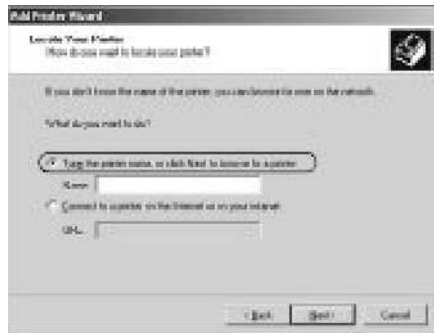

**Note:**

*You can also type the shared printer's name or network path in the Name box, such as "\\(the name of the computer that is locally connected to the shared printer)\(the shared printer's name)."*

For Windows XP, select Browse for a printer, then click Next.



5. Click the icon of the computer or server that is connected to the shared printer, and the name of the shared printer. Then click Next.



**Note:**

- The name of the shared printer may be changed by the computer or server that is connected to the shared printer. To check the name of the shared printer, ask the network administrator.
- If the printer driver was installed on the client previously, you need to select either the new printer driver or the current printer driver when prompted.
- If the operating system on the printer server is Windows 2000 or XP, go to the next step.
- If the operating system on the printer server is Windows 98, Me, or NT, you'll need to install the printer driver from the CD-ROM. See page 57.

6. For Windows 2000, select whether to use the printer as the default printer, then click OK.

For Windows XP, if another driver is already installed, select whether to use the printer as the default printer, then click OK.

7. Check the settings, then click Finish.



## **Windows NT 4.0**

Follow the steps below to set up Windows NT 4.0 clients.

**Note:**

*You can install the driver of the shared printer if you have Power Users or more powerful access rights, even if you are not the Administrator.*

1. Click Start > Settings > Printers.
2. Double-click the Add Printer icon.
3. Select Network printer server, then click Next.

- Click the icon of the computer or server that is connected to the shared printer and the name of the shared printer. Then click OK.



**Note:**

- You can also type “\\(the name of the computer that is locally connected to the shared printer)\(the shared printer’s name)” in Network path or queue name.
  - The name of the shared printer may be changed by the computer or server that is connected to it. To check the name of the shared printer, ask the network administrator.
  - If the printer driver was installed on the client previously, you need to select the new printer driver or the current printer driver when prompted.
  - If the operating system on the printer server is Windows NT, go to the next step. If it is not Windows NT, go to “Installing the printer driver from the CD-ROM” on page 57.
- Select whether to use the printer as the default printer, then click OK.
  - Click Finish.



## ***Installing the printer driver from the CD-ROM***

This section describes how to install the printer driver on the clients when the server and clients use different operating systems.

**Note:**

*When installing on Windows 2000, XP, or NT clients, you must access Windows as the Administrator.*

1. Access the shared printer. When you see the prompt, click OK, and follow the on-screen instructions to install the printer driver from the CD-ROM.
2. Insert the CD-ROM. When you see the EPSON Installation Program screen, click Cancel. Then type the appropriate drive and folder names in which the printer driver for clients is located, and click OK.

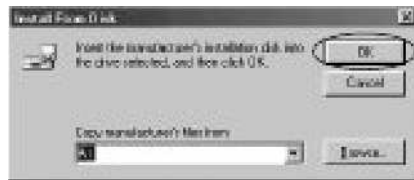

When installing drivers in Windows 2000 or XP, “Digital Signature is not found” may appear. Click Yes (for Windows 2000) or Continue Anyway (for Windows XP) and continue installing.

The folder name depends on which operating system is being used.

Client's OS	Folder Name
Windows 98	\<Language>\WIN98
Windows Me	\<Language>\WINME
Windows 2000 or XP	\<Language>\WIN2000
Windows NT 4.0	\<Language>\WINNT40

3. Select the name of the printer, and click OK. Then follow the on-screen instructions.

**Note:**

*If you also want to install EPSON Status Monitor 3, see page 44 for instructions.*

---

## Canceling Printing

If you need to cancel a print job, follow these steps:

1. Double-click the printer icon on the task bar:



2. To cancel printing for a single document, choose the document and select Cancel Printing (Windows 98 or Me) or Cancel (Windows 2000, XP, or NT) on the Document menu.

To cancel printing of all documents, select Purge Print Documents (Windows 98 or Me) or Cancel All Documents (Windows 2000, XP, or NT) on the Printer menu.



---

## ***Uninstalling the Printer Software***

If you need to reinstall or upgrade the printer driver, first uninstall the current printer driver.

### ***Uninstalling the printer driver and EPSON Status Monitor 3***

1. Quit all applications.
2. Click Start > Control Panel or Start > Settings > Control Panel.
3. Double-click the Add/Remove Programs icon.



4. Select EPSON Printer Software, and click Add/Remove or Change/Remove.

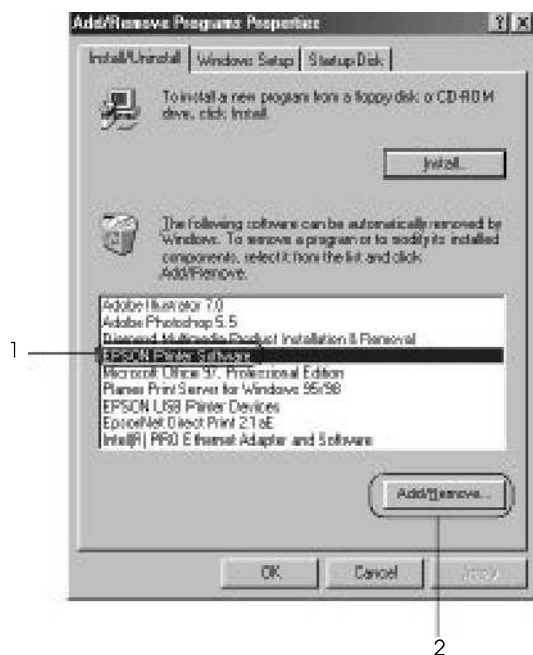

5. On the Printer Model tab, select the LX-300+II icon, and click OK.

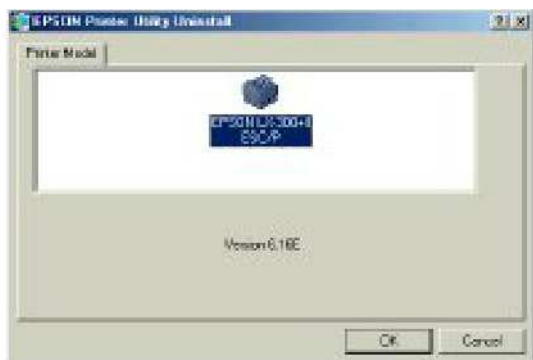

6. If you need to uninstall Monitored Printers, click Yes in the displayed dialog box.

**Note:**

*You can uninstall only the Monitored Printers utility of EPSON Status Monitor 3. When the utility is uninstalled, you cannot change the setting of Monitored Printers from Status Monitor 3.*

7. If you want to uninstall EPSON Status Monitor 3, click Yes in the window that appears.
8. Follow the on-screen instructions.

### **Uninstalling the USB device driver**

If the printer is connected to your computer with a USB interface cable, you also need to uninstall the USB device driver.

**Note:**

- Uninstall the printer driver before uninstalling the USB device driver.*
- Once you have uninstalled the USB device driver, you cannot access any other Epson printers connected with a USB interface cable.*

Follow these steps to uninstall the USB device driver:

1. Follow steps 1 through 3 on page 59.

2. Select EPSON USB Printer Devices, and click Add/Remove.

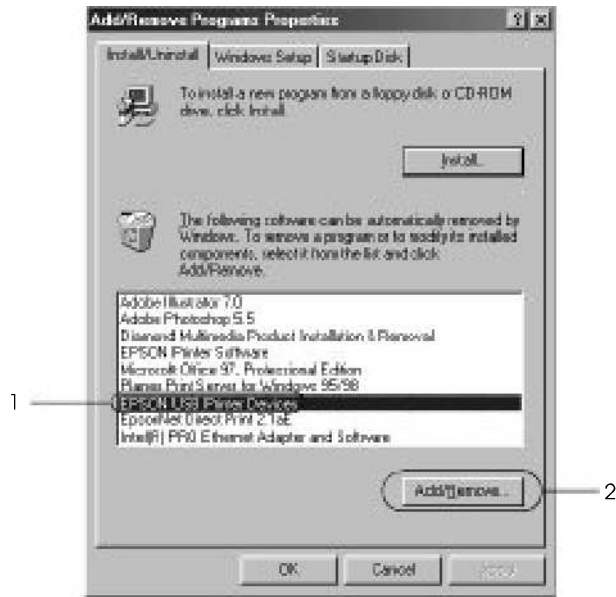

**Note:**

- ❑ *EPSON USB Printer Devices appears only in Windows 98 or Me when the printer is connected to the computer with a USB interface cable.*
- ❑ *If the USB device driver is not installed correctly, EPSON USB Printer Devices may not appear. In this case, you need to run the "Epusbun.exe" file on the CD-ROM. Insert the Printer Software CD-ROM, access the CD-ROM drive, and open the \<Language>\WIN98 or \<Language>\WINME folder. Then double-click Epusbun.exe.*

3. Follow the on-screen instructions.

Now see the *User's Guide* to install the printer driver.

## Using the Control Panel

The buttons and lights on the control panel let you:

- Adjust line and form feeding
- Load and eject paper
- Select a built-in font
- Change the printer's default settings

### Control Panel Buttons and Lights

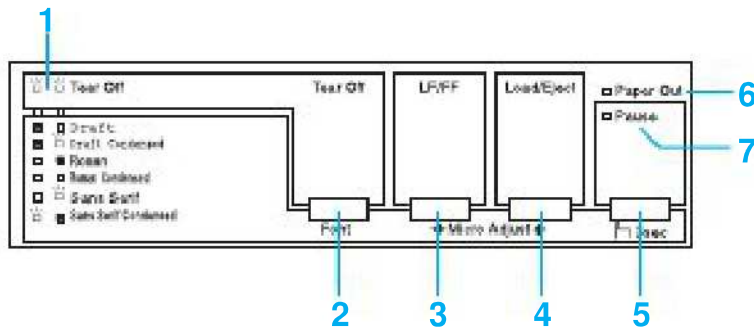

#### 1 Tear Off (Font) lights

Flash when continuous paper is in the tear-off position; otherwise, the lights indicate the selected font.

## 2 Tear Off (Font) button

- Advances continuous paper to the tear-off position.
- Feeds continuous paper backward from the tear-off position to the top-of-form position.
- In Micro Adjust mode, selects one of the six built-in fonts.

## 3 LF/FF button

- Feeds paper line by line when pressed and released.
- Ejects a single sheet or advances continuous paper to the next top-of-form position when held down.
- In Micro Adjust mode, adjusts the top-of-form and tear-off position.

## 4 Load/Eject button

- Loads a single sheet of paper.
- Ejects a single sheet of paper.
- Loads continuous paper from the standby position.
- Feeds continuous paper backward to the standby position.
- In Micro Adjust mode, adjust the top-of-form and tear-off position.

## 5 Pause button

Stops printing temporarily, and resumes printing when pressed again. When held down for three seconds, turns on Micro Adjust mode. To turn it off, press it again.



## 6 Paper Out light

- On when no paper is loaded in the selected paper source or when paper is not loaded correctly.
- Flashes when paper has not been fully ejected or a paper jam has occurred.

## 7 Pause light

- On when the printer is paused.
- Flashes when the printer is in Micro Adjust mode.
- Flashes when the print head has overheated.

## **Selecting a built-in font**

Usually you use your software application to select the font you want to use in a document. However, you can also select one of these built-in fonts using the buttons on the printer's control panel:

- Draft
- Draft Condensed
- Roman
- Roman Condensed
- Sans Serif
- Sans Serif Condensed

Follow these steps to use the control panel to select a built-in font:

1. Make sure the printer is on but not printing. If it is, wait until it stops.
2. Hold down the Pause button for three seconds to enter Micro Adjust mode. The Pause light begins to flash and the two Tear Off (Font) lights show the current font selection.
3. Press the Tear Off (Font) button repeatedly to cycle through the fonts, and stop when the lights on the control panel indicate the font you want. Your selection stays in effect until you change it again.

**Note:**

*Settings you make in your application programs usually override settings you make from the printer's control panel. For best results, use your application to select a font.*

*Bar code fonts cannot be selected from the control panel.*

---

## Changing the Default Settings

The default settings control many printer functions. While you can often set these functions through your software or printer driver, you may sometimes need to change a default setting from the printer's control panel using the Default Setting mode.

The following table lists the default settings and the options you can select in Default Setting mode. The settings are explained in detail after the table. For instructions on using Default Setting mode, see page 72.

Settings	Options
Page length for tractor	Length in inches: 3, 3.5, 4, 5.5, 6, 7, 8, 8.5, <b>11</b> , 70/6, 12, 14, 17
Skip over perforation	On, <b>Off</b>
Auto tear off	On, <b>Off</b>
Auto line feed	On, <b>Off</b>
Print direction	<b>Bi-D</b> , Uni-D
Software	<b>ESC/P</b> , IBM 2380 Plus
0 slash	On, <b>Off</b>
High speed draft	<b>On</b> , Off
I/F mode	<b>Auto</b> , Parallel, Serial, USB
Auto I/F wait time	<b>10 seconds</b> , 30 seconds
Baud rate	<b>19200</b> , 9600, 4800, 2400, 1200, 600, 300 BPS
Parity	<b>None</b> , Odd, Even, Ignore
Data length	<b>8 bit</b> , 7 bit
Parallel I/F bidirectional mode	<b>On</b> , Off
Packet mode	<b>Auto</b> , Off

Settings	Options
Character table	Standard model: Italic, <b>PC 437</b> , PC 850, PC 860, PC 863, PC 865, PC 861, BRASCII, Abicomp, Roman 8, ISO Latin 1, PC 858, ISO 8859-15  All other models: Italic, PC 437, PC 850, PC 437 Greek, PC 853, PC 855, PC 852, PC 857, PC 866, PC 869, MAZOWIA, Code MJK, ISO 8859-7, ISO Latin 1T, Bulgaria, PC 774, Estonia, ISO 8859-2, PC 866 LAT, PC 866 UKR, PC APTEC, PC 708, PC 720, PC AR864, PC 860, PC 863, PC 865, PC 861, BRASCII, Abicomp, Roman 8, ISO Latin 1, PC 858, ISO 8859-15, PC 771, PC437 Slovenia, PC MC, PC1250, PC1251
International character set for Italic table	<b>Italic U.S.A.</b> , Italic France, Italic Germany, Italic U.K., Italic Denmark1, Italic Sweden, Italic Italy, Italic Spain1
Manual feed wait time	1 second, <b>1.5 seconds</b> , 2 seconds, 3 seconds
Buzzer	<b>On</b> , Off
Auto CR (IBM 2380 Plus)	On, <b>Off</b>
IBM character table	Table1, <b>Table2</b>

### *Page length for tractor*

This setting allows you to set the page length (in inches) for continuous paper.

### *Skip over perforation*

This feature is available only when continuous paper is selected. When you select On, the printer provides a one-inch (25.4 mm) margin between the last line printed on one page and the first line printed on the next page. Because the margin settings in most applications override margin settings made from the control panel, you should use this setting only if you cannot set your top and bottom margins using your application.

### *Auto tear off*

When Auto tear off is on and you are using continuous paper with the push tractor, the printer automatically advances the paper perforation to the tear-off position, where you can easily tear off the printed pages. When the printer receives the next print job, it automatically moves the unused paper back to the top-of-form position and starts printing, so you can use all of the next page.

When Auto tear off is off, you need to move the perforation to the tear-off position by pressing the control panel button. See "Using the Tear Off button" on page 24 for more information.

### *Auto line feed*

When auto line feed is on, the printer accompanies each carriage return (CR) code received with a line feed code, and the print position moves to the next line. If the printer adds an extra line after every carriage return, select Off.

### *Print direction*

You can select bidirectional printing (Bi-D) or unidirectional printing (Uni-D). Printing is normally bidirectional because it is faster. Unidirectional printing, however, allows for precise vertical printing alignment, which is useful for printing graphics.

### *Software*

When you select ESC/P, the printer operates in the EPSON ESC/P mode. When you select IBM 2380 Plus, the printer emulates an IBM printer.

### *O slash*

The zero character has a slash (0/) when this feature is turned on. It has no slash (0) when it is turned off. The slash allows you to easily distinguish between the uppercase letter O and a zero.

### *High speed draft*

When you choose On for High speed draft, the printer prints up to 300 cps (characters per second) at 10 cpi (characters per inch). When you choose Off, the printer prints up to 225 cps at 10 cpi.

### *I/F (interface) mode*

The printer comes with three kinds of interfaces; parallel, serial, and USB.

If your printer is connected to only one computer, choose Parallel, Serial, or USB for the interface mode, depending on the interface you use. If your printer is connected to two computers using different interfaces, select Auto (automatic) to allow the printer to automatically switch between interfaces depending on which one is receiving data.

### *Auto I/F (interface) wait time*

This setting takes effect only when I/F (interface) mode is set to Auto. This setting determines how long the printer waits when it no longer receives data from an interface before it checks whether a print job is being sent through the other interface. You can specify 10 seconds or 30 seconds for the auto interface wait time.

### *Baud rate*

Use this option to set the data transfer rate (baud) for the serial interface. The baud rate is measured in bits per second (bps). See your computer manual and software documentation for the proper setting.

### *Parity*

When this option is set to None, parity checking is disabled. The parity bit, if used, provides a basic form of error detection. See your computer manual and software documentation for the proper setting.

### *Data length*

Set the data length of the serial interface to 7 bit or 8 bit. See your computer manual and software documentation for the proper setting.

### *Parallel I/F bidirectional mode*

The parallel interface bidirectional transfer mode is used when this feature is turned on. If bidirectional transfer mode is unnecessary, turn this off.

### *Packet mode*

Select Auto for Packet mode to print from Windows applications using the printer driver included in the software CD-ROM that comes with the printer. Turn off this mode if you encounter connection problems when you are printing from applications based on other operating systems such as DOS.

### *Character table*

You can select among various character tables.

### *International character set for Italic table*

You can select among several international character sets for the Italic character table. Each character set contains eight characters that vary depending on the country or language, so you can customize the Italic table to suit your printing needs.

### *Manual feed wait time*

This sets the amount of wait time between the time paper is inserted into the paper guide and when it is fed. If the paper feeds before you can adjust its position to your satisfaction, you can increase the wait time.

### *Buzzer (beeper)*

The printer beeps when an error occurs. (See “Using the error indicators” on page 77 for more information on printer errors.) If you do not want the printer to beep when an error occurs, turn this setting off.

### *Auto CR (carriage return)*

This setting is available only in IBM 2380 Plus emulation mode. When Auto CR is on, each line feed (LF) code or ESC J code is accompanied by a carriage return code. This moves the print position to the beginning of the next line.

### *IBM character table*

This setting is available only in IBM 2380 Plus emulation mode. When you select Table 1, hex codes 80H to 90H of the character tables are used for the control codes. When you select Table 2, hex codes 80H to 90H are used for characters.

## **Using Default Setting mode**

Follow the steps below to enter Default Setting mode and change the printer’s default settings.

### **Note:**

- ❑ *To print the language selection instructions and Default Setting mode instructions, you need five sheets of A4 or letter-size paper or five pages of continuous paper that is at least 11 inches (279 mm) long and 8.27 inches (210 mm) wide.*
- ❑ *If you use single sheets without an optional cut-sheet feeder, you need to insert a new sheet of paper each time the printer ejects a printed sheet.*

1. Make sure paper is loaded and the printer is off.



2. Hold down the Tear Off (Font) button and then turn on the printer.

The printer enters Default Setting mode and prints instructions for selecting the language. The current language is indicated by which control panel lights are on. (For English, only the Pause light is on.)

3. If you want a different language, press the LF/FF button until the lights show the language you want.
4. Press the Tear Off (Font) button to print a list of all the current settings.
5. If the settings are all correct, turn off the printer to exit Default Setting mode.

If you want to change any settings, go to step 6.

6. Press the Tear Off (Font) button. The printer prints instructions for changing the settings.
7. Press the LF/FF button to scroll through the options for the selected setting until you see the one you want. Then press the Tear Off (Font) button to select the next setting you want to change.
8. When you finish making settings, turn off the printer to exit Default Setting mode.

Your new settings remain in effect until you change them again or reset the printer's defaults.

## ***Restoring the printer's default settings***

If you want to restore all the factory default settings, turn off the printer. Then hold down the Load/Eject, LF/FF, and Pause buttons while you turn on the printer.

# **Maintenance and Troubleshooting**

This chapter explains how to clean and transport the printer, and provides basic troubleshooting information.

---

## ***Cleaning the Printer***

To keep your printer operating at its best, you should clean it thoroughly several times a year. Follow these steps:

1. Remove any paper loaded in the printer and turn it off.
2. Remove the paper guide. If a pull tractor or an optional cut-sheet feeder is installed, remove it.
3. Use a soft brush to carefully brush away all dust and dirt from the outer case and paper guide.
4. If the outer case or paper guide is still dirty or dusty, clean them with a soft, clean cloth dampened with a mild detergent dissolved in water. Keep the printer cover in place and lower it until it lies flat on the top of the printer to prevent water from getting inside the printer.

**Caution:**

- ❑ *Never use alcohols or thinners to clean the printer; these chemicals can damage the printer components and the case.*
- ❑ *Be careful not to get water onto the printer mechanism or electronic components.*
- ❑ *Do not use a hard or abrasive brush.*
- ❑ *Do not spray the inside of the printer with lubricants; unsuitable lubricants can damage the printer mechanism.*

---

## **Transporting the Printer**

If you need to transport your printer for some distance, carefully repack it using the original box and packing materials or equivalent packaging.

**Warning:**

- ❑ *When transporting the printer, do not lift it by the USB cable holder as the holder may detach and cause the printer to fall. Hold the bottom left and right sides of the printer firmly to lift it.*
  - ❑ *You need to move the print head by hand to remove the ribbon cartridge. If you have just used the printer, the print head may be hot; let it cool for a few minutes before touching it.*
1. Remove any paper loaded in the printer. Make sure the printer is turned off.
  2. Unplug the power cord from the electrical outlet; then disconnect the interface cable from the printer.
  3. Remove the paper guide, the USB cable holder, paper supports, and knob.

4. Make sure the tractor that comes with your printer is installed in the push position.
5. If an additional pull tractor is installed, remove it. If any options are installed, remove them and pack them in their original boxes.
6. Make sure the print head is not hot. Then remove the ribbon cartridge.
7. Repack the printer and all the other items in their original packing materials and place them in the printer's original box.

---

## **Troubleshooting**

You can solve most printing problems by checking for the solutions in this section. It explains:

- How to read the control panel lights that indicate errors (page 77)
- Problems and solutions (page 79)
- Clearing paper jams (page 93)
- Printing a self test (page 94)
- Where to get help if you need assistance from Epson (page 96)

## Using the error indicators

If your printer stops working and one or more control panel lights are on or flashing or the printer beeps, use the following table to diagnose and fix the problem. If you cannot fix your problem using this table, go to the next section.

Panel light state	Beep pattern	Problem
		Solution
☐ Pause	–	The printer is paused.
		Press the <b>Pause</b> button to resume printing.
☐ Pause	•••	Paper from another paper source is currently in the paper path.
		Move the paper release lever to the correct position and press the <b>Load/Eject</b> button to clear the paper from the paper path. Then set the lever to the position you want to use. Press the <b>Pause</b> button to turn off the Pause light, if necessary.
☐ Paper Out ☐ Pause	•••	No paper is loaded in the selected paper source.
		Load paper in the printer. Then press the <b>Pause</b> button to turn off the Pause light, if necessary.
	•••	The paper is not loaded correctly.
		Remove your paper and reload it. Then press the <b>Pause</b> button to turn off the Pause light, if necessary.
•••	Paper is jammed in the printer.	
	Turn off the printer and open the printer cover, tear off the paper supply, and turn the paper feed knob to eject the remaining paper.	

Panel light state	Beep pattern	Problem
		Solution
<input type="checkbox"/> Paper Out <input type="checkbox"/> Pause	•••	<p>Continuous paper is not fed back to the standby position.</p> <p>Tear off the printed document at the perforation; then press the <b>Load/Eject</b> button. The printer feeds the paper to the standby position. Press the <b>Pause</b> button to turn off the Pause light, if necessary.</p>
	•••	<p>A single sheet of paper is not fully ejected.</p> <p>Press the <b>Load/Eject</b> button to eject the sheet. Then press the <b>Pause</b> button to turn off the Pause light, if necessary.</p>
	•••	<p>Paper is jammed in the printer.</p> <p>Clear the paper jam as described on page 93.</p>
<input type="checkbox"/> Pause	–	<p>The print head is overheated.</p> <p>Wait a few minutes; the printer resumes printing automatically once the print head has cooled.</p>
<input type="checkbox"/> All the lights on the control panel	•••••	<p>An unknown printer error has occurred.</p>
		<p>Turn off the printer and leave it off for several minutes; then turn on the printer again. If the error recurs, contact your dealer.</p>

= on,  = flashing

••• = short series of beeps (three beeps)

••••• = long series of beeps (five beeps)

**Note:**

*The printer beeps once if you press a control panel button when the corresponding function is not available.*

## Problems and solutions

Most problems you may encounter while operating your printer have simple solutions.

You can check the operation of your printer using the self test. (See page 94.) If the self test works properly the problem is probably caused by the computer, the application software, or the interface cable. If the self test does not work, see “Where To Get Help” on page 96.

**Note:**

*If you are an experienced user or a programmer, you can print a hexadecimal dump to isolate communication problems between the printer and computer. To print a hex dump, turn off the printer. Next, hold down the Load/Eject and LF/FF buttons while you turn on the printer. Then send data from your computer. The printer prints all the codes it receives in hexadecimal format.*

### Power Supply

#### Power is not being supplied

The lights on the control panel do not come on.	
Cause	What to do
The power cord may be unplugged.	Check that the power cord is properly plugged into the electrical outlet.
The outlet may not be operating.	If the electrical outlet is controlled by an outside switch or automatic timer, use a different outlet. Plug another electrical device, such as a lamp, into the outlet to determine whether the outlet is operating properly.

**The lights come on briefly and then go off. The lights stay off even when the power is turned on again.**

Cause	What to do
The voltage ratings of the printer and electrical outlet may not match.	Check that the printer's voltage rating matches the voltage of your electrical outlet. If the voltages do not match, unplug the printer and contact your dealer immediately. Do not reconnect the power cord to an electrical outlet.

## **Printing**

### **The printer does not print**

**The PAUSE light is off but nothing is printed.**

Cause	What to do
The software may not be installed properly.	Check that the software is installed properly for your printer, as described in the <i>User's Guide</i> .
The interface cable may not match the specifications of the printer or computer.	Check both ends of the interface cable. Make sure the cable meets both the printer and computer specifications.
The printer port may not be set correctly.	For Windows 98, Me, 2000, or NT 4.0, click Start > Settings > Printers. For Windows XP, click Start > Control Panel > Printers and Faxes (or Start > Printers and Faxes). Right-click the LX-300+II printer icon and select Properties. Then, click the Ports or Details tab and select the appropriate port.



**The Paper Out and Pause lights are on and the printer beeps three times.**

Cause	What to do
No paper is loaded.	Load paper in the printer.

**The printer sounds like it is printing, but nothing is printed.**

Cause	What to do
The ribbon cartridge may not be installed properly or the ribbon may be worn out.	See "Replacing the Ribbon Cartridge" on page 105.

**The printer makes a strange noise, beeps five times, and stops printing abruptly.**

Cause	What to do
The paper or ribbon may be jammed.	Turn off the printer and check for a paper jam or a ribbon jam.
The printer may have overheated.	Let the printer cool. Then try to print again. If it still does not print correctly, see "Where To Get Help" on page 96.

**The printer beeps five times and all the lights flash.**

Cause	What to do
An error has occurred.	Turn off the printer and turn it on again. If the problem persists, check for a paper jam or ribbon jam. (If an error occurs when you switch between single sheets and continuous paper, make sure the paper release lever is set correctly.)

## ***The print is faint or uneven***

### **Parts of printed characters are missing at the bottom.**

<b>Cause</b>	<b>What to do</b>
The ribbon cartridge may not be installed properly.	See "Replacing the Ribbon Cartridge" on page 105.

### **The printout is faint.**

<b>Cause</b>	<b>What to do</b>
The ribbon may be worn out.	Replace the ribbon cartridge as described on page 105.

## ***Dots are missing in printed characters or graphics***

### **A line of dots is missing in the printout.**

<b>Cause</b>	<b>What to do</b>
The print head is damaged.	Stop printing and contact Epson to have the print head replaced. See "Where To Get Help" on page 96.

### **Dots are missing in random positions.**

<b>Cause</b>	<b>What to do</b>
Either there is too much slack in the ribbon or the ribbon has come loose.	Reinstall the ribbon cartridge as described on page 105.

### ***Printed characters are not what you expected***

#### **The timesteps or characters you sent with your software did not print.**

<b>Cause</b>	<b>What to do</b>
The software may not be properly configured.	Check that the software is correctly configured for your printer.

#### **The font selected on the control panel does not print.**

<b>Cause</b>	<b>What to do</b>
Your software may be overriding your control panel setting.	Check the font setting in your application software.

### ***The print position is not what you expected***

#### **Printing starts too high or too low on the page, or the bottom part of one page is printed at the top of the next page.**

<b>Cause</b>	<b>What to do</b>
Your application software settings may be incorrect.	Check the margin or top-of-form position setting in your application software.

#### **Page length does not match the length of the paper.**

<b>Cause</b>	<b>What to do</b>
The page length setting in your application may be incorrect.	Check the page length set by your application software and adjust it if necessary.

---

The printer's page length setting may not match the size of the continuous paper you are using.	Check the Page length for tractor setting in Default Setting mode. See page 68.
---	---

**Regular gaps occur in the printout.**

Cause	What to do
One-inch skip-over-perforation may be set.	Set skip-over-perforation to Off in Default Setting mode. See page 67.

## ***Paper Handling***

### ***Single sheets do not feed properly***

**Paper does not feed.**

Cause	What to do
Continuous paper may be left in the printer.	Remove the continuous paper. Set the paper release lever to the single-sheet position. Insert a new sheet.
The paper on the paper guide is positioned too far to the left or right for the printer to detect it.	Move the paper (and the edge guides) a little to the left or right.

### **Paper feeding is crooked or the paper jams.**

<b>Cause</b>	<b>What to do</b>
The paper was not fed correctly or is the wrong type.	Turn off the printer and pull out the paper. Insert a new sheet straight into the paper guide. Make sure you're using the right type of paper. See the paper specifications on page 115.

### **Paper does not eject completely.**

<b>Cause</b>	<b>What to do</b>
The paper may be too long.	Press the LF/FF button to eject the page. Use paper that is within the specified range. See the paper specifications on page 115.

### ***Continuous paper does not feed properly***

#### **The tractor does not feed the paper.**

<b>Cause</b>	<b>What to do</b>
The paper release lever may be in the wrong position.	Check that the paper release lever is pulled forward to the continuous-paper position.
The paper may have come off the tractor.	Reattach the paper to the tractor.

### **Paper feeding is crooked or the paper jams.**

<b>Cause</b>	<b>What to do</b>
The paper supply is obstructed.	Make sure the paper supply is not obstructed by a cable or some other object.
The paper supply is too far away from the printer.	Make sure that your paper supply is within 3 feet (1 meter) of the printer.
The printer cover may be opened.	Close the printer cover.
The edge guide positions may be incorrect.	Position the edge guides at the diamond-shaped guide marks.
The holes on the sides of the paper are misaligned.	Check that the holes on each side of the paper are aligned with each other. Also make sure the sprockets are locked and their covers are closed.
Your paper may be the wrong size or thickness for the printer.	Make sure that the paper size and thickness are within the specified ranges. See page 115 for continuous paper specifications.
When you use side-crimped multipart forms, the copies may not align with the original.	Raise the paper guide to keep the printing position accurate.

### **The paper does not eject properly.**

<b>Cause</b>	<b>What to do</b>
The page may be too long.	Tear off the fresh supply of paper and eject the page from the printer. Use only paper that is within the specified length range. See page 115.

**When you switch between single sheets and continuous paper, the printer beeps three times and the PAUSE light comes on.**

Cause	What to do
You may have tried to change the paper release lever position while paper remained in the printer.	Return the paper release lever to the previous position and eject the paper. Then change the paper release lever position.

## **Options**

***When you use the cut-sheet feeder, the paper does not feed properly***

**The paper does not feed.**

Cause	What to do
The cut-sheet feeder may be incorrectly installed.	Reinstall it as described on page 98.
The paper release lever may be in the wrong position.	Check that the paper release lever is pushed back to the single-sheet position.
You may have loaded too many sheets in the bin.	Remove some sheets.
Paper may be jammed near the print head.	Look for a paper jam.
The edge guide positions may be incorrect.	Position the edge guides at the diamond-shaped guide marks.
There may be only one sheet left in the bin.	Add more paper.

### **Two or more sheets feed at one time.**

<b>Cause</b>	<b>What to do</b>
You may have loaded too many sheets in the bin.	Remove some sheets.
You may not have fanned the stack of paper before loading it into the bin.	Remove the paper, fan the stack to separate the sheets, and reload it in the bin.

### **The paper feeds in crooked.**

<b>Cause</b>	<b>What to do</b>
The right and left paper guides are too far apart.	Position the paper guides to match the width of your paper.
The paper may be old or creased.	Use only new, clean sheets of paper.
There may be too much paper in the stacker.	Remove some sheets.
You may not be using the right type of paper for the cut-sheet feeder. For example, your paper may be too heavy or too light.	Make sure your paper meets the requirements of your printer and cut-sheet feeder. See page 115 for paper specifications.

### **One page of printing has spread to two pages.**

<b>Cause</b>	<b>What to do</b>
Your application software settings may be incorrect.	Check that the page-length setting and lines-per-page setting in your application software are correct.



**Switching between the cut-sheet feeder and the push tractor does not work properly**

**The desired paper type does not load.**

Cause	What to do
The paper release lever may not be in the proper position.	Pull the lever forward to load continuous paper or push the lever back to load single sheets.

**Using the pull tractor with the push tractor, continuous paper does not feed properly**

**Paper is feeding crooked or jams.**

Cause	What to do
The pull tractor and push tractor sprockets are not aligned correctly.	When using both tractors, make sure that the sprockets on both are positioned evenly.
The paper may have too much slack.	Adjust the position of the sprockets to take up any slack along the width of the paper. Remove slack lengthwise by rotating the paper feed knob.
The paper may be caught on the edge guides.	Make sure that the paper guide is installed over the paper and that the edge guides are positioned correctly.

## **Correcting USB Problems**

If you are having difficulty using your printer with a USB connection, read the information in this section.

*Make sure that your computer is a Windows 98, Me, 2000, or XP pre-installed model*

Your computer must be a Windows 98, Me, 2000, or XP pre-installed model. You may not be able to install or run the USB printer driver on a computer that is not equipped with a USB port or that has been upgraded from Windows 95 to Windows 98, Me, 2000, or XP.

*Make sure that EPSON USB Printer Devices appears on the Device Manager menu (in Windows 98 and Me only)*

If you canceled the plug-and-play driver installation before the procedure was complete, either the USB device driver or the printer driver may be incorrectly installed.

Follow these steps to check the installation and reinstall the drivers:

1. Turn the printer on, and plug the USB cable into the printer and the computer.
2. Right-click the My Computer icon on your desktop, then click Properties.
3. Click the Device Manager tab.

If your drivers are correctly installed, EPSON USB Printer Devices should appear on the Device Manager menu.



If EPSON USB Printer Devices does not appear on the Device Manager menu, click the plus (+) sign beside Other devices to view the installed devices.

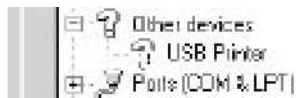

If USB Printer appears under Other devices, the USB printer device driver is not installed correctly.  
If EPSON LX-300+II appears, the printer driver is not installed correctly.

If USB Printer or EPSON LX-300+II does not appear under Other devices, click Refresh or unplug the USB cable from the printer, then plug it into the printer again.

4. Under Other devices, select USB Printer or EPSON LX-300+II and click Remove. Then, click OK.



5. When you see the following window, click OK. Then click OK again to close the System Properties dialog box.



6. Turn off the printer and restart your computer. Then reinstall the drivers from the beginning, following the instructions in the *User's Guide*.

### *Printer does not work correctly with the USB cable*

If your printer does not work correctly with the USB cable, try one or more of these solutions:

- Make sure that the cable you are using is a standard, shielded USB cable.
- If you are using a USB hub, connect the printer to the first tier of the hub, or connect the printer directly to the computer's USB port.
- For Windows 98 or Me, try reinstalling the USB printer device driver and the printer software. First, uninstall EPSON Printer Software using the Add/Remove Programs utility in the Control Panel, then uninstall EPSON USB Printer Devices. Next, reinstall the software as described in the *User's Guide*. If EPSON USB Printer Devices is not registered in the Add/Remove Programs list, access the CD-ROM and double-click epusbun.exe in the \<Language>\WINME or \<Language>\WIN98 folder. Then follow the on-screen instructions.

### **Clearing a paper jam**

If paper becomes jammed in the printer, follow these steps to remove it:

1. Turn off the printer, open or remove the printer cover, and remove the paper guide.
2. If continuous paper is jammed in the printer, tear off the fresh supply at the perforation nearest the paper entry slot.

3. Gently remove any paper inside the printer, including any torn pieces. You can use the knob on the right side of the printer to help feed the paper out.



**Caution:**

*Use the paper feed knob to clear paper jams only when the printer is off. Otherwise, you may damage the printer or change the top-of-form or tear-off position.*

4. Replace the printer cover and paper guide, and turn on the printer. Make sure the Paper Out light is not flashing and the Pause light is off.

## **Printing a self test**

Running the printer's self test helps you determine whether the printer or the computer is causing the problem:

- If the self test results are satisfactory, the printer is working properly and the problem is probably caused by your printer driver settings, application settings, computer, or interface cable. (Be sure to use a shielded interface cable.)
- If the self test does not print properly, there is a problem with the printer. See "Problems and solutions" on page 79 for possible causes and solutions to the problem.

You can print the self test using either single sheets or continuous paper. Be sure to use paper that is at least 8.25 inches (210 mm) wide to run the self test; otherwise, the print head prints directly on the platen.

Follow these steps to perform a self test:

1. Turn off the printer and load continuous or single-sheet paper in the printer.
2. Set the paper release lever to the correct position.



**Caution:**

*Whenever you turn off the printer, wait at least five seconds before turning it back on; otherwise you may damage the printer.*

3. While holding down the LF/FF button or Load/Eject button, turn on the printer.

The self test is printed in Draft characters when the LF/FF button is held, or in NLQ characters when the Load/Eject button is held.

**Note:**

*To temporarily stop the self test, press the Pause button. To resume printing, press the Pause button again.*

4. To end the self test, press the Pause button to stop printing. If paper remains in the printer, press the LF/FF button to eject the printed page. Then turn off the printer.



**Caution:**

*Do not turn off the printer while it is printing the self test. Always press the Pause button to stop printing and the LF/FF button to eject the printed page before you turn off the printer.*

---

## **Where To Get Help**

If your Epson printer is not operating properly and you cannot solve the problem using the troubleshooting information, see the support information below.

### ***Internet support***

Visit Epson's support website at <http://support.epson.com> and select your printer for solutions to common problems. You can download drivers and documentation, get FAQs and troubleshooting advice, or e-mail Epson with your questions.

### ***Speak to a support representative***

Before you call for support, please have the following information ready:

- Product name (Epson LX-300+II)
- Product serial number (located on the back of the printer)
- Proof of purchase (such as a store receipt) and date of purchase
- Computer configuration
- Description of the problem



Then call:

- ❑ U.S.: **(562) 276-4322**, 6 AM to 6 PM, Pacific Time, Monday through Friday.
- ❑ Canada: **(905) 709-2170**, 6 AM to 6 PM, Pacific Time, Monday through Friday.

Toll or long distance charges may apply.

### ***Purchase supplies and accessories***

You can purchase ribbon cartridges and other accessories from an Epson authorized reseller. To find the nearest reseller, call 800-GO-EPSON (800-463-7766). Or you can purchase online at [www.epsonstore.com](http://www.epsonstore.com) (U.S. sales) or [www.epson.ca](http://www.epson.ca) (Canada sales).

### **Options and Consumables**

The following options are available for your LX-300+II:

- Single-bin cut-sheet feeder (C806371)
- Additional tractor (C800301)
- Roll paper holder (#8310)
- Black ribbon cartridge (#8750)

---

### **Cut-sheet Feeder**

The optional single-bin cut-sheet feeder (C806371) handles up to 50 sheets of standard bond paper (22 lb or 82 g/m<sup>2</sup>) without reloading.

Follow these steps to install the cut-sheet feeder:

1. Make sure the printer is turned off. Remove the paper guide and open the printer cover.
2. If the tractor is installed in the pull-tractor position, remove it and reinstall it in the push-tractor position.
3. Make sure the paper release lever is in the single-sheet position.

4. Hold the cut-sheet feeder with both hands and press on the latch levers. Fit the notches in the cut-sheet feeder over the mounting posts on the printer. Releasing the latch levers locks the cut-sheet feeder in place.

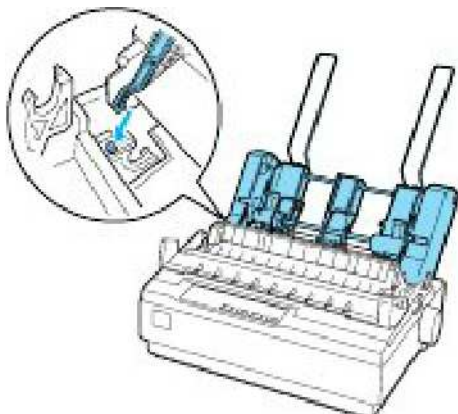

5. Slide the left paper guide so it is aligned with the triangle mark. Then slide the right paper guide to roughly match the width of your paper. Slide the paper support midway between the paper guides.

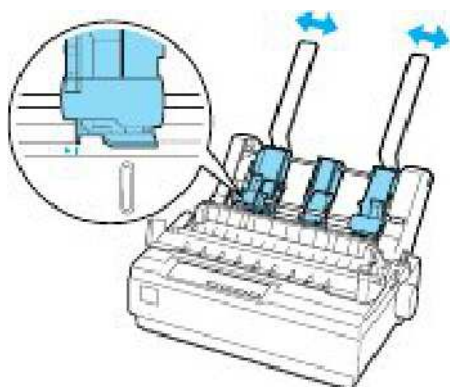

6. Pull the paper set levers all the way forward until the paper guides retract and lock open to allow for paper loading.

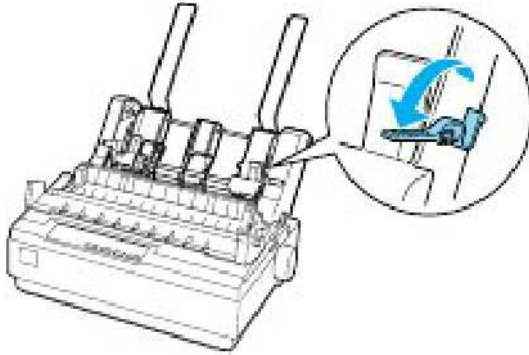

7. Take a stack of paper and fan it. Then tap the side and bottom of the paper on a flat surface to even up the stack.



**Caution:**

*Do not use envelopes, multipart forms, carbon paper, or labels in the cut-sheet feeder.*

8. Insert up to 50 sheets of paper along the left paper guide.
9. Adjust the position of the right paper guide so that it matches your paper's width. Make sure the position of the guide allows the paper to move up and down freely.
10. Push the paper set levers back to clamp the paper against the guide rollers.
11. Remove the paper supports from the edge guides. Insert the two stacker supports supplied with the cut-sheet feeder into the holes on the edge guides.

12. Attach the paper guide to the cut-sheet feeder as shown below.

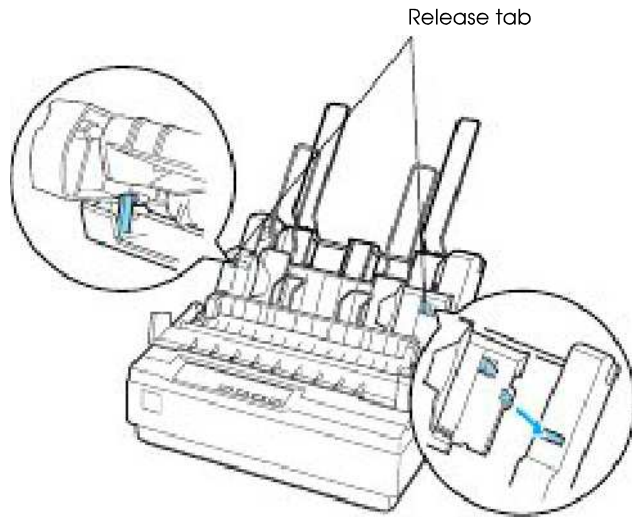

13. Slide the left edge guide to the center until it stops at the guide mark. Then slide the right edge guide to fit the size of paper you will use.

**Note:**

- To remove the paper guide from the cut-sheet feeder, press both release tabs and pull out the paper guide.
- Make sure the printer cover is open when you print.

You can easily switch between continuous paper and cut-sheet feeder paper. See “Switching between continuous paper and single sheets” on page 16 for details.

**Note:**

When you print several pages of continuous paper, fold the first printed page forward at the perforation after the perforation emerges from below the printer cover. This helps the printer feed the printed pages properly and prevents paper jams.

---

## Optional Tractor

You can purchase an additional tractor (C800301) and improve the performance of continuous paper handling by using two tractors at the same time. This is especially useful with continuous pre-printed forms and multipart forms.

Follow these steps to install and load paper on the standard and optional tractor:

1. Turn off the printer.
2. Remove the printer cover and paper guide.
3. Pull the paper release lever forward to the continuous-paper position.
4. Install the first tractor in the push-tractor position.
5. Remove the paper tension unit by squeezing its lock tabs gently and pulling it away from the printer.
6. Lower the pull tractor into the mounting slots at the top of the printer as shown below, until it clicks in place.

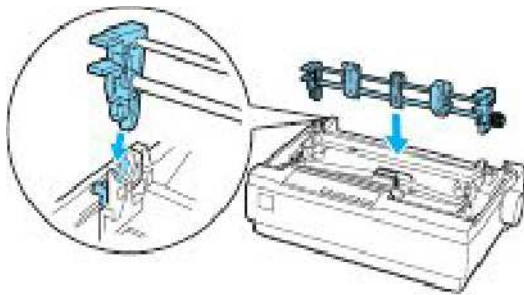

7. Load continuous paper on the push tractor.

8. Turn on the printer. Then hold down the LF/FF button to feed one page.
9. Release the sprocket lock levers on the pull tractor and adjust the sprockets to match the width of the paper you are using. Make sure the sprockets on both tractors are aligned so that the paper is not crooked.
10. Open the sprocket covers. Fit the holes of the paper over the tractor pins and adjust the sprockets as necessary. Close the sprocket covers.
11. If there is slack in the paper between the push and pull tractors, push in and turn the paper feed knob on the right side of the pull tractor to remove the slack.

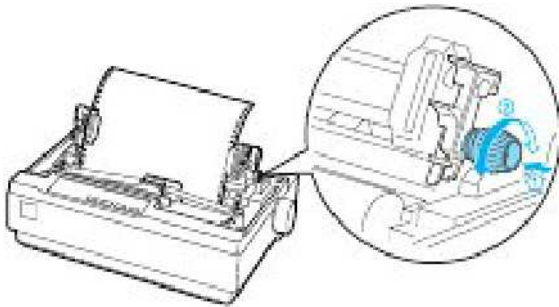

12. Make sure the paper is not crooked or wrinkled and then lock the sprockets in place.
13. Replace the printer cover and the paper guide.

---

## Roll Paper Holder

The optional roll paper holder (#8310) allows you to use your printer with 8.5 inch (216 mm) roll paper. Follow these steps to install and use the roll paper holder:

1. Turn off the printer and remove the paper guide.
2. Position the roll paper holder beneath the printer as shown below. Fit the two holes in the base onto the two positioning pegs on the bottom of the printer.

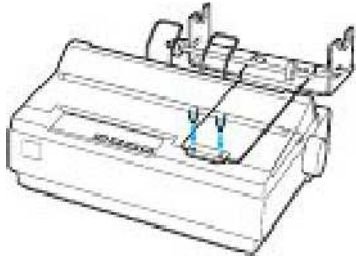

**Caution:**

*Be careful to avoid dropping the roll paper holder when lifting the printer. Only the printer's weight holds it in place.*

3. Push the paper release lever to the single-sheet position.
4. Cut the leading edge of the roll paper straight across. Slide the roll paper holder shaft through the center of the roll.

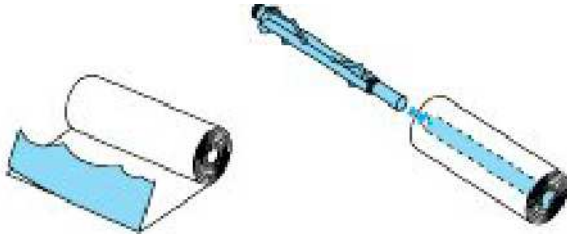



5. Set the shaft and paper roll onto the roll paper holder. Orient the roll so that paper feeds from the bottom of the roll. Then turn on the printer.
6. Bring the leading edge of the paper up over the paper path guide for single sheets and insert it into the printer path for single sheets until you feel resistance.
7. Install the paper guide. Slide the left edge guide to the center until it stops at the guide mark. Then slide the right edge guide to the opposite guide mark.

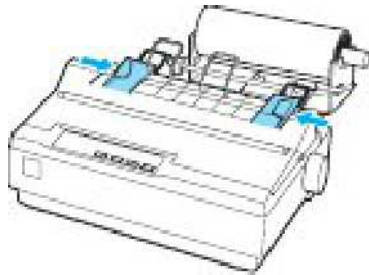

---

## ***Replacing the Ribbon Cartridge***

When printing becomes faint, you need to replace the ribbon cartridge (#8750). Genuine Epson ribbon cartridges are designed and manufactured to work properly with your Epson printer. They ensure proper operation and long life of the print head and other printer parts. Other products not manufactured by Epson may cause damage to your printer, which is not covered by Epson's warranties.

Follow these steps to install or replace the ribbon cartridge:

1. Make sure the printer is turned off.



**Warning:**

*If you have just used the printer, the print head may be hot; let it cool for a few minutes before replacing the ribbon cartridge.*

2. Open the printer cover to the upright position, then pull it up to remove it.

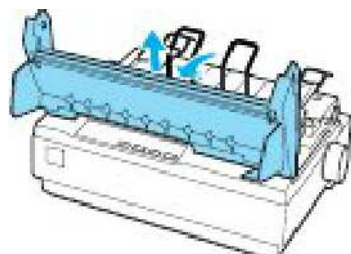

3. Make sure the print head is in the middle of the printer. (If not, make sure it is not hot, then use your hand to slide it to the middle.)
4. Remove the used ribbon cartridge from the printer.
5. Remove the new ribbon cartridge from its package and turn the ribbon-tightening knob in the direction of the arrow to remove any slack from the ribbon so it is easier to install.

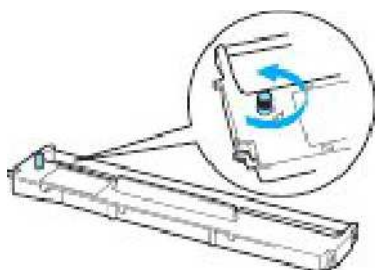

6. Insert the ribbon cartridge into the printer as shown; then press both sides of the cartridge firmly to fit the plastic hooks into the printer slots.

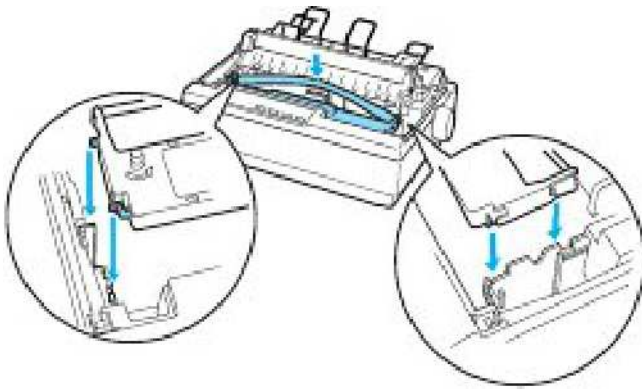

7. Use a pointed object, such as a ball point pen, to guide the ribbon between the print head and ribbon guide.

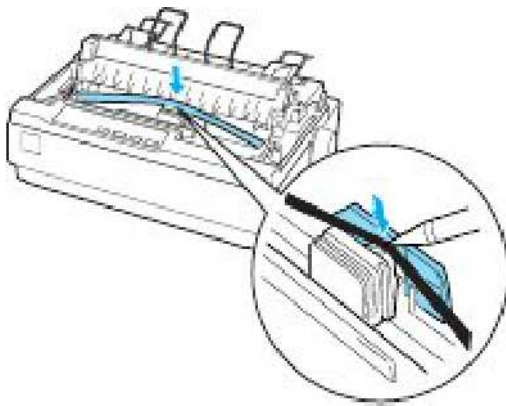

8. Turn the ribbon-tightening knob in the direction of the arrow to help feed the ribbon into place; it should not be twisted or creased.



9. Replace and close the printer cover.

---

## Product Information

This chapter identifies the printer parts and contains detailed specifications.

---

### Printer Parts

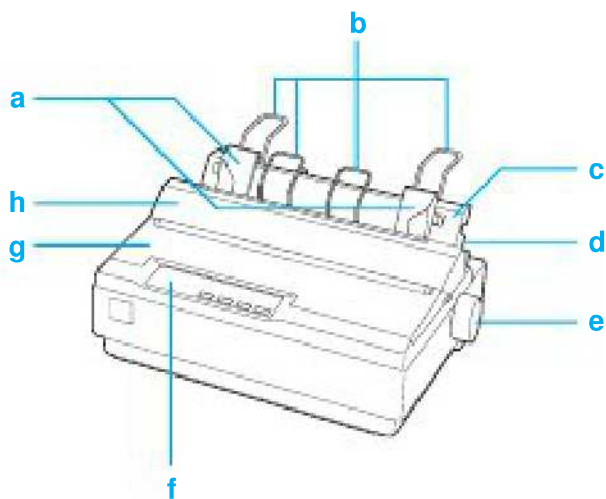

- |                        |                      |
|------------------------|----------------------|
| a. edge guides         | e. knob              |
| b. paper supports      | f. control panel     |
| c. paper guide         | g. printer cover     |
| d. paper release lever | h. paper guide cover |

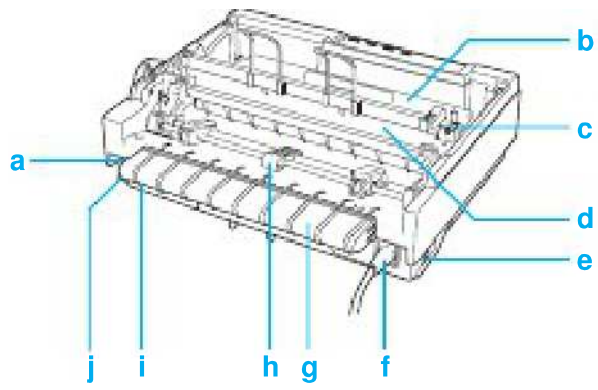

- |                          |                       |
|--------------------------|-----------------------|
| a. serial interface      | b. ribbon cartridge   |
| c. paper thickness lever | d. paper tension unit |
| e. power switch          | f. power cord         |
| g. USB cable holder      | h. tractor            |
| i. USB interface         | j. parallel interface |

---

## Specifications

### Mechanical

Printing method:	9-pin impact dot matrix
Printing speed:	High speed draft 300 cps at 10 cpi 337 cps at 12 cpi 337 cps at 15 cpi  High speed draft 321 cps at 17 cpi condensed 300 cps at 20 cpi  Draft 225 cps at 10 cpi 270 cps at 12 cpi 225 cps at 15 cpi  Draft condensed 191 cps at 17 cpi 225 cps at 20 cpi  Draft emphasized 112 cps at 10 cpi  NLQ 56 cps at 10 cpi 67 cps at 12 cpi 56 cps at 15 cpi 47 cps at 17 cpi 56 cps at 20 cpi
Printing direction:	Bidirectional logic seeking for text and graphics printing. Unidirectional text or graphics printing can be selected using software commands.
Line spacing:	1/6-inch or programmable in 1/216-inch increments
Printable columns:	80 columns (at 10 cpi)
Resolution:	240 × 144 dpi maximum

Feeding method:	Friction feed (rear paper entry) Push tractor feed (rear paper entry) Push and Pull tractor feed (rear paper entry) Pull tractor feed (rear paper entry)	
Feeder:	Rear push tractor Cut-sheet feeder (optional) Pull tractor unit (optional) Roll paper holder (optional)	
Paper feed speed:	Continuous	3.0 inches/second (76 mm/second)
	Intermittent	63 msec/line at 1/6-inch line spacing
Reliability:	Total print volume	12 million lines (except print head) MTBF 6,000 POH (25% duty)
	Print head life	400 million strokes per wire
Dimensions and weight:	Height	6.26 inches (159 mm)
	Width	14.4 inches (366 mm)
	Depth	10.8 inches (275 mm) (excluding the knob, paper release lever, etc.)
	Weight	approx. 9.7 lb (4.4 kg)
Ribbon:	Black ribbon cartridge (#8750)	
	Ribbon life	3 million characters
Acoustic noise:	Approx. 49 db (A) (ISO 7779 pattern)	



## **Electronic**

Interfaces: One standard bidirectional, 8-bit, parallel interface with IEEE-1284 nibble mode support, one EIA-232D serial interface, and one USB (ver1.1) interface

Buffer: 64 KB

Built-in fonts: *Bitmap fonts*  
EPSON Draft 10, 12, 15 cpi  
EPSON Roman 10, 12, 15 cpi, proportional  
EPSON Sans Serif 10, 12, 15 cpi, proportional  
*Bar code fonts*  
EAN-13, EAN-8, Interleaved 2 of 5, UPC-A, UPC-E, Code 39, Code 128, POSTNET

Character tables: One Italic and 12 graphical character tables:  
Italic table,  
PC 437 (US, Standard Europe),  
PC 850 (Multilingual),  
PC 860 (Portuguese),  
PC 861 (Icelandic), PC 865 (Nordic),  
PC 863 (French-Canadian),  
BRASCI, Abicomp, ISO Latin 1,  
Roman 8, PC 858, ISO 8859-15

The following 26 graphical character tables are also available in some countries:  
PC 437 Greek,  
PC 852 (Eastern Europe),  
PC 853 (Turkish), PC 855 (Cyrillic),  
PC 857 (Turkish), PC 866 (Russian),  
PC 869 (Greek),  
MAZOWIA (Poland),  
Code MJK (CSFR),  
ISO 8859-7 (Latin/Greek),  
ISO Latin 1T (Turkish),  
Bulgaria (Bulgarian),  
PC 774 (LST 1283: 1993),  
Estonia (Estonian),  
PC 771 (Lithuanian), ISO 8859-2,  
PC 866 LAT. (Latvian),  
PC 866 UKR (Ukrainian),  
PC APTEC (Arabic), PC 708 (Arabic),  
PC 720 (Arabic), PC AR 864 (Arabic),  
PC437 Slovenia, PC MC, PC1250, PC1251

Character sets: 8 international character sets:  
USA, France, Germany, UK, Denmark I,  
Sweden, Italy, Spain I

## Electrical

	120 V Model	220 to 240 V Model
Input voltage range	AC 99 to 132 V	AC 198 to 264 V
Rated frequency range	50 to 60 Hz	
Input frequency range	49.5 to 60.5 Hz	
Rated current	0.6 A (maximum 1.4 A depending on the character type)	0.3 A (maximum 0.7 A depending on the character type)
Power consumption	Approx. 23 W (ISO/IEC 10561 letter pattern)	

## Environmental

	Temperature (without condensation)	Humidity (without condensation)
Operation	41 to 95 °F (5 to 35 °C)	10 to 80% RH
Storage	-22 to 140 °F (-30 to 60 °C)	0 to 85% RH

## Paper

Use recycled paper, envelopes, labels and single-sheet multipart forms only under normal temperature and humidity conditions, as follows:

- Temperature: 59 to 77 °F (15 to 25 °C)
- Humidity: 30 to 60% RH

Do not load paper that has been folded or is damaged, wrinkled, or curled.

**Single sheets (standard): paper guide and cut-sheet feeder entry**

Width	Paper guide: 3.9 to 10.1 inches (100 to 257 mm) Cut-sheet feeder: 7.2 to 8.5 inches (182 to 216 mm)
Length	Paper guide: 3.9 to 14.3 inches (100 to 364 mm) Cut-sheet feeder: 10.1 to 14.0 inches (257 to 356 mm)
Thickness	Paper guide: 0.0025 to 0.0055 inch (0.065 to 0.14 mm) Cut-sheet feeder: 0.0028 to 0.0055 inch (0.07 to 0.14 mm)
Weight	Paper guide: 14 to 24 lb (52 to 90 g/m <sup>2</sup> ) Cut sheet feeder: 18 to 24 lb (64 to 90 g/m <sup>2</sup> )

**Single-sheet multipart forms: paper guide entry**

Width	3.9 to 10.1 inches (100 to 257 mm)
Length	3.9 to 14.3 inches (100 to 364 mm)
Copies	1 original + up to 4 copies
Thickness	0.0047 to 0.015 inch (0.12 to 0.39 mm)
Weight	12 to 15 lb (40 to 58 g/m <sup>2</sup> )
Binding	Line-glued at the top or one side of form

**Envelopes: paper guide entry**

Size	No. 6: 6.5 × 3.6 inches (165 × 92 mm) No. 10: 9.5 × 4.1 inches (241 × 105 mm)
Thickness	0.0063 to 0.0205 inch (0.16 to 0.52 mm)
Weight	12 to 24 lb (45 to 90 g/m <sup>2</sup> )

**Continuous paper (standard and multipart):  
rear and bottom entry**

Width	4.0 to 10.0 inches (101.6 to 254 mm)
Length (one page)	4.0 to 22.0 inches (101.6 to 558.8 mm)
Copies	1 original + up to 4 copies
Thickness	0.0025 to 0.015 inch (0.065 to 0.39 mm)  Gathering area up to 0.035 inch (0.9 mm)
Weight (not multipart)	14 to 22 lb (52 to 82 g/m <sup>2</sup> )
Weight (one sheet of multipart)	12 to 15 lb (40 to 58 g/m <sup>2</sup> )
Binding	Spot glued or crimp bound on both sides

**Labels: bottom entry**

Label size	15/16 × 2.5 inches (23.8 × 63.5 mm) minimum 0.1 inch (2.5 mm) corner radius, minimum
Backing sheet width	4.0 to 10.0 inches (101.6 to 254 mm)
Backing sheet length	4.0 to 22.0 inches (101.6 to 558.8 mm)
Backing sheet thickness	0.0028 to 0.0035 inch (0.07 to 0.09 mm)
Total thickness	0.0063 to 0.0075 inch (0.16 to 0.19 mm)
Label weight	17 lb (64 g/m <sup>2</sup> )

**Roll paper: rear entry with optional roll paper holder**

Width	8.5 inches (216 mm)
Thickness	0.0028 to 0.0035 inch (0.07 to 0.09 mm)
Weight	14 to 22 lb (52 to 82 g/m <sup>2</sup> )

## Printable area

### Single sheets and envelopes:

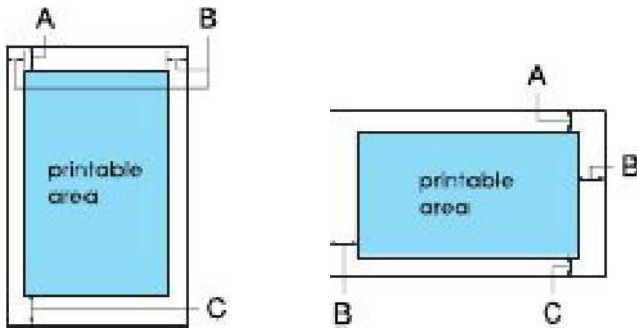

- A The minimum top margin is 0.17 inch (4.2 mm).
- B The minimum left and right margins are 0.12 inch (3.0 mm).  
For single sheets the maximum paper width is 10.1 inches (257 mm).  
The maximum printable width is 8.0 inches (203.2 mm).  
If the paper size is substantially wider than this, the side margins will be wider than the minimum, but the printable width does not increase beyond 8.0 inches (203.2 mm).
- C The minimum bottom margin is 0.17 inch (4.2 mm).

## Continuous paper

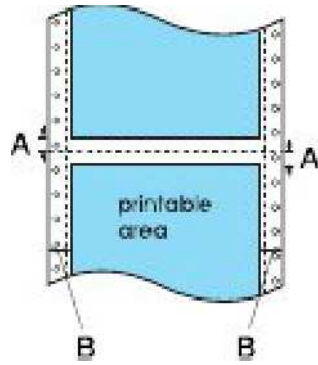

- A The minimum top and bottom margins above and below the perforation are 0.17 inch (4.2 mm) each.
- B The minimum left and right margins are 0.51 inch (13 mm) each.

The maximum paper width is 10.0 inches (254 mm).

The maximum printable width is 8.0 inches (203.2 mm). If the paper size is substantially wider than this, the side margins will be wider than the minimum, but the printable width does not increase beyond 8.0 inches (203.2 mm).



## Roll paper:

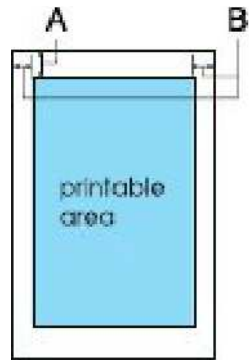

- A The minimum top margin is 0.17 inch (4.2 mm).
- B The minimum left margin is 0.12 inch (3.0 mm).  
The minimum right margin is 0.12 inch (3.0 mm).  
The maximum printable width is 8.0 inches (203.2 mm).

## Paper alignment

Printing starts at "0" on the scale. The unprintable area is to the left of the "0."

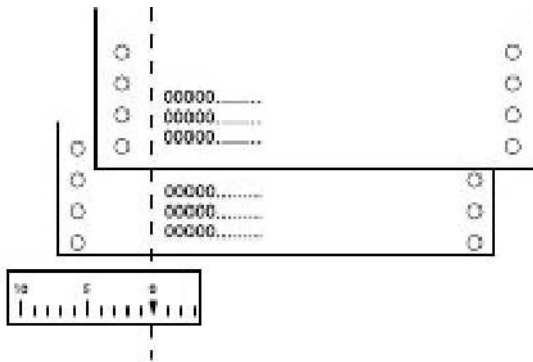

---

## Command Lists

Your printer supports the Epson ESC/P control codes and IBM 2380 Plus emulation control codes listed below.

### **EPSON ESC/P control codes**

Selecting an Epson ESC/P printer in your software allows you to use advanced fonts and graphics.

General operation:

ESC @, ESC U, ESC EM

Paper feeding:

FF, LF, ESC 0, ESC 1, ESC 2, ESC 3, ESC A, CR

Page format:

ESC (C, ESC C, ESC C 0, ESC Q, ESC l, ESC (c, ESC N, ESC O,  
ESC (U

Print position motion:

ESC \$, ESC \, ESC D, HT, ESC B, VT, ESC J

Font selection:

ESC k, ESC x, ESC y, ESC P, ESC M, ESC g, ESC p, ESC 4, ESC 5,  
ESC E, ESC F, ESC !

Font enhancement:

ESC W, DC4, SO, DC2, SI, ESC w, ESC G, ESC H, ESC T, ESC S,  
ESC -

Spacing:

ESC Space

Character handling:

ESC t, ESC (t, ESC R, ESC %, ESC &, ESC :, ESC I, ESC 6,  
ESC 7

Bit image:

ESC K, ESC L, ESC Y, ESC Z, ESC \*, ESC ^

Bar code:

ESC (B

## ***IBM 2380 Plus emulation control codes***

This printer emulates the IBM Proprinter using the commands below. For detailed information, see the IBM 2380 Plus reference manual.

General operation:

NUL, DC3, ESC j, BEL, CAN, DC1, ESC Q, ESC [ K, ESC U,  
ESC [ F

Paper feeding:

FF, LF, ESC 5, ESC A, ESC 0, ESC 1, ESC 2, ESC 3, CR, ESC ]

Page format:

ESC C, ESC C0, ESC X, ESC N, ESC O, ESC 4

Print position motion:

ESC d, ESC R, ESC D, HT, ESC B, VT, ESC J

Font selection:

DC2, ESC P, ESC :, ESC E, ESC F, ESC I, ESC [d, ESC [I

Font enhancement:

DC4, SO, ESC SO, ESC W, ESC [ @, SI, ESC SI, ESC G, ESC H,  
ESC T, ESC S, ESC -, ESC \_

Spacing:

BS, SP

Character handling:

ESC 6, ESC 7, ESC [T, ESC ^, ESC \

Bit image:

ESC K, ESC L, ESC Y, ESC Z

Bar code:

ESC [f, ESC [p

Download:

ESC = (only Draft mode)

---

## **Standards and approvals**

### **Safety approvals**

120 V version:

Safety standards	UL60950 CSA60950
EMI	FCC part 15 subpart B Class B CAN/CSA - CEI/IEC CISPR22 class B

230 V version:

Safety standards	EN60950
EMI	AS/NZS CISPR22 class B
EMC	EN55022 class B EN61000-3-2 EN61000-3-3 EN55024

### **CE marking**

230 V version:

Low Voltage Directive 73/23/EEC	EN60950
EMC Directive 89/336/EEC	EN55022 class B EN61000-3-2 EN61000-3-3 EN55024

---

# Index

## A

Accessing printer driver, 34 to 37  
Accessories, 97  
Accoustic noise, 112  
Additional tractor, 98, 102 to 103, 112  
Adjusting  
  paper thickness lever, 29 to 30  
  tear-off position, 25 to 26  
  top-of-form position, 22 to 23  
Auto  
  CR, 68, 72  
  I/F wait time, 67, 70  
  line feed, 67, 69  
  tear-off, 14, 24, 67, 69

## B

Baud rate, 67, 70  
Bidirectional  
  mode, 67, 71  
  printing, 69  
Built-in fonts, 65 to 66, 113 to 114  
Buttons, control panel, 63 to 66  
Buzzer, 68, 72

## C

Canceling printing, 58 to 59  
Changing  
  default settings, 67 to 73  
  printer driver settings, 38 to 39  
Character  
  sets, international, 114  
  table, 68, 71, 114  
Cleaning printer, 74 to 75  
Clearing paper jam, 93 to 94  
Client computers, 49 to 56

Continuous paper  
  loading, 11 to 14, 19 to 21  
  printing on, 11 to 26  
  specifications, 117  
Control codes, 122 to 124  
Control panel, 109  
  buttons, 63 to 66  
  lights, 63 to 66, 77 to 78  
  using, 63 to 73  
Custom paper size, 40  
Cut-sheet feeder, 88, 98 to 101, 112

## D

Data length, 67, 71  
Default Setting mode, 67 to 73  
Default settings  
  changing, 67 to 73  
  restoring, 73

## E

Edge guides, 109  
Electronic specifications, 113 to 114  
Envelopes, 29 to 30, 32, 117  
Environmental specifications, 115  
EPSON, help, 96 to 97  
EPSON Status Monitor 3, 33, 41 to 44,  
  59 to 61  
Error lights, 77 to 78  
ESC/P, 33, 122 to 124

## F

Feeding method, 112  
Fonts, built-in, 65 to 66, 113 to 114

## **H**

Help, EPSON, 96 to 97  
High speed draft, 67, 70  
Hot parts caution symbol, 7

## **I**

I/F mode, 67, 70  
IBM character table, 68, 72  
Interface setting, 67, 70  
International character set, 68, 71, 114  
Internet technical support, 96

## **L**

Labels, 29 to 32, 118  
Lights, control panel, 63 to 66, 77 to 78  
Line spacing, 111  
Loading paper  
  envelopes, 29 to 30, 32  
  labels, 29 to 32  
  multipart forms, 29 to 31  
  on the pull tractor, 19 to 21  
  on the push tractor, 11 to 14  
  single sheets, 26 to 28

## **M**

Manual feed wait time, 68, 71  
Micro Adjust mode, 22 to 23, 64 to 65  
Multipart forms, 29 to 31, 116

## **N**

Network, 45 to 58

## **O**

Options  
  problems, 87 to 89  
  purchasing, 97  
  using, 98 to 108

## **P**

Packet mode, 67, 71  
Page length for tractor, 67 to 68, 84  
Paper  
  feed knob, 109  
  feed speed, 112  
  guide, 14, 109  
  handling, 11 to 32  
  jam, clearing, 93 to 94  
  loading, 11 to 32  
  loading on the pull tractor, 19 to 21  
  loading on the push tractor, 11 to 14  
  problems, 84 to 87  
  release lever, 12, 17, 27, 109  
  single sheets, 26 to 28  
  specifications, 115 to 121  
  supports, 109  
  tension unit, 17, 110  
  thickness lever, 29 to 30, 110  
Parallel  
  I/F mode, 67, 71  
  interface, 67, 70, 110  
Parity, 67, 70  
Power cord, 110  
Power supply problems, 79 to 80  
Printable columns, 111  
Print direction, 67, 69  
Printer  
  cleaning, 74 to 75  
  cover, 109  
  parts, 109 to 110  
  server, 45 to 49  
  sharing, 45 to 58  
  specifications, 111 to 124  
  transporting, 75 to 76  
Printer driver  
  accessing, 34 to 37  
  settings, 38 to 39  
Printer software  
  uninstalling, 59 to 61  
  using, 33 to 58

- Printing
    - canceling, 58 to 59
    - envelopes, 29 to 30, 32
    - labels, 29 to 32
    - multipart forms, 29 to 31
    - on continuous paper, 11 to 26
    - on single sheets, 26 to 28
    - on special paper, 29 to 32
    - problems, 80 to 84
    - self test, 94 to 95
  - Problems
    - options, 87 to 89
    - paper handling, 84 to 87
    - power supply, 79 to 80
    - printing, 80 to 84
    - solving, 76 to 95
    - USB, 90 to 93
  - Pull tractor
    - additional, 98, 102 to 103, 112
    - installing, 18
    - printing with, 11, 17 to 21
  - Push tractor
    - printing with, 11 to 16
    - removing, 17 to 18
- R**
- Resolution, 111
  - Restoring default settings, 73
  - Ribbon cartridge
    - life, 112
    - location, 110
    - replacing, 82, 98, 105 to 108
  - Roll paper holder, 98, 104 to 105, 112
  - Roll paper specifications, 118
- S**
- Safety instructions, 7 to 10
  - Self test, 94 to 95
  - Serial interface, 67, 70, 110
  - Server, printer, 45 to 49
  - Sharing printer, 45 to 58
  - Single-bin cut-sheet feeder, 98 to 101, 112
  - Single sheets
    - loading, 26 to 28
    - printing, 26 to 28
    - specifications, 116
    - switching to, 16
  - Skip over perforation, 67 to 68, 84
  - Software setting, 67, 69
  - Special paper, printing on, 29 to 32
  - Specifications
    - control codes, 122 to 124
    - electrical, 115
    - electronic, 113 to 114
    - environmental, 115
    - mechanical, 111 to 112
    - paper, 115 to 121
    - printer, 111 to 124
    - standards and approvals, 125
  - Status Monitor 3, 33, 41 to 44, 59 to 61
  - Support, technical, 96 to 97
  - Switching paper source, 16
- T**
- Tear-off
    - button, 23 to 25
    - edge, 15, 23 to 26
    - position, 23 to 26, 63 to 64
  - Technical support, 96 to 97
  - Thick paper, printing on, 29 to 30
  - Top-of-form position, 22 to 23, 64
  - Tractor, 11 to 16
    - installing, 18
    - location, 110
    - optional, 98, 102 to 103
    - pull, 17 to 21
    - removing, 17 to 18
  - Transporting printer, 75 to 76
  - Troubleshooting, 76 to 95



## **U**

Unidirectional (Uni-d) printing, 69

Uninstalling

printer software, 59 to 61

USB device driver, 61 to 62

USB

cable, 93

cable holder, 110

device driver, uninstalling, 61 to 62

interface, 67, 70, 110

problems, 90 to 93

## **Z**

Zero slash, 67, 69