

Adjustments

HP DeskJet 6xx Printers

Checking the Paper Guide-To-Pivot Gap

1. Center the carriage between the right and center drive rollers.

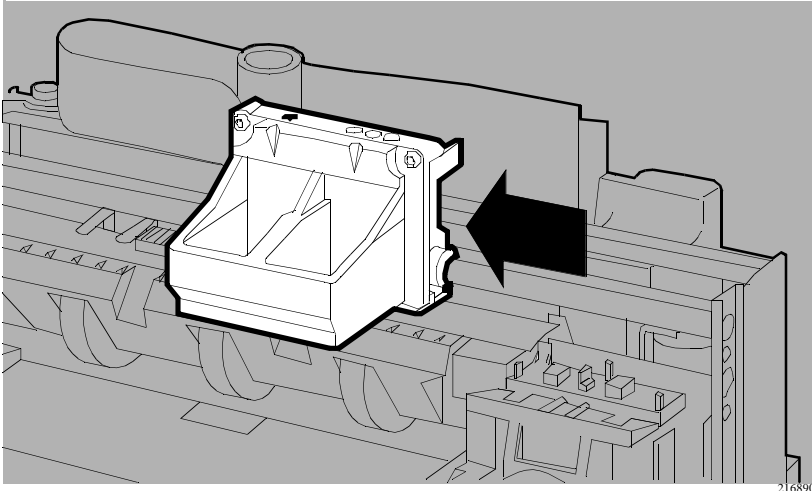

2. If removed, install the PPS Measure Tool. Snap the PPS Measure Tool into the cradle, just like installing a print cartridge.

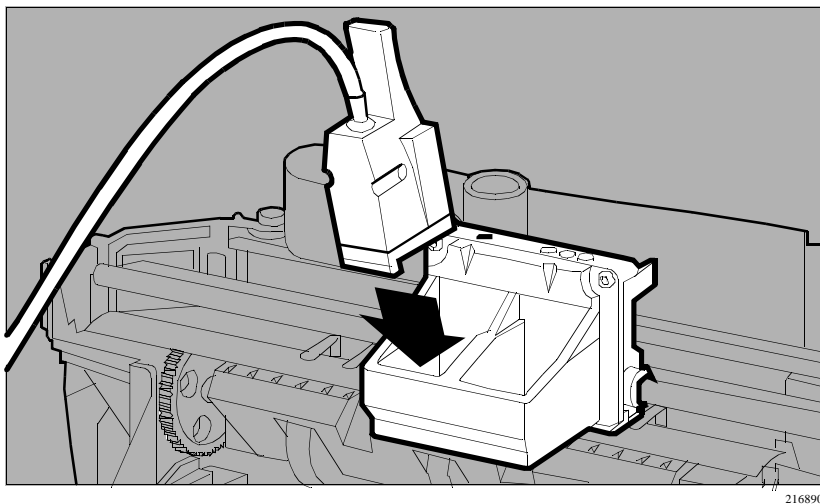

3. Lift the envelope sensor on the mechanism to raise the pivot to its maximum height.

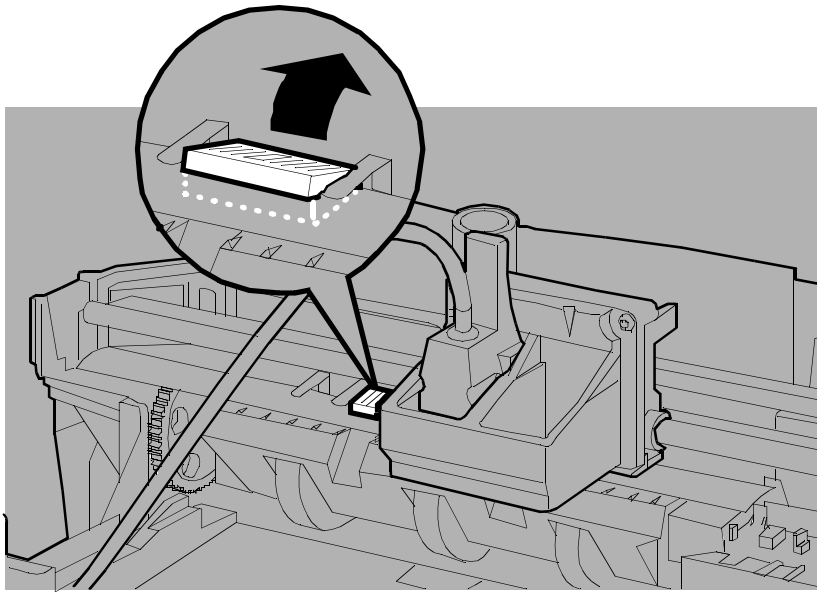

2168907

4. Observe the Readout/Controller reading with no shim on the paper guide.
5. Push down on the pivot, dropping the envelope sensor down onto the paper guide.
6. Place the adjustment shim on the pivot pad, located at the far right end of the pivot.

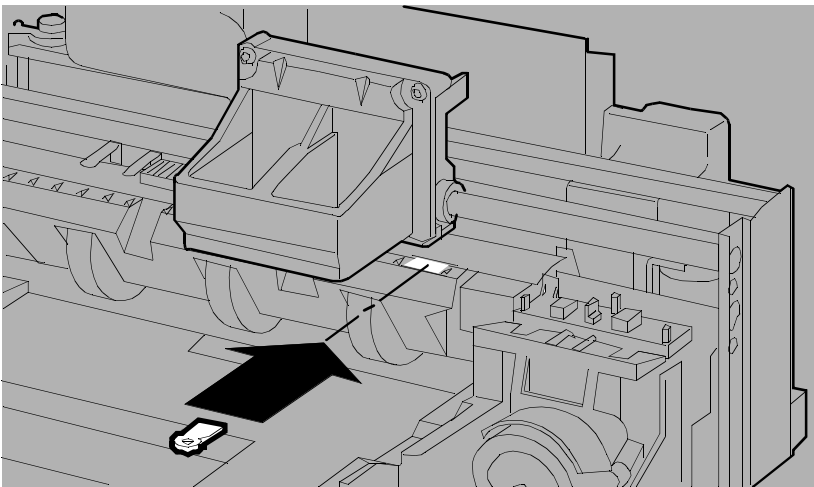

2168905

7. Lift the envelope sensor on the mechanism to raise the pivot to its maximum height. This will allow the pivot to release and capture the shim against the paper guide.

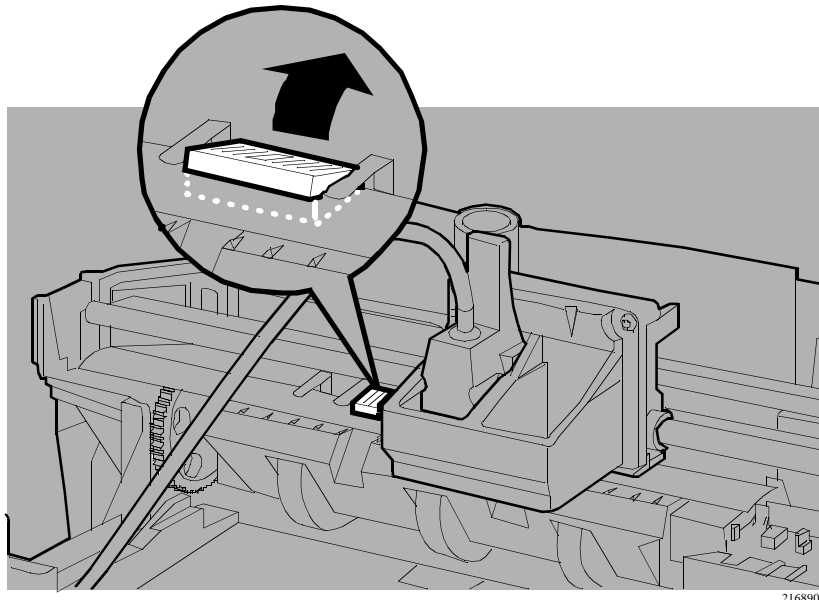

8. Observe the Readout/Controller reading with the shim in place.
9. Determine the difference between the reading with the adjustment shim installed and removed from the mechanism. The difference between the readings should be between **015.00 and 035.00 mils**.
 - If the Readout/Controller readings are within 015.00 and 035.00 mils of each other, remove the adjustment shim check the wiper height.
 - If a Readout/Controller reading is not within 015.00 and 035.00 mils of each other, the mechanism requires the paper guide-to-pivot gap adjustment. Remove the adjustment shim and adjust the paper guide-to-pivot gap.

